

#8 High Power Socket Contact

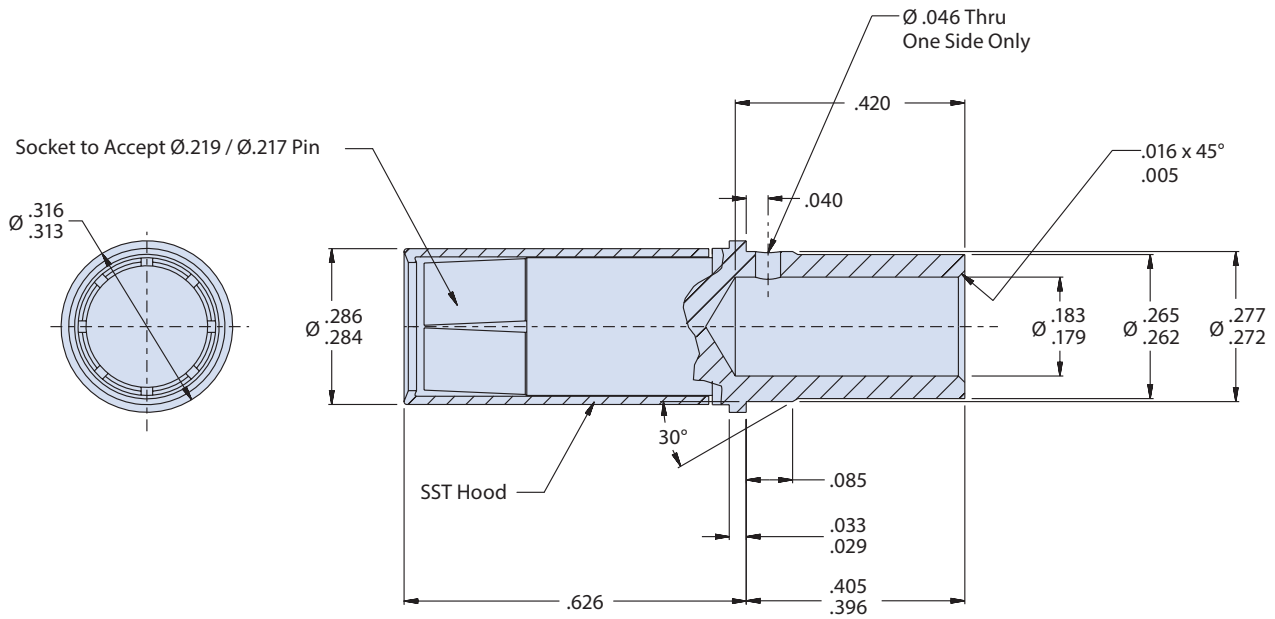

Mating End Size	Wire Accommodation	Glenair Part Number
8	8 AWG	850-013



D

Material and Finish

Contact Body: Copper alloy, plated with 50 microinches gold per ASTM B488 Type II code C over 50–100 microinches nickel IAW SAE AMS-QQ-N-290, class II
 Hood: CRES, passivated

Crimp Tools and Insertion/Extraction Tools

Crimp Tool: 859-025 (M22520/23-01)
 Crimp Die: 859-026 (M22520/23-02)
 Locator: 859-046 (Daniels WA23-395L)
 or Spring Locator (recommended): 859-164 (Daniels WA23-395SLL)
 Consult factory for cable accommodation and respective tool compatibility.

Notes

For use with MM, SuperNine (233-217 and 233-218).