

## ASSEMBLY INSTRUCTIONS 460-1

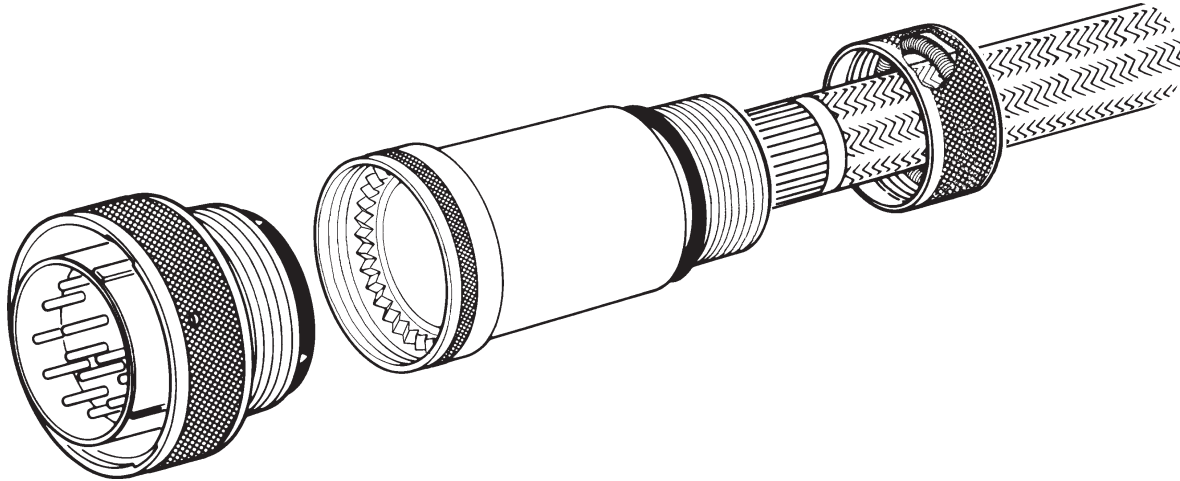

The following suggested procedure serves as a guide for the proper assembly and installation of Glenair EMI/RFI Non-Environmental Backshells (Type 460 G-spring Termination). It is recommended that trial samples of appropriate cables or harnesses be used to determine proper trim dimensions of the outer shield and individual conductors.

- a. Temporarily assemble backshell to connector.
- b. Place backshell, support ring (if used), G-Spring, nut or strain relief on cable or harness in sequence shown. Keep these components at a convenient distance from the end of the cable, so they will not interfere with subsequent assembly steps.
- c. Insert cable or harness into backshell and bottom against connector. Hold cable in position and mark outer shield at rear end of backshell.
- d. Remove backshell from connector and place on cable with items in step (b) above.
- e. Trim outer shield at mark made in step (c) above.
- f. Prepare and terminate contacts to individual conductors in accordance with established practices. (Crimp or solder in place.)
- g. Slide backshell forward to connector, and tighten securely.
- h. Move support ring (optional component used over loose wire bundles) forward, ahead of the trimmed outer shield, then slide support ring backward under outer shield. Pull outer shield forward covering support ring.
- i. Bring G-spring forward, and position on outer shield directly over the support at the rear of the backshell. Push G-spring and support ring into beveled area of backshell.
- j. Engage strain relief to backshell and tighten securely. Tighten relief saddles securely on cable or harness. This will then provide a good grounding or bonding joint for the over-all shields.

NOTE: As with any electrical connector assembly procedure, be sure to use the proper tools. For convenient, reliable assembly of the connector and backshell, it is suggested that Glenair's connector holding tools, strap wrenches and connector pliers be used.