

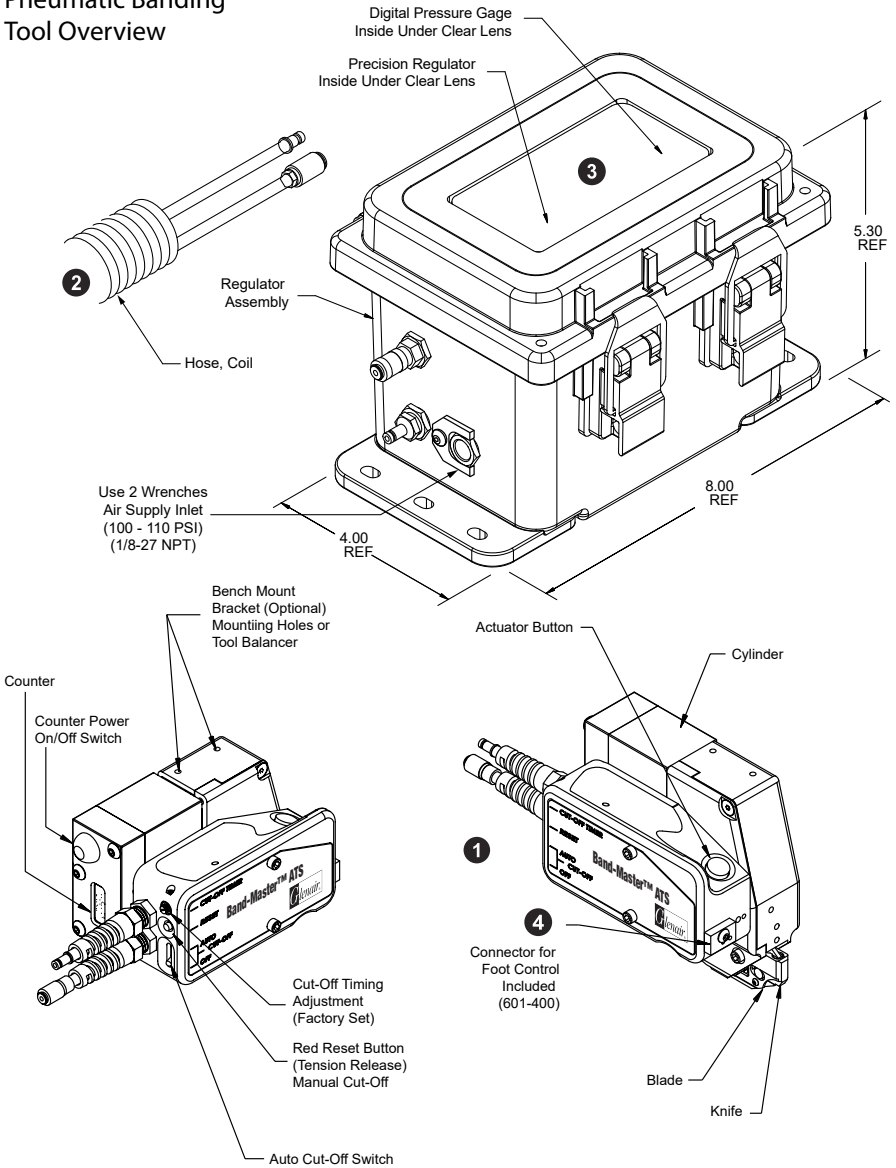


# **Band-Master® ATS Pneumatic Banding Tools 601-106 and 601-107 Operating Instructions**



# Figure 1

## Band-Master™ ATS Pneumatic Banding Tool Overview



# Band-Master ATS®

## The Advanced Termination System for Interconnect Cable Shielding

### **GLENAIR 601-106 STANDARD PNEUMATIC TOOL WITH COUNTER**

For use with Band-Master® ATS bands P/N 601-005, 601-006, 600-052 and 600-052-1

#### **SPECIFICATIONS:**

Tension Range . . . . .	100-180 lbs Adjustment Range. Calibrate at 150 ±5 lbs
<b>Weight</b>	
Tool Head . . . . .	2.52 lbs
Control Box . . . . .	3.51 lbs

#### **601-106 Kit Contains The Following Additional Items (see fig. 1):**

1. 601-106-1 Tool Head, Pneumatic
2. 601-310 Hose, coil
3. 601-311 Regulator Assembly
4. 601-400 Foot Control/Bench Mount Kit

### **GLENAIR 601-107 MICRO PNEUMATIC TOOL WITH COUNTER**

For use with Band-Master® ATS bands P/N 601-024, 601-025, 600-057 and 600-057-1

#### **SPECIFICATIONS:**

Tension Range . . . . .	60-90 lbs Adjustment Range. Calibrate at 80 ±5 lbs
<b>Weight</b>	
Tool Head . . . . .	2.52 lbs
Control Box . . . . .	3.51 lbs

#### **601-107 Kit Contains The Following Additional Items (see fig 1):**

1. 601-107-1 Tool Head, Pneumatic
2. 601-310 Hose, coil
3. 601-311 Regulator Assembly
4. 601-400 Foot Control/Bench Mount Kit

## **CONTENTS**

<b>Safety</b> .....	5
<b>Initial Tool Set-up</b> .....	5
Regulator assembly bench top mounting hole pattern.....	5
Band-Master® assembly instructions for 601-106 and 601-107 tool heads to 601-311 regulator.....	6
Band-Master® ATS operating instructions.....	7
Counter features.....	8
<b>Maintenance</b> .....	9
Drain water accumulation from filter assembly.....	9
Clean/replace filter element.....	9
Adjust cut-off timer.....	9
Replace worn/damaged cutter knife or blade.....	9
Counter battery replacement.....	11
<b>601-106 and 601-107 Band Inspection</b> .....	11
<b>601-106 Replacement Parts for Standard Pneumatic tool with Counter</b> .....	13
<b>601-107 Replacement Parts for Micro Pneumatic Tool with Counter</b> .....	13
<b>Bands and Accessories</b> .....	14
Replacement bands.....	14
Tool balancer (sold separately).....	14
Foot control/bench mount kit.....	14

## **SAFETY**

- Never use power tools or clamps for anything other than their intended purpose, if in doubt consult factory
- Keep hands away from clamps being tensioned
- Always wear safety glasses when operating power tool

## **INITIAL TOOL SET-UP**

All Band-Master® ATS pneumatic tools with counter operate on compressed air. Connect air supply to regulator assembly using a quick-disconnect socket 1/4" body. This connection is recommended so tool can be moved to another location or disconnected from air supply when not in use. Supply pressure to regulator assembly must be between 100-110 PSI. Higher pressure could damage internal components. Lower pressure slows tool down and makes cutting of band uncertain. 40 micron pre-filtering element is recommended on contaminated supply lines.

An air dryer is recommended on supply lines with water accumulation problems. No lubricator is used on the tool. Introducing oil to air system will do more harm than good.

All tools are factory set for nominal clamping conditions. Tension is set by adjusting pressure on regulator assembly.

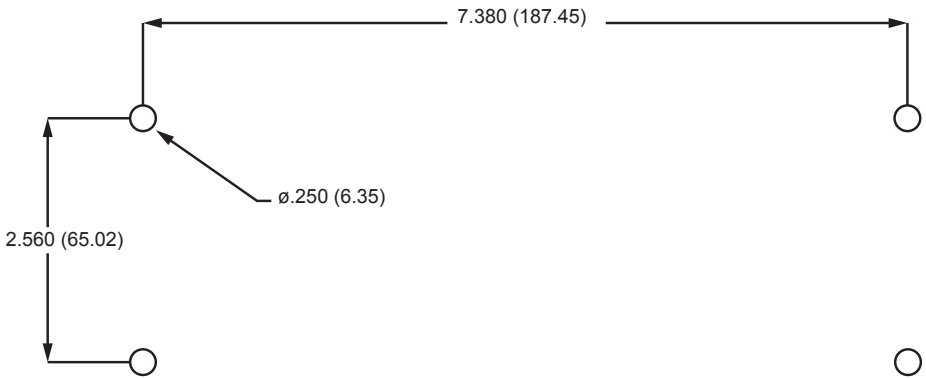
**CAUTION:** Under-tensioned clamps result in loose assemblies. Excessive tension may damage clamp, backshell or band tool mechanism

### **Regulator assembly bench top mounting**

In a permanent installation, regulator assembly should be bolted to a flat surface to allow flexible cord to be stretched without dragging regulator assembly (see Fig. 2 for mounting pattern). Keep filter vertical to maximize the water and contaminant capacity.

**Figure 2**

Bench Top Mounting Hole Pattern (for controller box bracket)

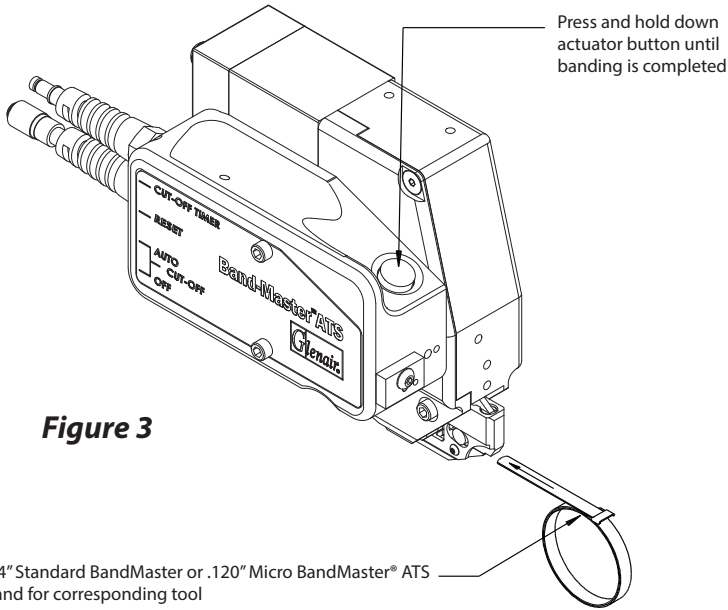


**Band-Master® assembly instructions for 601-106/601-107 tool heads to 601-311 regulator**

1. Assemble tool and regulator using coil hose.
2. Adjust pressure by opening cover, loosen the 5/16 hex nut slightly under the adjustment knob.
3. Touch ON/OFF button on the digital gage to turn on readout. Readout will auto shutoff after 20 minutes

**NOTE:** Pressure is factory set, adjust only if necessary. Pressures are for reference only, exact values change from tool to tool.

4. Adjust the regulator while reading the digital pressure gage to achieve the correct psi, resulting in the pull required for each type of band:
  - Standard tool 1/4 inch band, 44 psi, 150 pound pull.
  - Micro tool 1/8 inch band, 23 psi, 80 pound pull.
 See pages 11 and 12 for additional pressure adjustment information
5. The digital gauge on the top of the regulator assembly **MUST** indicate the proper pressure for the type of tool and band used.
6. Lock the adjustment shaft by tightening the 5/16 nut under the adjustment knob. **Do not overtighten the adjustment locking nut.**



**Figure 3**

.24" Standard BandMaster or .120" Micro BandMaster® ATS band for corresponding tool

## **Band-Master® ATS Operating Instructions**

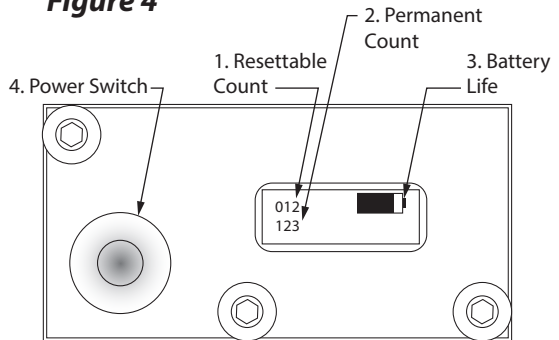
1. Insert band tail through the tool nose opening (see Fig. 3), making sure that clamp circle is directed away from the tool body.
2. To tension the band, press and hold down actuator button. Always install bands perpendicular to the axis of the object to be clamped. Do not force tool sideways or in any other direction when band tail is under tension or during cut-off. Doing so may damage clamp and/or tool.
3. The Band-Master® ATS pneumatic tool with counter will automatically cut the band once the desired tension has been reached. If no cut-off occurs, check to make sure the automatic cut-off switch has been turned "on" (the silver switch on the back side of the handle should point toward the red reset button). If the switch is pointing in the wrong direction, flip it to the "auto" position and the tool will cut off the band. If cut-off stalls, turn switch off and immediately on again while holding down actuator button. This may have to be done only once with the first band, after tool has been pressurized.
4. Immediately after cut-off, release actuator button and remove the excess band from the tool.

## Counter features

(see figure 4)

1. Resettable usage count (top number)
2. Permanent count (bottom number)
3. Battery life
4. Power switch

**Figure 4**



## Important notes:

- Air supply line pressure is critical. 100-110 psi is required at the inlet port of the regulator assembly to allow the tool to operate properly. For line pressures less than 100 psi the tool must be tested for proper operation.
- **DO NOT ADJUST THE REGULATOR ON THE REGULATOR ASSEMBLY OVER 100 PSI**
- Do not over tighten the 5/16 inch hex locking collar for the regulator shaft, damage may occur.
- Improperly installed clamps may result in faulty shield termination and insufficient ground bonding.
- Do not twist or force tool or cable assembly in any direction while installing clamps.
- Always install clamps perpendicular to the axis of the cable being terminated. When clamping irregular shaped band platforms, choose a location of the buckle where it is well supported on the bottom. A properly designed backshell with a lip are essential when tensile loads may be expected.
- To verify tension setting after the tool has been at rest for some time, actuate the tool momentarily and confirm pressure setting on the digital pressure gauge.



- Glenair recommends that banding occur on an unfixtured cable assembly. Trying to band on a firmly fixed surface may affect the applied forces and interfere with the cut-off operation. The cut-off operation causes a rotation of the band termination in order to affect a lock. Therefore, when performing the banding operation on a fixtured cable or device the operator **MUST** allow the band tool to rotate slightly as the cut-off operation is performed.

## MAINTENANCE

### Drain water accumulation from filter assembly: (See Fig. 4)

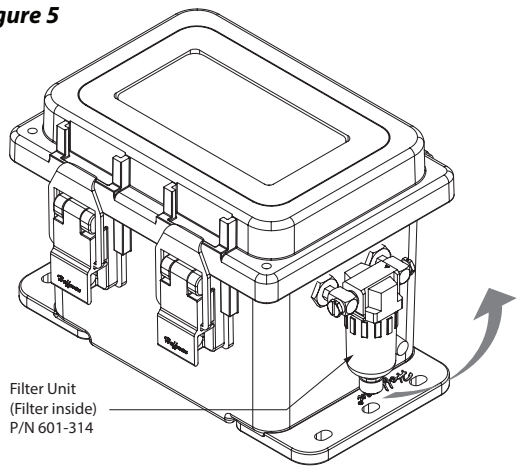
1. Disconnect air pressure.
2. Holding bottom of filter rotate filter housing up, away from regulator body and place a small cup under the filter.
3. Push in the valve at the base of the filter to drain water:

### Clean/replace filter element:

(See Fig. 5)

1. Disconnect air supply
2. Holding bottom of filter rotate filter housing up, away from regulator body and unscrew clear plastic housing.
3. Unscrew filter element and clean/replace gold colored element.
4. Replacement (if necessary) must be a 5 micron filtering element, available from Glenair (part number 601-314)

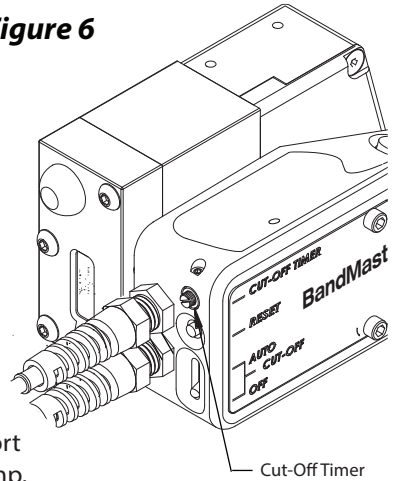
**Figure 5**



## Adjust cut-off timer (See Fig. 6)

1. Do not alter factory setting, unless necessary.
2. A small copper screw found on the back of the tool handle (above the reset button) adjusts the cut-off timing.
3. Using a small, standard screwdriver, turn the screw clockwise to increase the cut-off delay, and counter-clockwise to decrease the cut-off delay.

**Figure 6**



**Caution:** Adjusting cut-off delay timing too short will result in premature cut-off, and a loose clamp.

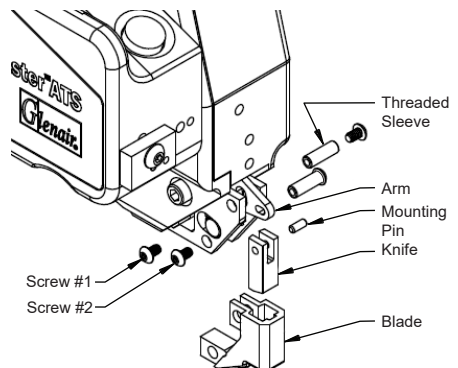
**Note:** Normal delay is between 1 and 2 seconds after shuttle stops cycling.

## Replace worn/damaged cutter knife or blade (See Fig 7)

This procedure is easier to do if tool is connected to air supply.

1. Remove two button head cap screws (BHCS) with 1/16 hex keys. Two hex keys will be needed to complete this step.
2. Push out two BHCS screws and threaded sleeve nuts using one of the 1/16 hex keys, then remove cutoff knife by pushing mounting pin out.
3. When BHCS/threaded sleeves are removed, lift cutoff blade out of tool head.
4. Assemble in reverse order
5. If needed loctite, low strength, 222, purple, can be applied to BHCS screw.
6. Torque BHCS to 2-3 in/lbs.  
**Important:** To order correct replacement parts, locate tool model number on tool head.

**Figure 7**



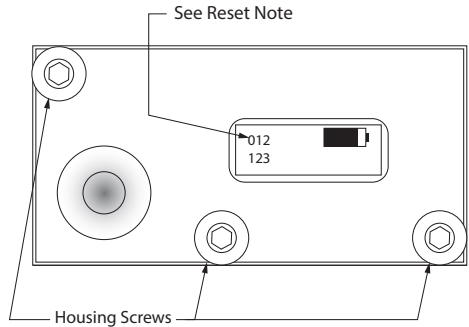
Replacement part numbers for each tool can be found on page 13.

**Figure 8**

## Counter Battery Replacement

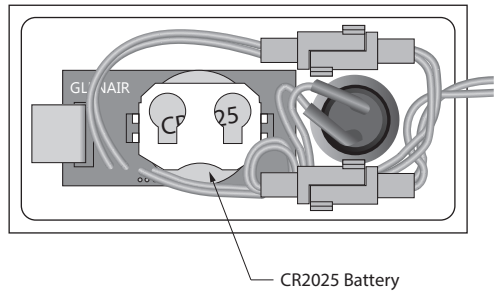
(see figure 8)

1. Remove 3, SHCS screws from counter cover with 9/64 hex key.
2. Gently lift cover and counter assembly away from side of tool (do not pull wires)
3. With cover off, remove two screws and washers
4. Pull up board, remove and insert new 2025 (or equivalent) battery with (+) sign facing up (opposite to screen display)



## Counter Reset

1. Remove housing
2. Remove and replace battery to reset counter



# BANDING INSPECTION FOR 601-106 STANDARD AND 601-107 MICRO PNEUMATIC TOOLS

## Banding Inspection (See fig. 9)

1. Be sure to read regulator system instructions and important notes (page 8) before using tool.
2. **601-106 Standard Pneumatic Tool with Counter**  
Adjust regulator to a reading of 44 psi for a 150 pound pull. For accurate tension setting, Band-Master® ATS calibration device must be used (part no. 601-200). Pressure reading on gauge should be used for reference only. Same tension output may occur at somewhat different pressure readings from

tool to tool due to manufacturing tolerances. Calibration device will ensure proper tension setting. Tool is factory calibrated to 150 ±5 lbs tension.

### 601-107 Micro Pneumatic Tool with Counter

Adjust regulator to a reading of 23 psi for a 80 pound pull. For accurate tension setting, Band-Master® ATS calibration device must be used (part no. 601-200). Pressure reading on gauge should be used for reference only. Same tension output may occur at somewhat different pressure readings from tool to tool due to manufacturing tolerances. Calibration of device will ensure proper tension setting. Tool is factory calibrated to 80 ±5 lbs tension.

### 3. 601-106 Standard Pneumatic Tool with Counter

can only be used on .240" wide Band-Master® ATS bands.

**NOTE: .24" wide or wider bands can not be inserted into tool**

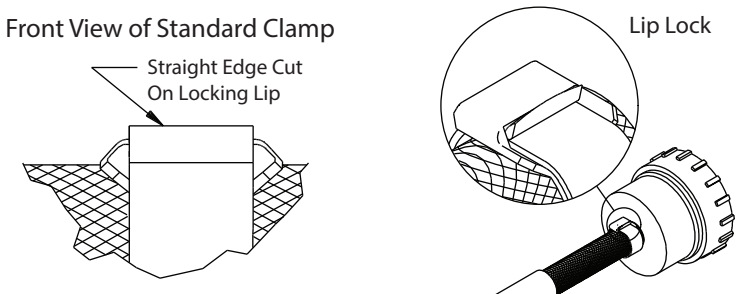
### 601-107 Standard Pneumatic Tool with Counter

can only use .120" wide Band-Master® ATS bands.

4. Condition of locking lip should be visually inspected on completed clamps. If lip appears partially torn, damaged or not present at all, check tool tension and condition of blade and knife. Make necessary adjustments and repairs. Be sure to remove and replace faulty clamps. If lip is damaged or missing, re-calibrate tool tension, check condition of cutter blade and knife, replace if worn or damaged.

**NOTE:** 1) If poor cutoff quality persists after knife and blade replacement, the tool must be serviced 2) Band can be removed by lifting buckle with a screwdriver or diagonal cutters.

**Figure 9**



## REPLACEMENT PARTS FOR 601-106 STANDARD PNEUMATIC TOOL WITH COUNTER

### Standard Pneumatic Replacement Parts

(only user replaceable parts are listed)

If *cutter blade* or *knife* is worn or damaged, replace with kit below.

Tool Part Number	Knife/Blade Kit Part Number
601-106	601-330

## REPLACEMENT PARTS FOR 601-107 MICRO PNEUMATIC TOOL WITH COUNTER

### Micro Pneumatic Replacement Parts (See fig. 10)

(Only user replaceable parts are listed)

If *cutter blade* or *knife* is worn or damaged, replace with kit below

Tool Part Number	Knife Part Number
601-107	601-329

## BANDS

Bands are available in short, medium or long and come flat or pre-coiled.

Bands	Band-Master® ATS Band Selection			
	Part Number		Fits Diameter	Length
	Flat	Pre-Coiled	In.(cm)	in./cm
Short Standard Band	601-005	601-006	1.0 (25.4)	9.0 (228.6)
Medium Standard Band	601-040	601-041	1.8 (45.7)	14.25 (361.95)
Long Standard Band	601-049	601-050	2.5 (63.5)	18.0 (457.2)
Short Micro Band	601-024	601-025	0.5 (12.7)	5.0 (127.0)
Medium Micro Band	601-060	601-061	.88 (22.4)	8.125 (206.38)
Long Micro Band	601-064	601-065	1.8 (45.7)	14.25 (361.95)

## ACCESSORIES

### Tool Balancer

Glenair tool balancer part number 601-401 is available for purchase. Contact factory for details and pricing

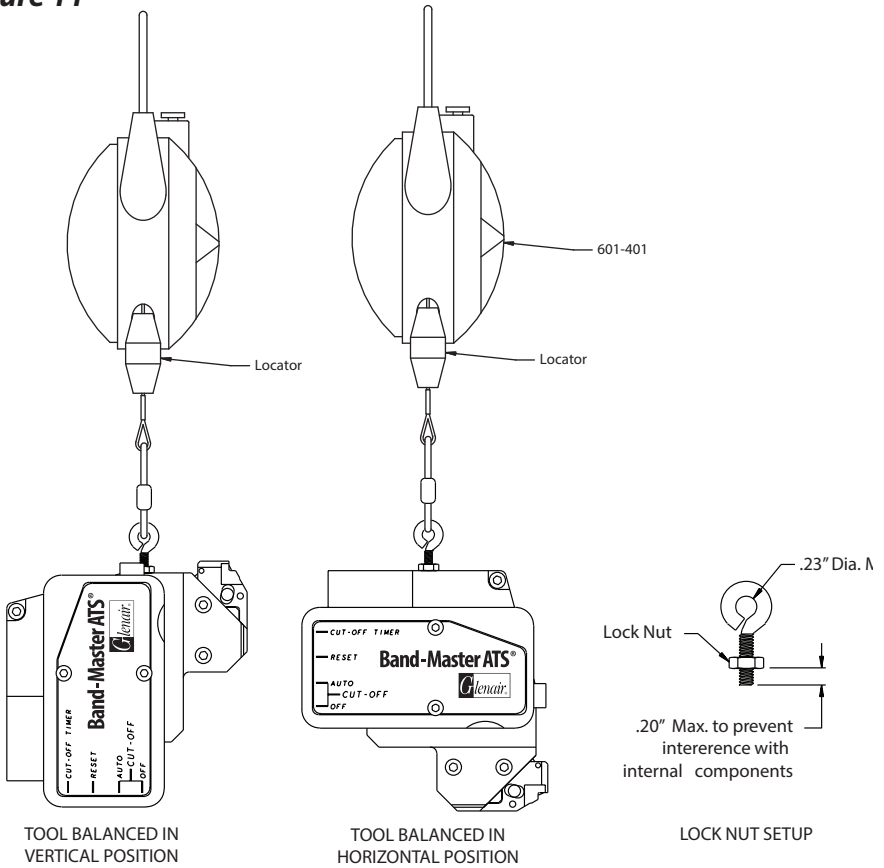
### Tool Balancer (See fig. 11)

1. If a tool balancer is desired, install tool balancer hook and set balancer to approximately 2.5 lbs balance weight
2. Balancer hook can be used with locator installed. Choose the most convenient mounting hole located on the tool body. **Be sure that lock nut is no more than .20" away from tip of thread to prevent interference with internal components**

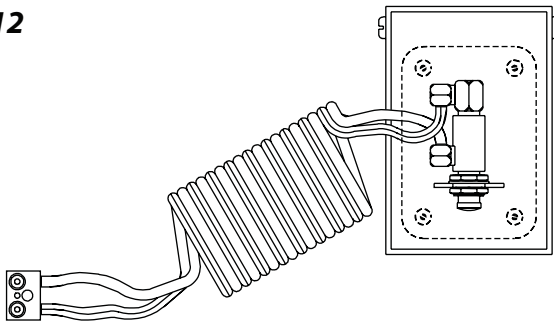
### 601-400 Foot Pedal Control (See fig. 12)

Every Pneumatic Band-Master® ATS, now includes foot pedal control, which frees both hands to help assure more accurate, reliable and faster shield terminations. For installation instructions see **Foot Control and Bench Mount Kit Installation** on page 18. See figure 13 for bench mounted configuration options.

**Figure 11**

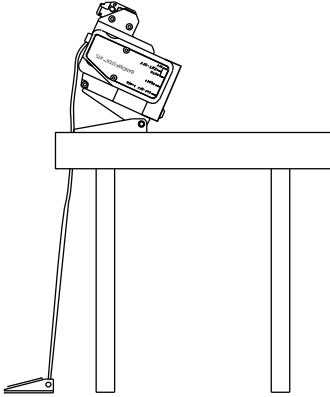


**Figure 12**



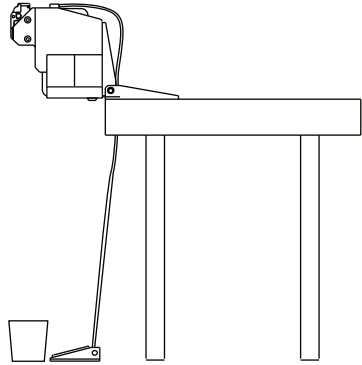
**Figure 13**

**TOP OF BENCH  
MOUNTED SET-UP CONFIGURATIONS**



Foot  
Control

Leave area behind tool  
free for excess band.

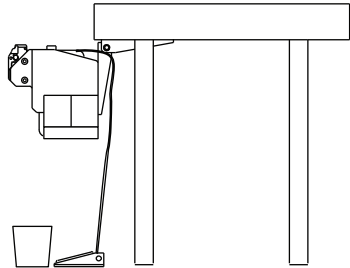


Place waste container  
under tool to collect excess band.

---

**UNDER BENCH  
MOUNTED SET-UP CONFIGURATION**

Bracket must be reversed for this set-up.  
If controller box is mounted to edge of work bench,  
this configuration will leave top of bench space free.  
Place waste container under tool to collect excess band.





### Foot Control and Bench Mount Kit Installation (601-400)

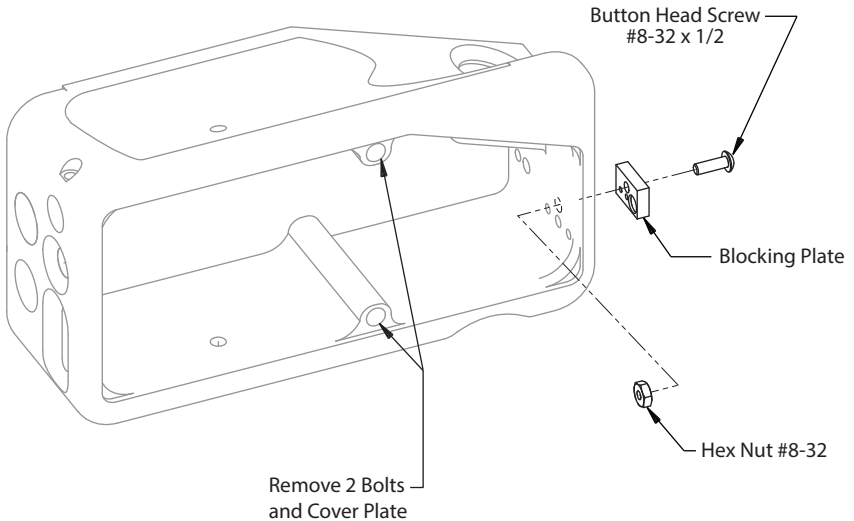
1. Disconnect tool from air supply and mount bracket to tool as shown.  
(See fig. 14B)
2. Remove air block from handle and store using second set of mounting holes.  
(See to fig. 14A and 14B)

See fig. 14B for steps 3 through 5)

3. Attach foot control connector using button head screw and #8-32 hex nut.  
Connect foot control pedal to connector
4. Mount bracket to top of tool using 2 socket head screws. Use smaller holes in bracket.
5. Mount other leg of bracket to bench using larger holes.
6. Adjust angle of tool to desired position and tighten bolt.

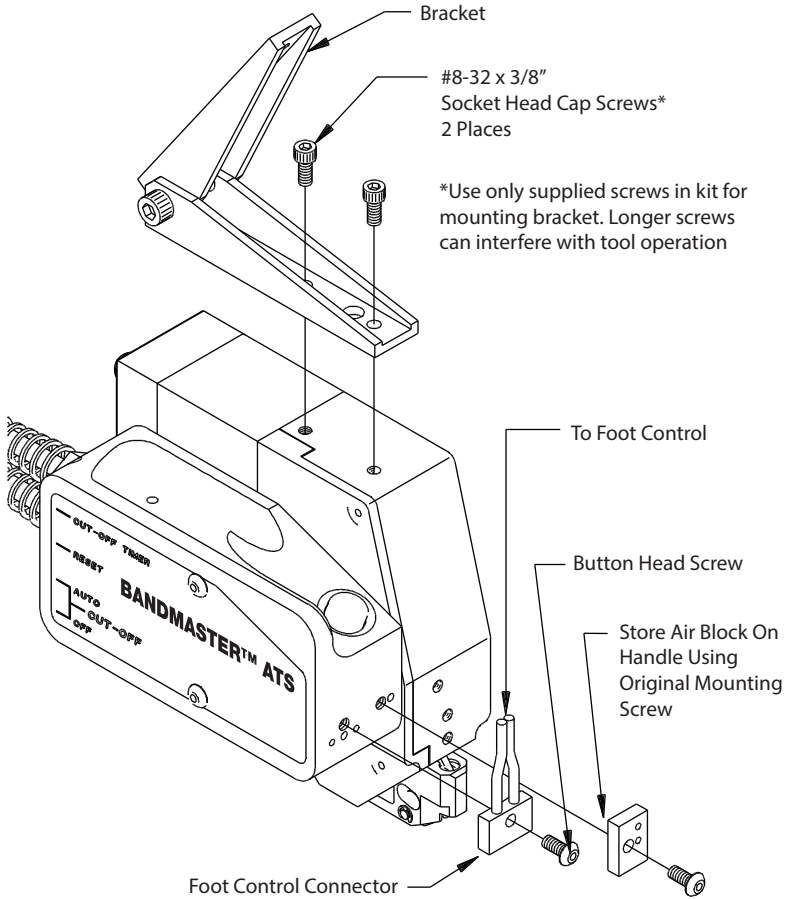
#### **Figure 14A**

Removal of Blocking Plate



### Figure 14B

Install Foot Control Connector and Bracket







1211 Air Way, Glendale, California 91201-2497  
818.247.6000

