

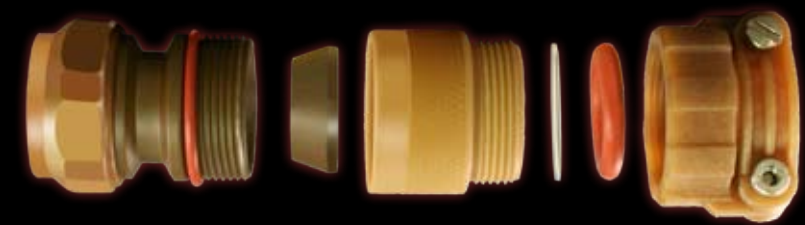
# Glenair®

## Composite Thermoplastic Connectors and Accessories

*Plus Composite Enclosures, Conduit Systems,  
Braided Shielding, Assembly Tools and More!*

United States ■ United Kingdom ■ Germany ■ France ■ Nordic ■ Italy ■ Spain ■ Japan

## Four Reasons to Choose Composites for Your Next Interconnect Application



*Glenair's composite interconnect components are manufactured from high-grade engineering thermoplastics for the toughest application environments. Specifically geared for high-performance air, sea, land and space applications, Glenair's line of composite connectors and backshells are ideally suited for systems which require electromagnetic compatibility, reliable environmental protection and long-term durability. Here's why:*

**Corrosion Resistance:** One of the most appealing attributes of composites is their unlimited corrosion resistance as compared to conventional metal materials. Aluminum interconnect components, for example, are subject to galvanic coupling which causes the material to be "sacrificed" to its cadmium/nickel plating. Since high-temperature composite plastic is not sacrificial to plating, finished products last longer, require less maintenance and so directly reduce the overall cost of ownership of the interconnect system.

**Vibration Dampening:** Unlike metals, polymer plastics are less subject to harmonic resonance due to their lighter weight and inherent attenuating properties. Which means threaded components made from these materials are far less likely to vibrate loose when subjected to prolonged periods of vibration and shock. Again, reduced maintenance and reduced cost of ownership are the major benefits realized by systems built from vibration dampening composite thermoplastics.

**Weight Reduction:** Composites offer increased strength at lighter weights. Weight savings for composites over aluminum are approximately 40% (depending on component design). Savings versus other materials are even more pronounced: up to 80% for stainless steel and brass. Composite materials directly reduce aircraft empty weights and increase fuel fractions—resulting in smaller, lower-cost aircraft that use less fuel to perform a given mission.

**Durability:** Glenair's line of composite thermoplastic interconnect components are cleverly designed to avoid many of the durability problems associated with conductive plated parts. Through the use of selective plating—which limits easy-to-scratch plated surfaces to the protected portions of the part—Glenair has effectively eliminated superficial damage to coupling nuts, saddle bars and box exteriors. The parts are free from visible wear-and-tear problems that forces premature replacement of backshells, connectors, box assemblies and other EMC interconnect components.

# The World's Largest Selection of Tooled Composite Thermoplastic Connectors and Accessories

Strain Relief Backshells

Convuluted Tubing and Fittings

Swing-Arm Strain Relief Clamps

Protective Covers

Micro D Backshells

AmberStrand® Braided Shielding

Swing-Arm with Shield Sock

Overmolded Cable Adapters

Ultra Low-Profile Banding Backshell

Fiber Optic Banding Backshells

EMI/RFI Enclosures

Band-in-a-Can Backshells

Shorting Cap Backshells

Ultra-Light Banding Strain Relief

Non-Environmental Backshell

Feed-Thru Fittings

EMI Lamp Base Thread Backshells

E-Nuts

EMI/RFI Environmental Backshell

Cone and Ring Style EMI/RFI Backshells

Dual Banding Backshells

Knit-Braid EMI/RFI Backshells

Low Profile Strain-Relief

D38999 Type Connectors

Qwik-Ty Strain Relief

Environmental Backshells

Strain Relief Clamps

EMI/RFI Shield Socks

Conduit Fittings

Split Rings

Extender Backshells

Fiber Optic Backshells

Multi-Port Junction Boxes



# Composite Thermoplastic Connectors and Accessories

Product Selection Guide and Technical Information: Intro Pages 2-36

**A** Circular and Rectangular Backshells and Accessories



**A**

**B** Protective Covers and Dummy Stowage Receptacles



**B**

**C** Convoluted Tubing Wire Protection Systems



**C**

**D** EMI/RFI Braided Shielding and Banding Split-Rings



**D**

**E** EMI/RFI Junction Boxes



**E**

**F** MIL-DTL-38999 Series III Type Environmental Connectors



**F**

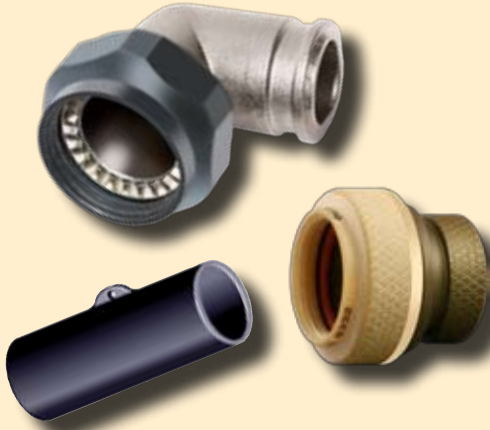
**G** Assembly Tools



**G**

Part Number Index: Inside Back Cover

## 310 - Shrink Boot/Overmold Adapter



Glenair composite shrink boot adapters are designed for use in open-wire bundle cable assemblies that require the splash-proof environmental protection and light-duty strain-relief provided by lipped-type shrink boots such as Glenair 770-001 heat moldable shrink boots. These simple adapters can also be used to accommodate overmolding compounds typically applied to fully-environmental, jacketed cables. The adapters are attached to standard circular connectors and can be plated to provide an EMC ground path. Our composite shrink-boot and overmold adapters are a perfect, light-weight choice for high-performance cable assemblies. The two styles are available for most circular connectors.

Description	Part Number	Page
Shrink Boot Adapter with Rotatable Coupling Nut ; Straight	310-045	A-2
Shrink Boot Adapter with Direct Coupling - Straight	310-017	A-4

## 311 - EMI/RFI Lamp Base Thread Backshell



A sleek, compact shield termination backshell assembly that utilizes a simple lamp-base thread device to capture conductive cable shielding; yielding both strain relief and EMI/RFI protection. Straight and 90° shell styles are available. This simple, light-weight backshell may optionally be equipped with a shrink-boot for a modicum of environmental protection.

Description	Part Number	Page
Lamp Base EMI/RFI Shield Termination Backshell - Straight and 90°	311-034	A-5
Lamp Base EMI/RFI Shield Termination Backshell with Shrink Boot Porch - Straight, 45° and 90°	311-019	A-6
Lamp Base EMI/RFI Environmental Adapter with Shrink Boot Porch and Direct Coupling - Straight	311-063	A-8

## 319 - EMI/RFI Shield Sock Assemblies



Glenair shield sock assemblies offer an alternative strain relief and shield termination solution for shielded, jacketed cable assemblies. Two basic styles are available; with fixed position or user-adjustable entry angles. Made from high-temperature composite thermoplastic, these rugged assemblies offer easy installation, long term durability, and outstanding weight and cost reduction. The products are equipped with reliable "click-style" self-locking rotatable coupling nuts. Available shielding includes standard metal braid as well as light-weight metal clad composite shielding. The shield sock's braid is terminated directly to the cables own braid with *BAND-IT*® bands and tools.

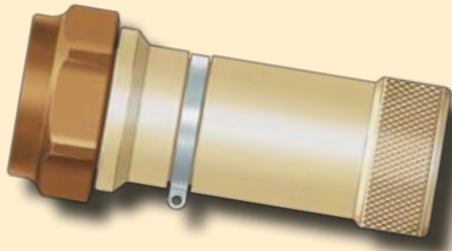
Description	Part Number	Page
Composite Thermoplastic Shield Sock Assembly Procedure		A-10
Swing Arm Backshell with Shield Sock and Self-Locking Rotatable Coupling - Adjustable to Straight, 45° and 90°	319-064	A-12
EMI/RFI Backshell with Shield Sock and Self-Locking Rotatable Coupling - Straight Only	319-120	A-14
EMI/RFI Banding Backshell Shield Sock with Shrink Boot Porch and Self Locking Rotatable Coupling - Straight, 45° and Ultra Low Profile 90°. Uses Micro Band to Attach Shield	319-134	A-16
EMI/RFI Shield Sock Strain Relief with Shrink Boot Porch and Self Locking Rotatable Coupling - Straight, 45° and 90°	319-136	A-18
Shield Sock Strain Relief with Self Locking Rotatable Coupling - Straight, 45° and 90°	319-137	A-22
"Wide Mouth" Swing Arm Strain Relief with Shield Sock and Self Locking Rotatable Coupling - Straight, 45° and 90°	319-138	A-24

## 320 - Extender Backshells

These simple composite backshells—when used with connectors with crimp and poke contact termination—provide extensions between the connector and strain relief, offering the convenience of additional space to accommodate service loops, re-terminations, diodes, resistors and other uses.



Description	Part Number	Page
Extender Backshell with Self-Locking Rotatable Coupling - Straight, 45° and 90°	327-060	A-26



### 347 - Shorting Cap Backshells

Composite Shorting Cap Backshells provide a complete enclosure for the rear of panel-mounted receptacle connectors, and are also adaptable to the fabrication of shorting plugs, special purpose test connectors, or installation of discrete components. Shorting cap backshells also provide an ideal enclosure for fiber optic loop backs used in circuit testing.

Description	Part Number	Page
Shorting Cap Backshell with Lanyard Attachment and Self Locking Rotatable Coupling	347-129	A-28

### 360 - Non-Environmental Backshells with Strain Relief

Glenair provides straight and angled composite backshells with strain reliefs—including standard cable clamps and Glenair's patented Qwik-Clamp—for light and general duty applications where environmental protection of cable-to-connector terminations is not required.



Description	Part Number	Page
Series 360 Non-Environmental Backshell Assembly Instructions		A-30
Non-Environmental Backshell with Self Locking Rotatable Coupling and Strain Relief - Straight and 90°	360-014	A-32
Non-Environmental Backshell with Self Locking Rotatable Coupling and Qwik-Clamp - Straight, 45° and 90°	360-015	A-34

### 370 - Environmental Backshell with Strain Relief

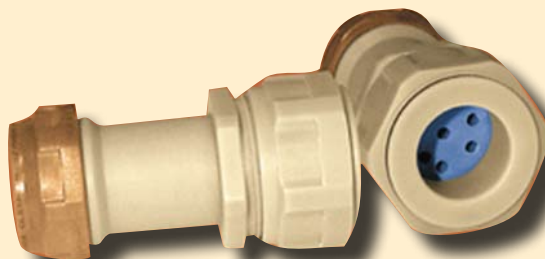


Glenair composite environmental backshells with strain-relief are perfectly suited for the broad range of interconnect cable applications that require reduced weight and serious corrosion protection. Glenair makes both straight and angled versions for all popular connector series and sizes. Two basic versions are available: a standard saddle-clamp version and our patented Qwik-Clamp.

Description	Part Number	Page
Series 370 Environmental Backshell Assembly Instructions		A-36
Cable Sealing and Environmental Backshell with Self Locking Rotatable Coupling and Strain Relief Clamp or Nut - Straight or 90°	370-016	A-38
Cable Sealing and Environmental Backshell with Self Locking Rotatable Coupling and Qwik-Clamp or Nut - Straight or 90°	370-017	A-40

## 377 - Fiber Optic Backshells

Glenair composite fiber optic backshells provide protection and alignment of individual optical fiber media in open-bundle and jacketed cable assemblies. Straight, and 90° angled fittings are available for added convenience in fiber cable routing. The 90° angled versions utilize a smooth, sweeping profile to eliminate micro-bending of fiber media.



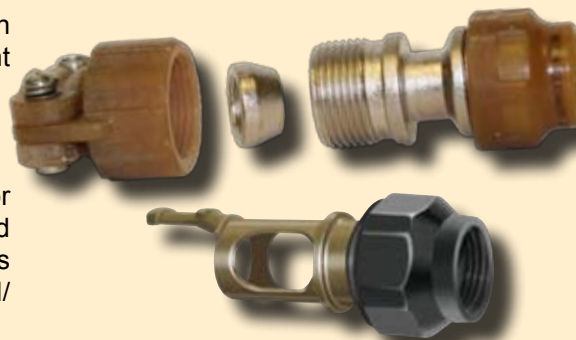
Description	Part Number	Page
Fiber Optic Strain Relief Backshell with Self Locking Rotatable Coupling and Fiber Alignment Grommet and Optional Banding adapter or Nut	377-040	A-42

## 380 - EMI/RFI Non-Environmental Backshells

Glenair's composite EMI/RFI Shield Termination Backshell family includes a range of reliable and convenient termination methods, including:

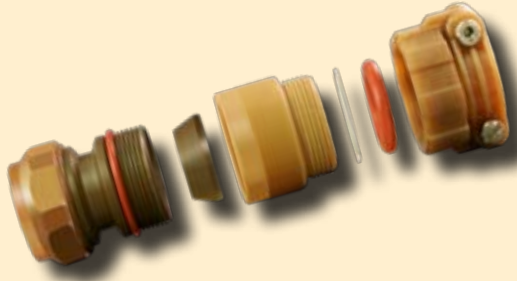
- Cone and Ring Style backshells, and
- Ultra lightweight "Knit Braid" designs

Each style offers a repairable termination method ideal for field service of damaged connector contacts in both jacketed and open-wire bundle cable assemblies. The 380 series is non-environmental. For cable sealing backshells with EMI/RFI shield termination see Series 390.



Description	Part Number	Page
Series 380 EMI/RFI Non-Env. Backshell Assembly Instructions (Type D)		A-44
Series 380 EMI/RFI Non-Env. Backshell Assembly Instructions (Type E)		A-56
Cone and Ring Style Shield Termination Backshell with Self Locking Coupling Nut and Strain Relief - Straight and 90°	380-099	A-46
Cone and Ring Style EMI/RFI Backshell with Self Locking Rotatable Coupling and Qwik-Clamp - Straight, 45° and 90°	380-100	A-48
Knit Braid Style EMI/RFI Shield Termination Backshell with Qwik-Ty and Rotatable Coupling	380-130	A-52
Knit Braid Style EMI/RFI Shield Termination Backshell with Clamp and Rotatable Coupling	380-131	A-53
Knit Braid Style EMI/RFI O-Ring Equipped Shield Termination Backshell with Shrink Boot Adapter and Rotatable Coupling	380-132	A-54
EMI/RFI Nickel Plated Copper Knit Braid Material	107-044	A-55
Multi Shield Cone and Ring Style EMI/RFI Shield Termination Backshell with Self Locking Rotatable Coupling and Strain Relief	387-083	A-58

### 390 - EMI/RFI Environmental Backshells



Glenair's composite Series 390 backshells utilize standard cone and ring style shield termination to deliver 360° shield/screen grounding with low DC resistance across the termination area. Cable sealing O-rings provide full-immersion protection to 6 ft. The lightweight, corrosion proof backshell is ideally suited to general duty use in both military and commercial interconnect cable applications. Glenair 390 series backshells are fully tooled for all popular connector series and sizes.

Description	Part Number	Page
Series 390 EMI/RFI Environmental Backshell Assembly Instructions		A-60
Environmental Cone and Ring Style EMI/RFI Shield Termination Backshell with Self Locking Rotatable Coupling and Strain Relief - Straight, 45° and 90°	390-052	A-62

### 440 - EMI/RFI Banding Backshells



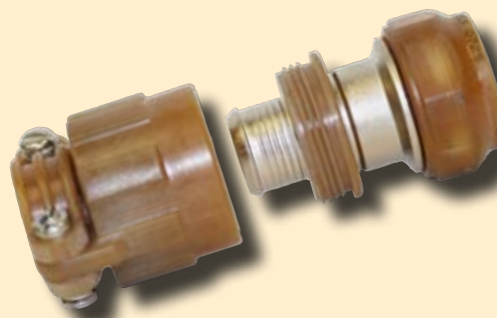
Banding is by far the most popular and reliable method of EMI shield termination used today in high-performance cable assemblies. Glenair supplies composite banding backshells in straight, 45° and 90° entry angles, with accommodation for either standard or lighter weight and duty micro *BAND-IT*® bands. Various configurations are available—all made from lightweight composite thermoplastic.

Description	Part Number	Page
Banding Backshell Assembly Instructions		A-66
Ultra Lightweight Banding Strain Relief with Rotatable Coupling	440-087	A-64
EMI/RFI Micro-Banding Backshell with Qwik-Ty Strain Relief, Shrink Boot Groove and Self Locking Rotatable Coupling - Straight, 45° and Ultra Low Profile 90°	440-143	A-68
EMI/RFI Micro-Banding Backshell with Shrink Boot Groove and Self Locking Rotatable Coupling - Straight, 45° and Ultra Low Profile 90°	440-144	A-70
EMI/RFI Banding Backshell with Shrink Boot Groove and Self Locking Rotatable Coupling - Standard Profile Straight, 45° and 90°	447-325	A-72
EMI/RFI Micro-Banding Backshell with Shrink Boot Groove and Self Locking Rotatable Coupling - Standard Profile Straight, 45° and 90°	447-326	A-74
EMI/RFI Banding Backshell with Qwik-Ty Strain Relief and Shrink Boot Groove - Standard Profile Straight and 90°	447-327	A-76
EMI/RFI Dual Banding Backshell with Self Locking Rotatable Coupling - Straight and 90°	447-331	A-84
EMI/RFI Banding Backshell with Strain Relief - Standard Profile Straight and 90°	447-711	A-87



## 447 - EMI/RFI Band-in-a-Can

The Glenair Series 447 Band-in-a-Can backshell combines the convenience of banding with the versatility of a standard saddle bar strain-relief. The 447 series is available in both single and dual banding porch designs, as well as an optional Qwik-Clamp strain-relief version. The Band-in-a-Can is a perfect solution for standard shielded and jacketed cable assemblies. The selectively plated product offers 360° shield grounding without the wear-and-tear problems usually associated with plated interconnect products.



Description	Part Number	Page
EMI/RFI Band-in-a-Can Backshell with Strain Relief Clamp - Standard Profile Straight and 90°	447-328	A-78
EMI/RFI Environmental Band-in-a-Can Backshell with Strain Relief Clamp or Qwik-Clamp – Standard Profile Straight and 90°	447-329	A-80
EMI/RFI Non-Environmental Band-in-a-Can Backshell with Qwik-Clamp and Self-Locking Rotatable Coupling – Standard Profile Straight and 90°	447-330	A-82
EMI/RFI Low Profile Micro Band-in-a-Can Backshell with Strain Relief Clamp	447-657	A-86

## 450 - Qwik-Ty Strain Reliefs

Glenair's Qwik-Ty® strain reliefs offer a unique method of providing strain relief to open wire bundles equipped with circular connectors. The Qwik-Ty® comes in straight, 45° and 90° configurations, and features a low profile, reduced weight and simple installation. Assembly with plastic tie straps or lacing tape is quick and secure.



Description	Part Number	Page
Qwik-Ty Strain Relief with Self Locking Rotatable Coupling - Straight, 45° and Low Profile 90°	450-029	A-88
Qwik-Ty Strain Relief with Ground Lug and Self Locking Rotatable Coupling - Straight, 45° and Low Profile 90°	450-030	A-89
Ultra Lightweight Qwik-Ty Strain Relief with Free Rotating Coupling - Straight and Low Profile 90°	450-034	A-90

### 550 - EMI/RFI Rectangular Backshells

Glenair's line of rectangular backshells is the largest in the industry. The short list of composite thermoplastic versions shown here provide EMI protection for rectangular connectors used in harsh or severe operating environments. Our D-Subminiature and Micro-D versions are both available in top, side and 45° entry configurations, in a full range of conductive and non-conductive finishes.



Description	Part Number	Page
EMI/RFI Banding Backshell for MIL-DTL-83513 Micro-D Connectors - Top, 45° and Side Entry	507-088	A-92
EMI/RFI Banding Backshell for MIL-DTL-24308 D-Subminiature Connectors - Top, Side and End Entry	557-186	A-94

### 610 - "E" Nuts



"E" Nuts are typically used on the back of connectors with no EMI/RFI, environmental or strain-relief requirement. But since many OEMs require that all connectors be equipped with a backshell, the "E" nut fills the threads on the back of the connector and compresses the sealing grommet—all without the added bulk or weight of a standard backshell. Composite "E" Nuts are available in both plated and unplated designs for all popular connector series and sizes.

Description	Part Number	Page
"E" Nut Backshell	610-014	A-96



### 620 - Strain Relief Clamps

Glenair offers a comprehensive selection of composite strain reliefs for circular connectors. Straight, 45° and 90° styles are available to fit most common connector types. Saddle clamps tighten around the cable assembly to ensure it remains in place— even in the face of potentially damaging tugs or twists.

Description	Part Number	Page
Composite Saddle Clamp Assembly Procedure		A-20
Strain Relief Clamp with Self-Locking Rotatable Coupling - Straight, 45° and 90°	620-042	A-97
Swing Arm Strain Relief with Self Locking Rotatable Coupling Nut	627-122	A-98
Swing-Arm Strain Relief with Keyed Banding Insert	627-142	A-100

## 630 - Thru-Box, Panel and Bulkhead Fittings



Glenair manufactures a full-spectrum line of feed-through fittings for routing wire and cable into and out of switchgear and other types of junction boxes. The composite fittings in this section are ideal for thru-panel and bulkhead applications in harsh environmental settings.

Description	Part Number	Page
EMI/RFI Environmental Thru-Box, Panel and Bulkhead Banding Adapter - Front or Rear Mount	630-030	E-36
Universal Environmental Thru-Box, Panel and Bulkhead Universal Adapter	630-031	E-38
EMI/RFI Environmental Box Feedthru Cable / Conduit Adapter	637-094	E-40

## 770 - Shrink Boots

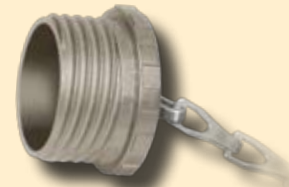
Glenair offers a standard range of adhesive and non-adhesive heat moldable shrink boots for use with our metal and composite backshells. Shrink boots provide strain relief and environmental protection in non-jacketed cable and/or conduit assemblies.



Description	Part Number	Page
Heat Moldable Shrink Boot - Straight and 90°	770-001	A-102

## 660 - Protective Covers and Stowage Receptacles

Protective covers are a critical component in interconnect systems where maintenance and test cycles can lead to damage of exposed connectors. Conductive and non-conductive plating options are available to match the conductivity and impedance requirements of the application and the connector.



Description	Part Number	Page
MIL-DTL-5015 Plug and Receptacle Covers	660-045 / 046	B-3
MIL-DTL-28840 Plug and Receptacle Covers	660-047 / 048	B-4
MIL-DTL-38999 Series III Plug and Receptacle Covers	660-049 / 050	B-5
Glenair Series 190-015 / 016 Plug and Receptacle Covers	660-077 / 078	B-6
MIL-DTL-83723 Series III Plug and Receptacle Covers	660-051 / 052	B-7
MIL-DTL-38999 Series III Dummy Stowage Receptacle	650-025	B-8
MIL-DTL-38999 Series III Receptacle Cover with Anti-Decoupling Device	667-117	B-9
MIL-DTL-5015 Receptacle Cover with Anti-Decoupling Device	667-118	B-10
MIL-DTL-38999 Series III Receptacle Cover with Anti-Rotation Device	667-079	B-11

## 740 - Convoluted Tubing Wire Protection Systems

Glenair's supplies a number of lightweight, flexible wire circuit protection solutions made from high-temperature polymer plastics. These polymer convoluted tubing products provide extremely rugged, lightweight enclosures for wiring systems deployed in harsh application environments. The crush-resistant materials offer exceptional flexibility and abrasion resistance, and can be combined with Glenair composite end-fittings, transition-fittings, EMI braiding and jacketing to meet almost any installation requirement. In addition to a complete range of DuPont™ Teflon® tubing types (PTFE, FEP, ETFE and so on), Glenair also offers a low-outgassing halogen-free polymer called PEEK that far out performs other plastic tubing formulas in its strength to weight ratio and has a V-O flammability rating down to 0.057 inches without the use of additives.



Description	Part Number	Page
Type A - Convoluted Tubing Only - Series 74 Convoluted Tubing	120-100	C-7
Type B - External Black Dacron® Braid - Series 74 Convoluted Tubing	120-103	C-8
Type C - External Shield and Jacket - Series 74 Convoluted Tubing	121-100	C-9
Type D - External Shield - Series 74 Convoluted Tubing	121-101	C-10
Type E - Two External Shields - Series 74 Convoluted Tubing	121-102	C-11
Type F - Jacket and Two External Shields - Series 74 Convoluted Tubing	121-103	C-12
Type G - External Jacket - Series 74 Convoluted Tubing	123-100	C-13
Fiber Optic Conduit Backshell Adapter with Self Locking Rotatable Coupling and Fiber Alignment Grommet	377-041	C-14
"T" Configuration Split Junction Fitting	710-318	C-16
"Y" Configuration Split Junction Fitting	710-319	C-17
Straight with 45° Branch Configuration Split Junction Fitting	710-320	C-18
Plus "+" Configuration Split Junction Fitting	710-321	C-19
Shrink Boot Conduit Fitting for Glenair Series 74 Helical Convoluted Tubing	712S269	C-20
Single EMI/RFI Shield Termination Conduit Fitting for Glenair Series 74 Helical Convoluted Tubing	712S270	C-21
Dual EMI/RFI Shield Termination Conduit Fitting for Glenair Series 74 Helical Convoluted Tubing	712S271	C-22
Straight, 45° and 90° Conduit Connector Adapter for Glenair Series 74 Helical Convoluted Tubing	712-419	C-24

Teflon® is a registered trademark of E. I. du Pont de Nemours and Company

## 103 - EMI/RFI Braided Shielding and Banding Split-Rings

For many applications, the cable shield is the most important element in controlling EMI. Unfortunately, metal shielding—especially when applied in multiple layers—can be extremely heavy. The opportunity to provide conductive EMI shielding at a fraction of the weight of metal is the principal advantage of composite thermoplastic EMI/RFI shielding\*. Glenair is the industry leader in the design and manufacture of these unique screening products, supplied both in 100% composite and hybrid metal/plastic configurations.

As is commonly used in conjunction with composite shield socks, the banding split ring is a useful accessory that protects wire conductors from damage in shield-to-shield terminations.

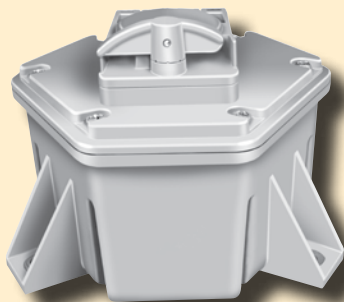
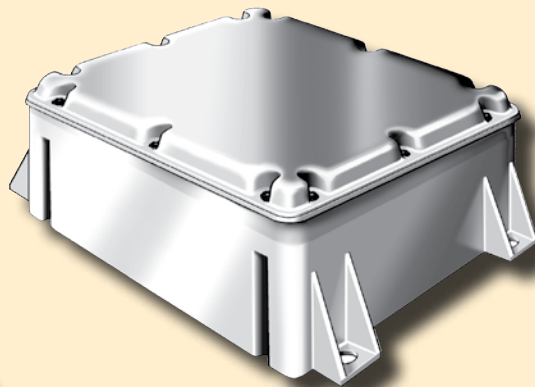


Description	Part Number	Page
Composite Light Weight Metal-Clad EMI/RFI Braided Shielding (100%)	103-026	D-2
75%/25% Blended Composite/Metal EMI/RFI Braided Shielding	103-027	D-3
PEEK Tubular Braid (Black) for Series 74 Convuluted Tubing	102-051	D-4
AS85049 Composite Banding Split-Ring	687-749	D-5

\*Glenair's composite light weight metal-clad EMI/RFI braiding is made from AmberStrand®

### 140 - Composite EMI/RFI Junction Boxes

Glenair's lightweight/high-strength "CostSaver" Composite EMI/RFI Junction Boxes are ideally suited for use in harsh environments, where resistance to electromagnetic interference, corrosive fluids, high temperatures, shock and vibration are critical requirements. The boxes are designed to meet the shock and vibration requirements of MIL-S-901D and MIL-STD-167SHIPS. Box materials also meet stringent EMI/RFI/HIRF and indirect lightning strike performance specifications.



Description	Part Number	Page
Ultra-Miniature Junction Box	140-074	E-16
Mini Junction Box	140-100	E-18
Small Junction Box	140-101	E-20
Medium Junction Box	140-102	E-22
Large Junction Box	140-103	E-24
Small Low-Profile Box	140-104	E-26
Medium Low-Profile Junction Box	140-105	E-28
Small Three-Legged Junction Box	140-106	E-30
Jumbo Junction Box	140-107	E-32
8 Port Octagonal Junction Box	140-200	E-34
12 Port Rectangular Junction Box	140-203	E-35
Internal Mounting Plate for use with Rectangular Series Boxes	687-466	E-42
Round Internal Mounting Plate for use with 140-106 Box	687-305-22	E-43
Slotted Terminal Block Mounting Rail	687-467	E-44
Hole Cap Assembly	687-461	E-45

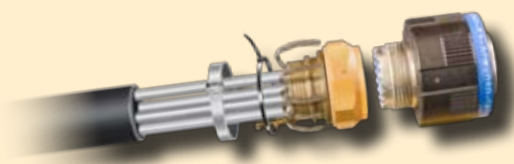
## MIL-DTL-38999 Series III Type Environmental Connectors

Glenair's composite MIL-DTL-38999 Series III Type Environmental Connector Series is built to ensure robust, durable performance. Connector polarization keys and keyways are manufactured to extremely tight tolerances, facilitating reliable mating and minimizing mating cycle wear. Composite shell bodies offer reduced weight, excellent environmental performance and reliable resistance to vibration and shock. Resilient elastomer inserts and heat-treated beryllium copper contact retention clips provide trouble-free crimp contact insertion and removal. Insert arrangements are IAW MIL-STD-1560, or appropriate sub-sets depending on intended application. Consult factory for available insert arrangements.



Description	Part Number	Page
MIL-DTL-38999 Series III Type Wall Mount Receptacle	233-105-00, D0, T0	F-10
MIL-DTL-38999 Series III Type Jam Nut Receptacle	233-105-07	F-12
MIL-DTL-38999 Series III Type In-Line Receptacle	233-105-05	F-14
MIL-DTL-38999 Series III Type Plug	233-105-G6	F-16

## Composite Connector Accessory Assembly Procedures



Glenair assembly procedures are provided for shield termination backshells and other complex assemblies. Below is a list of the assembly procedures in this book. Please consult factory for additional assistance.

Assembly Instructions	Page
Composite Thermoplastic Shield Sock Assembly Procedure	A-10
Series 360 Non-Environmental Backshell Assembly Instructions	A-30
Series 370 Environmental Backshell Assembly Instructions	A-36
Series 380 EMI/RFI Non-Env. Backshell Assembly Instructions (Type D)	A-44
Series 380 EMI/RFI Non-Env. Backshell Assembly Instructions (Type E)	A-56
Series 390 EMI/RFI Environmental Backshell Assembly Instructions	A-60
Banding Backshell Assembly Instructions	A-66
Composite Saddle Clamp Assembly Procedure	A-20
Composite Accessory-to-Connector Assembly Instructions	G-3
Band-It® Shield Termination Assembly Procedure	G-11

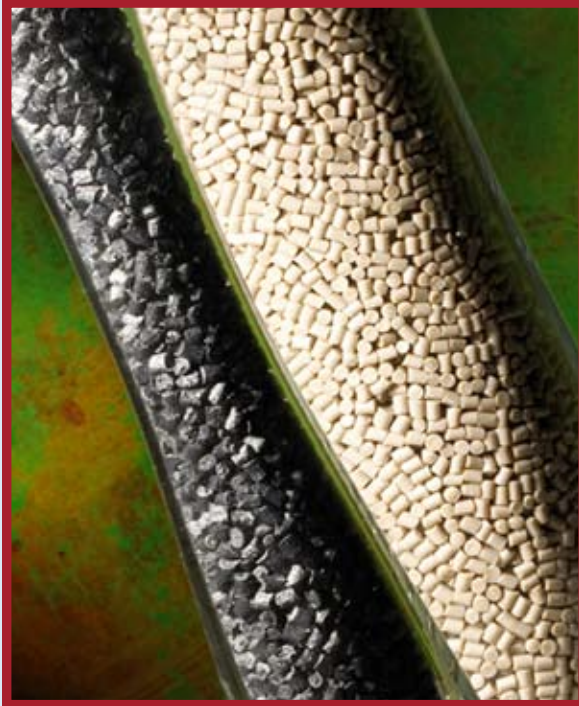
### Tools and Tool Accessories

Glenair addresses interconnect system assembly requirements with a variety of military standard and specialized connector-to-backshell assembly tools, braided shielding banding tools and accessories. Our tool line for composite components includes backshell-to-connector assembly wrenches specifically designed to fit composite coupling nut dimensions.



Description	Part Number	Page
Soft Jaw Pliers	TG69	G-5
Aluminum Hex-Coupling Wrench for Composite Backshells	600-091	G-6
Stainless Steel Hex-Coupling Wrench for Composite Backshells	600-157	G-7
Backshell Assembly Strap Wrench with 3/8" Square Drive	TG70	G-8
Hand-Held Digital Torque Wrench with Dual 3/8" Drives	600-161	G-9
Bench Stand for 600-161 Digital Torque Wrench	600-162	
Large Broad Blade Utility Shears	600-164	G-10
Hand Banding Tool for Standard Bands	600-058	G-12
Hand Banding Tool for Micro Bands	600-061	
Standard Clamping Band	600-052	G-13
Standard Extended-Length Clamping Band	600-090	
Micro Clamping Band	600-057	
Micro Extended-Length Clamping Band	600-083	
Cut-Off Blade for Standard Hand Banding Tool	600-056	G-14
Cutter Knife for Standard Hand Banding Tool	600-062	
Cut-Off Blade for Micro Banding Tool	600-060	
Cutter Knife for Micro Banding Tool	600-082	G-15
Calibration Key for Standard and Micro Hand Banding Tools	600-055	
Tension Gauge for Standard Hand Banding Tools	600-072-1	
Tension Gauge for Micro Hand Banding Tools	600-086-1	





*Glass-filled composite thermoplastic resins in pellet form, ready for use in injection molding applications.*

Generally, when we speak of “composites,” we refer to materials containing fibers, primarily glass, impregnated within a plastic resin or “matrix”. This combination produces strong, lightweight, corrosion-resistant and dimensionally stable materials. Such materials also provide design flexibility and high dielectric strength.

Glass fiber and resin complement each other well. Just as a metallurgist might combine tin and copper to produce bronze—a material which is much stronger than either base metal by itself— combining glass fiber with a resin matrix results in a material that is more useful than either of its constituent components is on its own.

Certain plastics are extremely strong yet subject to cracking or other forms of stress-related damage. When the plastic matrix is augmented with glass fibers, a wide range of performance benchmarks can be achieved including improved wear-resistance, crush-resistance, and dimensional stability.

Glenair composite interconnect components are principally manufactured from 30% glass fiber polyetherimide (PEI), an amorphous thermoplastic with outstanding heat and chemical resistance and high strength. At room temperature the 30% glass filled PEI exhibits strength far beyond that of most engineering thermoplastics, with a tensile strength yield of over 15,000 psi. The PEI material meets the most stringent outgassing and flammability requirements.

### Composite Thermoplastic Vs. Common Metal Materials

Material	Specific Gravity	Density (lbs. Inch <sup>3</sup> )	Salt Spray
Composite	1.27 - 1.51	.055	2000+ Hrs
Aluminum	2.55 - 2.80	.098	48-1000 Hrs
Titanium	4.51 - 4.62	.162	500-1000 Hrs
Stainless Steel	7.70 - 7.73	.284	500-1000 Hrs
Brass	8.40 - 8.70	.305	500-1000 Hrs



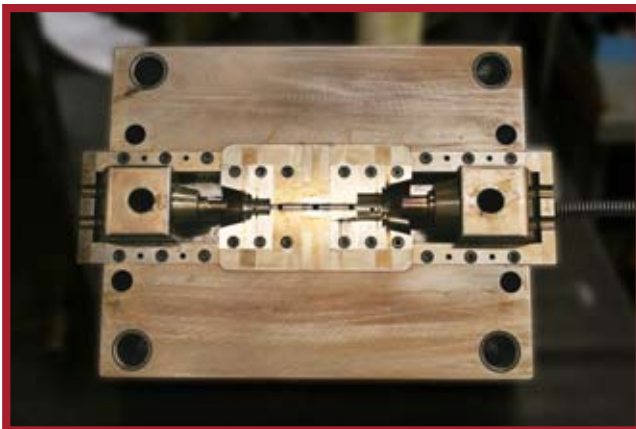
## Glenair Composite Connector and Accessory Production Capabilities

Glenair is the recognized leader in composite thermoplastic research and development for the interconnect accessory industry. In fact, no one else has tooled even a small fraction of the composite thermoplastic accessories available today from Glenair. The product line includes circular and rectangular connectors and accessories, cable junction boxes, conduit, conduit fittings, protective covers, shielding, shielding support rings, and more. It is an ongoing goal at Glenair, largely achieved at this point, to be able to offer equivalent function composite thermoplastic interconnect components for the complete range of interconnect products we produce in metal.

Glenair composite components are produced in injection molded and, in certain cases, machined versions ideally suited for use in harsh environments where resistance to high temperatures, outgassing, corrosive fluids, fire, and shock and vibration is required. Glenair composites are ASTM E595 space rated, and are qualified to the shock, vibration, thread strength and bend moment requirements of MIL-DTL-38999 and SAE AS85049. The materials also meet stringent EMI/RFI/HIRF and indirect lightning strike performance specifications.

Glenair has the largest and most experienced staff of composite engineers and manufacturing experts in the interconnect accessory industry. Their combined expertise insures Glenair composite products mate correctly with both

metal and composite connectors and meet the customer's most stringent performance requirements. All Glenair designs provide a dimensionally stable and cadmium-free alternative to plated aluminum and brass.



Glenair composite material options include Ultem® (PEI), Amodel® (PPA), Ryton® (PPS), Torlon® (PAI), PEEK, Siltem and LCP. Base materials can be augmented with conductive and non-conductive additives and reinforcing fibers to meet specific functional specifications. As mentioned, each composite material has its own specific structural properties. The following is a brief introduction to the most common materials used by Glenair:

## Glenair Composite Connector and Accessory Production Capabilities



Ultem® (PEI) is an amorphous thermoplastic available in extruded bars for machining and pellets for injection molding. It combines high performance with good processing characteristics and offers high heat resistance, high strength



*Glenair stocks an abundant supply of the composite materials used in the fabrication of our parts.*

Ryton® (PPS) is a high temperature, injection molded material. It has good mechanical properties and excellent chemical resistance at elevated temperatures. Different grades are available including glass filled and glass/mineral filled versions. Ryton R4-XT is a 40 percent glass filled version engineered for improved knit-weld line characteristics. As a semi-crystalline material, Ryton exhibits excellent resistance to prolonged exposure to high temperatures, up to 500° F (260° C). Ryton also provides outstanding resistance to a broad spectrum of aggressive chemicals and has very stable dielectric and insulating properties. Ryton meets ASTM E595 outgassing requirements and UL94 flammability tests.

Glenair's G-FLEX polymer (polyetherimide-siloxane) is a high-temperature material used primarily to produce annular convoluted tubing. The material is offered in a broad range of operating temperatures, has exceptional flexibility and good crush resistance. In certain applications, G-FLEX is a suitable alternative to costlier halogen-free composite polymers such as PEEK (polyetheretherketone). PEEK is a semi-crystalline thermoplastic that operates at extremely high temperatures—500°F (260° C) long-term and 600°F (315° C) short term. An extrudable material, PEEK offers one of the lightest strength to weight ratios available in a composite.

modulus and broad chemical resistance. Ultem 2300 is a 30% glass filled thermoplastic which displays excellent property retention and resistance to environmental stress. It can be further reinforced with conductive fibers, or plated, for EMI resistance. Ultem performs in operating environments up to 378° F (192° C) long term and 410° F (210° C) short term. Ultem meets ASTM E595 outgassing, 14 CFR Part 25 flammability, and zero halogen outgassing requirements.



## Glenair Composite Connector and Accessory Application Design Considerations

### Cost Comparison and Temperature Resistance

For many people, “plastic” means “cheap and breakable.” But when engineers search for new ways to enhance weight savings, corrosion resistance, shock and vibration dampening and stealth they immediately turn to plastic—the only alternative material capable of meeting, and beating, the established performance levels of aluminum, brass, titanium and steel.

The name “plastic” refers to the ability to form or shape a material, or to the moldability a material adopts under forces such as pressure or heat. Engineers often use the term “polymer” when referring to plastic materials, because it more clearly describes how many (poly) chemical units (mers) form up in complex chains to create modern plastic resins. “Thermoplastics” are polymer materials that melt to a liquid when heated and form into a hard, dimensionally stable shape when cooled.

Thermoplastic polymers are created by subjecting various chemical and petroleum-



*The glass transition temperature, or the point at which the heated resin will soften, varies from material to material. Extremely high-heat applications, such as engine sensors, are generally considered to be ill-suited for composites.*

based ingredients to heat and pressure in sealed vessels. Specific chemical additives control how the polymer is formed and contribute to its performance in such areas as surface hardness and flame resistance. The process of mixing base materials with chemical additives to create specific types of plastic resins is called “polymerization.” The resulting plastic materials can be classified in various ways—by chemical or physical structure, by strength or thermal performance and by optical or electrical properties. Thermal properties are extremely important when selecting plastic materials for use in high-performance applications. Composite glass transition temperature (the point at which the heated material softens) will dictate whether or not the plastic is suitable for use in high-heat applications such as adjacent to an engine or other heat source. But other properties, such as its specific gravity, hardness, refractive index, dielectric strength, conductivity, chemical resistance, UV and flame resistance are also critical in deciding which recipe of resins, fibers and additives will be selected for a particular project.

Temperature resistance can be measured in a variety of ways: melt temperature, heat deflection temperature, glass transition temperature, and continuous use temperature. The resins that offer the highest capabilities in each of these categories are often the most expensive, but typically offer the lowest lifetime cost because of enhanced durability and strength. Two of the top thermal performers, Polyetheretherketone (PEEK) and high-temperature ETFE, are high cost materials, but exceptional performers over the long run.

Additives can be used to increase flame retardancy, to improve lubricity or, in the case of pigments, simply to change the color of the final product. Again, material costs can rise with the addition of chemical compounds that contribute to improved performance. In terms of cost, thermoplastic resins can be arranged into three basic categories:

- Low cost/commodity resins with large volume market costs of less than \$1.50/lb
- Medium cost/engineering resins that fall between \$1.50-\$3.00/lb
- High cost/high temperature resistant resins that usually cost above \$3.00/lb.

### **Re-Designing Interconnect Systems for Composite Thermoplastics**

Interconnect products made of composite materials offer significant advantages over steel or aluminum. They're lighter. They don't rust. They don't loosen under vibration. They can hide from radar. Yet the ability to design composite components that take advantage of these properties while still meeting form, fit and function requirements is no simple task.

Connector accessories, no matter the material, must thread onto the back of connectors. Intercompatibility with other components, whether composite or metal, is critical. Composite component design is further complicated due to the unique strengths and weakness of the material. Abrupt changes in wall thicknesses, for example, can lead to stress problems in both manufacture and use. Sharp, un-radiused angles can create stress and cause cracking. The length, shape, orientation and distribution of reinforcing fibers is also a critical concern, as is the impact of other additives, such as colorizers and flame retardants, on the behavior of the material during manufacture and use.

Interconnect systems designers continue to specify composites, despite the complications of the design and manufacturing process. The weight savings, corrosion resistance and other significant advantages of composites represent real, out-of-pocket savings in fuel consumption and lifetime system maintenance for a broad range of air, sea and space applications.

### **Special Applications of Engineering Plastics: Flexible Tubing**

Most of the products in this catalog are made from glass-filled thermoplastic resins, such as PEI (polyetherimide). These Glenair interconnect components—connectors, junction boxes, backshells and so on—are produced in an injection molding process that results in products that are known for their toughness, damage-resistance, dimensional stability and strength. But other formulas of engineering plastics, such as ETFE (ethylene tetrafluorethylene), are also widely applied by Glenair to produce a very different class of products: flexible convoluted tubing.

Unlike glass-filled thermoplastics that produce rigid parts, ETFE, FEP, and other high-temperature plastics used by Glenair in tubing fabrication produce products that are known for their folding endurance, or the number of times the material can be bent or flexed before experiencing failure. Used in wire-protection applications where a rigid, jacketed cable would experience rapid failure, flexible plastic tubing delivers outstanding performance and durability.

Glenair specializes in the manufacture of ruggedized plastic tubing for shipboard, aircraft and ground applications, and offers the world's broadest range of environmental, mechanical and EMI hardened solutions. Our recently expanded convoluted tubing and conduit manufacturing facility in Glendale is a state-of-the-art plant with every step in the tubing extrusion and finishing process centralized under one roof.





## Glenair Composite Connector and Accessory Standard Materials and Finishes

The following standard materials are used for the majority of Glenair's composite products. However, components are not limited to those listed but are representative of the elements used in Glenair's composite products.

Component	Material	Specification
Bodies, clamps, Saddles, coupling nuts, protective covers, etc.	Composite	AIR 4567, AS85049 ASTM D 5205
Hardware: Such as screws, washers, rivets, wire rope, sash chain, band straps, etc.	Corrosion Resisting Steel	QQ-S-763 (300 Series)
Elastomeric seals: Such as o-rings, cable jacket seals, grommets, etc.	Silicone or Fluorosilicone	ZZ-R-765 or MIL-R-25988
Anti-friction and thrust washers	Teflon	TFE

### Standard Finishes

FINISH DETAILS		
SYM	MATERIAL	FINISH
XO	Composite Thermoplastic	No Plating, Natural
XB		No Plating, Black
XZN		Conductive, Zinc Nickel, Black
XM		Conductive, Electroless Nickel
XMT		Conductive, Ni-PTFE <i>1000 Hour Grey™</i>
XW		Conductive, Cadmium O.D. Over Electroless Nickel

### Locking Compound

Glenair recommends  
**ND VIBRA-TITE® Formula 3**  
Thread Locking Compound  
for customers who choose to lock or seal  
fasteners used on composite products.

Available from ND Industries  
([www.ndindustries.com](http://www.ndindustries.com)), this product is  
non-reactive to composite resins

#### FINISH CODE CROSS REFERENCE

Glenair Finish	MIL-DTL-38999	AS85049
<b>XM</b>	<b>M</b>	<b>M</b>
<b>XW</b>	<b>J</b>	<b>J</b>
<b>XMT</b>	<b>T</b>	<b>X</b>

### *1000 Hour Grey™* Ni-PTFE Nickel Fluorocarbon Polymer



The MIL-DTL-38999 Rev L detail specification lists Nickel Fluorocarbon Polymer as a qualified Cadmium free plating alternative. This RoHS compliant plating formula is now available on composite interconnect products from Glenair and offers the following benefits in harsh-environment applications:

- 2000+ hour salt spray
- Cadmium free
- Outstanding mating lubricity
- Hexavalent Chromium free
- 500+ mating cycles
- Non-Magnetic

# RoHS Compliant Plating Option for Composite Thermoplastic Connectors and Accessories



The 30 May 2008 MIL-DTL-38999 Rev L specification provides guidance on the use of alternative parts with less hazardous or nonhazardous materials. In this regard, the specification provides for a number of alternative plating materials. Users are directed to select the least hazardous plating material that meets the form, fit and function requirements of their application.

Glenair would like to draw our customer's attention to one of the finish options from this specification that conforms to this guidance:

**T** – Environment resisting Nickel fluorocarbon polymer. Conductive Nickel with fluorocarbon polymer additives over a suitable underplate to withstand 500 hours of dynamic salt spray testing.

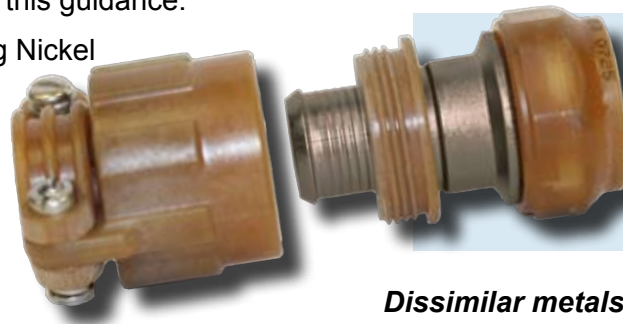
This MIL-DTL-38999L "T" plating solution is cadmium and hexavalent chromium free, which allows it to be defined as RoHS compliant. NOTE: as of this printing the SAE AS85049 committee has not yet defined plating codes for this finish.

Glenair has developed its own Ni-PTFE surface finish that meets all the D38999 requirements but radically outperforms standard nickel fluorocarbon polymer finishes in the most important areas including an amazing 2000 hours dynamic salt spray resistance when plated on composite parts.

This Glenair nickel fluorocarbon polymer plating has been assigned the **XMT** code in the plating tables in this composite catalog. Here are just some of the key performance attributes:

**Temperature Resistance:** Glenair's **XMT Ni-PTFE 1000 Hour Grey™** finish is rated from -65°C to +175°C.

**Plating adhesion:** When tested as specified in 4.5.5, there shall be no blistering, peeling, flaking or separation of plating or other damage detrimental to the operation of the part.



**Glenair Nickel-PTFE 1,000 Hour Grey™ RoHS Compliant Plating is Now Available for All Composite Connector and Accessory Products.**

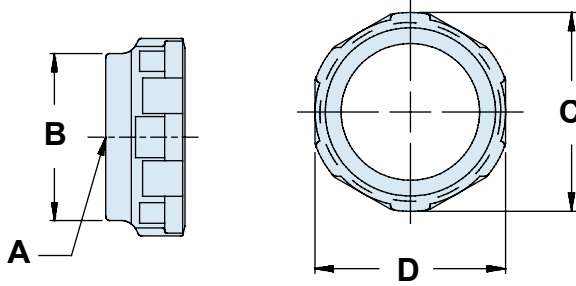
**Dissimilar metals and compatible couples:** The 1000 Hour Grey™ finish satisfies prohibitions against dissimilar metal coupling as specified in MIL-STD-889.

**Shell-to-shell conductivity (millivolts):** The **XMT** finish is rated at 2.5 millivolt drop potential.

**Sulfur Dioxide Resistance:** The **XMT** finish passes the requisite 336 hours resistance to Sulfur Dioxide.

Please note that **XMT** may also be applied to aluminum alloy and stainless steel, in which case the composite marker "X" is dropped and the plating code changes to **MT**.

## Table I Front End Dimensional Details

**NOTES:**

1. Connector shell size designations within   are for reference only; do not use in part numbers.
2. Metric dimensions (mm) are in parentheses and are for reference only. (1 inch = 25.4 mm)
3. Consult factory for accessory interface data not listed.
4. Use Glenair 600-091 or 600-157 tool to tighten coupling nut. Rubber jaw pliers or strap wrench may damage the parts.

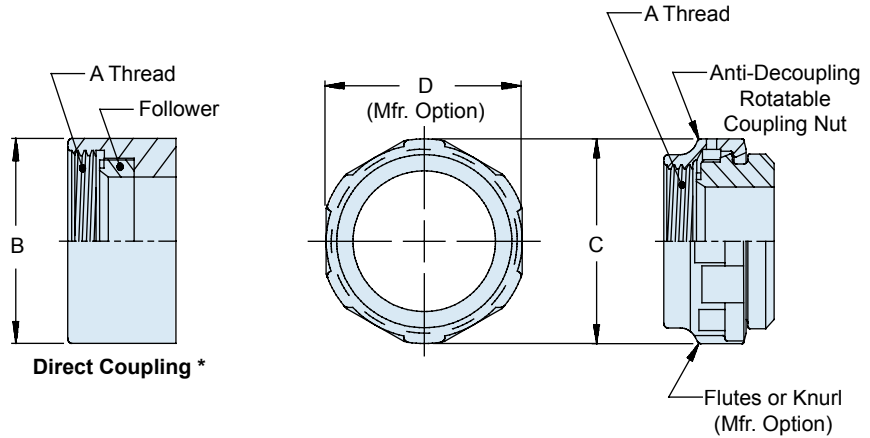
TABLE I									
SHELL SIZE FOR CONNECTOR DESIGNATOR					A THREAD REF	B DIA MAX	C DIA MAX	D FLATS REF	
A	F/L	G	H	U					
-	08 09	-	-	-	7/16-28 UNEF	.59 (15.0)			
-	-	-	09 A	-	M12 x 1 - 6H	.65 (16.5)	.86 (21.8)	.75 (19.1)	
08	-	-	-	-	1/2-20 UNF	.65 (16.5)			
-	-	-	-	08 9 A B	1/2-28 UNEF	.65 (16.5)			
03	10 11	-	-	-	9/16-24 UNEF	.72 (18.3)	.98 (24.9)	.88 (22.2)	
-	-	-	11 B	-	M15 x 1 - 6H	.77 (19.6)			
10	-	-	-	-	5/8-24 UNEF	.77 (19.6)			
-	-	-	-	10 11 C D	5/8-28 UN	.77 (19.6)			
-	12 13	-	-	-	11/16-24 UNEF	.84 (21.3)	1.16 (29.4)	1.00 (25.4)	
-	-	-	13 C	-	M18 x 1 - 6H	.89 (22.6)			
12 7	-	11 A	-	-	3/4-20 UNEF	.91 (23.1)			
-	-	-	-	12 13 F	3/4-28 UNS	.91 (23.1)			
-	14 15	-	-	-	13/16-20 UNEF	.97 (24.6)	1.28 (32.5)	1.13 (28.6)	
-	-	-	15 D	-	M22 x 1 - 6H	1.03 (26.2)			
14 12	-	13 B	-	-	7/8-20 UNEF	1.03 (26.2)			
-	-	-	-	14 15 G H	7/8-28 UN	1.03 (26.2)			
-	16 17	-	-	-	15/16-20 UNEF	1.09 (27.7)	1.41 (35.7)	1.25 (31.8)	
-	-	-	17 E	-	M25 x 1 - 6H	1.15 (29.2)			
16 19	-	15 C	-	-	1-20 UNEF	1.15 (29.2)			
-	-	-	-	16 17 J K	1-28 UN	1.15 (29.2)			
18 27	18 19	-	-	-	1-1/16-18 UNEF	1.22 (31.0)	1.52 (38.5)	1.38 (35.1)	
-	-	-	19 F	-	M28 x 1 - 6H	1.28 (32.5)			
-	-	-	17 D	-	1-1/8-18 UNEF	1.28 (32.5)			
-	-	-	-	18 19 M N	1-1/8-28 UN	1.28 (32.5)			
20 37	20 21	-	-	-	1-3/16-18 UNEF	1.34 (34.0)	1.64 (41.7)	1.50 (38.1)	
-	-	-	21 G	-	M31 x 1 - 6H	1.41 (35.8)			
-	-	19 E	-	-	1-1/4-18 UNEF	1.41 (35.8)			
-	-	-	-	20 21 P R	1-1/4-28 UN	1.41 (35.8)			
22	22 23	-	-	-	1-5/16-18 UNEF	1.47 (37.3)	1.77 (44.9)	1.63 (41.3)	
-	-	-	23 H	-	M34 x 1 - 6H	1.53 (38.9)			
-	-	-	-	22 23 S I	1-3/8-28 UN	1.53 (38.9)			
24	24 25	23 F	-	-	1-7/16-18 UNEF	1.59 (40.4)	1.89 (48.0)	1.75 (44.5)	
-	-	-	25 J	-	M37 x 1 - 6H	1.66 (42.2)			
61	-	-	-	-	1-1/2-18 UNEF	1.66 (42.2)			
-	-	-	-	24 25 U M	1-1/2-28 UN	1.66 (42.2)	2.02 (51.2)	1.88 (47.6)	
-	-	25 G	-	-	1-9/16-18 UNEF	1.66 (42.2)			
28	-	-	-	-	1-3/4-18 UNS	1.97 (50.0)	2.16 (54.8)	2.00 (50.8)	



## Connector Designator

# A

SPECIFICATION	SERIES
MIL-DTL-5015	MS34XX
MIL-DTL-26482	2
MIL-C-81703	3
MIL-DTL-83723	1 & 3
40M39569	NB
DEF 5326-3	
LN 29504	
NFC 93422	HE 302
PAN 6432-1	
PAN 6432-2	
PATT 602	
EN2997	



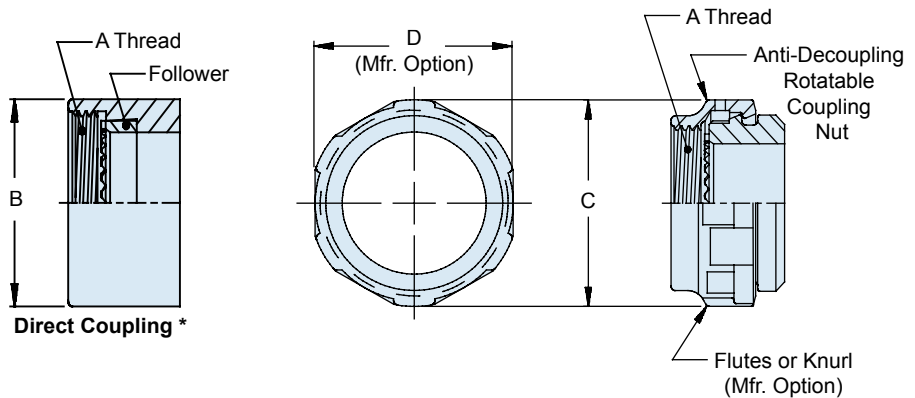
Note: Code A, rotatable coupling supplied without O-ring. Environmental seal performed by interface geometry.

\* Consult factory for direct coupling part numbers.

## Connector Designator

# F

SPECIFICATION	SERIES
MIL-DTL-38999	I & II
40M38277	NLS
NFC 93422	HE 309
NFC93422	HE 308
PAN 6433-1	
PATT 614	
PATT 616	



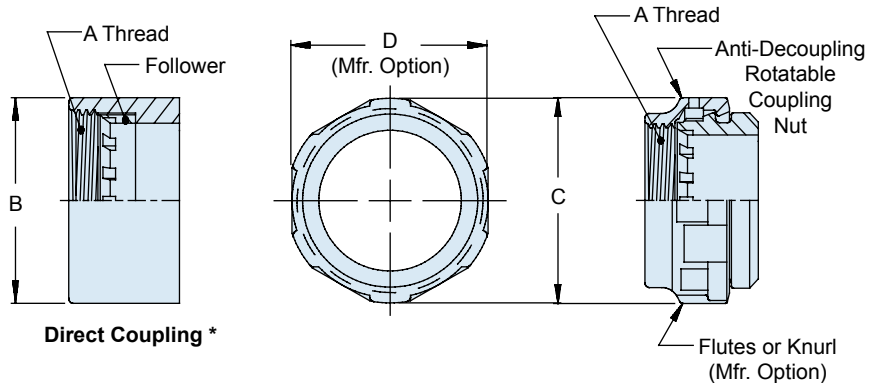
Note: Direct coupling supplied with O-ring for moisture sealing. Add modifier code 101A to end of part number for O-ring to be supplied on rotatable coupling.

\* Consult factory for direct coupling part numbers.

## Connector Designator

# G

SPECIFICATION
MIL-DTL-28840



Note: Code G, rotatable coupling is supplied without O-ring. Environmental seal performed by interface geometry.

\* Consult factory for direct coupling part numbers.

### Connector Designator

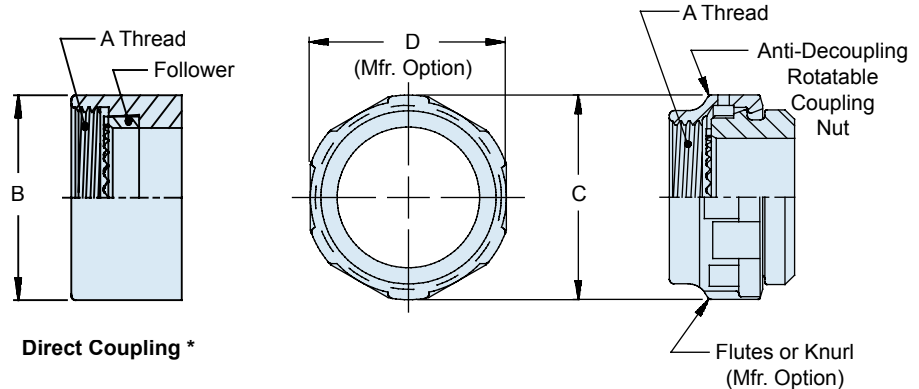
# H

#### SPECIFICATION

MIL-DTL-38999  
EN3645

#### SERIES

III & IV



Direct Coupling \*

Note: Direct coupling supplied with O-ring for moisture sealing. Add modifier code 101A to end of part number for O-ring to be supplied on rotatable coupling.

\* Consult factory for direct coupling part numbers.

### Connector Designator

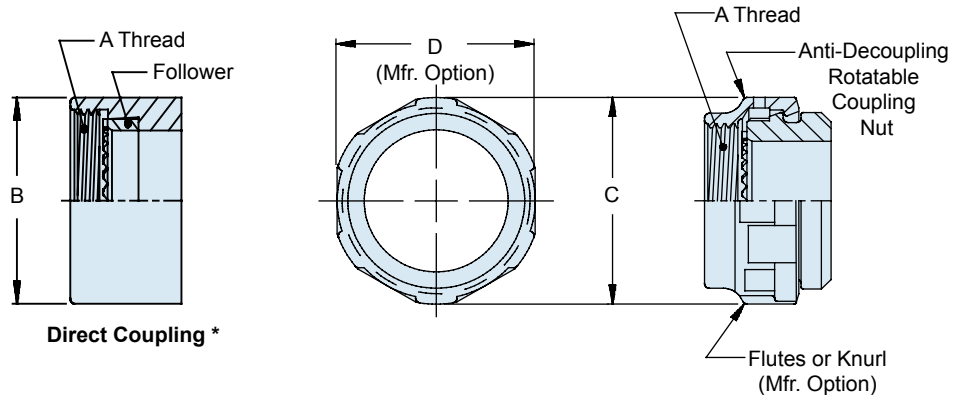
# L

#### SPECIFICATION

EN3372  
JN1003  
LN 29729  
NFC93422  
PAN 6433-2  
PATT  
615  
VG 96912

#### SERIES

HE306



Direct Coupling \*

Note: Direct coupling supplied with O-ring for moisture sealing. Add modifier code 101A to end of part number for O-ring to be supplied on rotatable coupling.

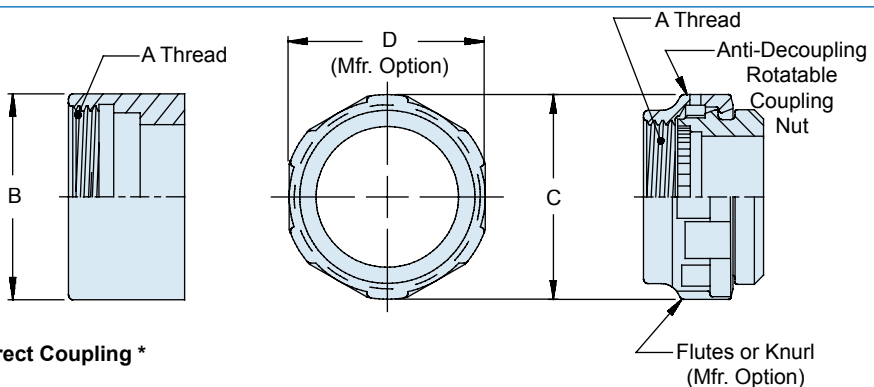
\* Consult factory for direct coupling part numbers.

### Connector Designator

# U

#### SPECIFICATION

MIL-C-29600



Direct Coupling \*

Note: Direct coupling supplied with O-ring for moisture sealing. Add modifier code 101A to end of part number for O-ring to be supplied on rotatable coupling.

\* Consult factory for direct coupling part numbers.

# Military Standard Connector Index

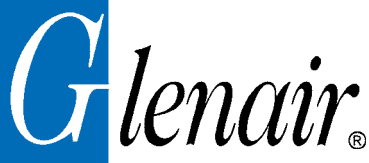


The following is a listing of circular connectors defined by US Military Specifications, cross-referenced to the applicable active or inactive part number series. The

symbols in the Connector Designator column are an essential element in Glenair's backshell part number developments.

PART NO.	CONN. DESIG.	SPECIFICATION	SERIES	DESCRIPTION
MS3400	A	MIL-DTL-5015	MS3400	Receptacle, Wall Mtg
MS3401	A	MIL-DTL-5015	MS3400	Receptacle, Cable Connecting
MS3404	A	MIL-DTL-5015	MS3400	Receptacle, Jam Nut
MS3406	A	MIL-DTL-5015	MS3400	Plug
MS3408	A	MIL-DTL-5015	MS3400	Plug, 90°
MS3409	A	MIL-DTL-5015	MS3400	Plug, 45°
MS3412	A	MIL-DTL-5015	MS3400	Receptacle, Wall Mtg
MS3424	A	MIL-C-81703	3	Receptacle, Push Pull, Wall Mtg
MS3446	A	MIL-C-81703	3	Plug, Rack & Panel
MS3450	A	MIL-DTL-5015	MS3450	Receptacle, Wall Mtg (was M83723/19/20)
MS3451	A	MIL-DTL-5015	MS3450	Receptacle, Cable Connecting (was M83723/17/18)
MS3454	A	MIL-DTL-5015	MS3450	Receptacle, Jam Nut
MS3456	A	MIL-DTL-5015	MS3450	Plug, Straight (was M83723/23/24)
MS3459	A	MIL-DTL-5015	MS3450	Plug, Straight, Self Locking (was M83723/52/53)
MS3464	A	MIL-C-81703	3	Receptacle, Push Pull, Jam Nut
MS3467	A	MIL-C-81703	3	Plug, Push Pull
MS3468	A	MIL-C-81703	3	Plug, Push Pull, Lanyard
MS3470	A	MIL-DTL-26482	2	Receptacle, Narrow Flange Mtg (was M83723/1/2)
MS3471	A	MIL-DTL-26482	2	Receptacle, Cable Connecting (was M83723/7/8)
MS3472	A	MIL-DTL-26482	2	Receptacle, Wide Flange Mtg (was M83723/3/4)
MS3474	A	MIL-DTL-26482	2	Receptacle, Rear Mtg, Jam Nut (was M83723/5/6)
MS3475	A	MIL-DTL-26482	2	Plug, RFI Shielded (was M83723/42/43)
MS3476	A	MIL-DTL-26482	2	Plug, Straight (was M83723/13/14)
MS27466	F	MIL-DTL-38999	I	Receptacle, Wall Mtg
MS27467	F	MIL-DTL-38999	I	Plug, Straight
MS27468	F	MIL-DTL-38999	I	Receptacle, Jam Nut
MS27472	F	MIL-DTL-38999	II	Receptacle, Wall Mtg
MS27473	F	MIL-DTL-38999	II	Plug, Straight
MS27474	F	MIL-DTL-38999	II	Receptacle, Jam Nut
MS27475	F	MIL-DTL-38999	II	Receptacle, Wall Mtg
MS27479	F	MIL-DTL-38999	II	Inactive Use MS27472
MS27480	F	MIL-DTL-38999	II	Inactive Use MS27473
MS27481	F	MIL-DTL-38999	II	Inactive Use MS27474
MS27482	F	MIL-DTL-38999	II	Inactive Use MS27475
MS27484T	F	MIL-DTL-38999	II	Plug, Straight
MS27497	F	MIL-DTL-38999	II	Receptacle, Back Panel Wall Mtg
MS27498	F	MIL-DTL-38999	I	Plug, 90°
MS27500	F	MIL-DTL-38999	II	Inactive See MS27473
MS27515	F	MIL-DTL-38999	I	Inactive Use MS27656

\* Consult factory



## Military Standard Connector Index

PART NO.	CONN. DESIG.	SPECIFICATION	SERIES	DESCRIPTION
MS27652	F	MIL-DTL-38999	I	Inactive Use MS27466
MS27653	F	MIL-DTL-38999	I	Inactive Use MS27467
MS27654	F	MIL-DTL-38999	I	Inactive Use MS27656
MS27656	F	MIL-DTL-38999	I	Receptacle, Back Panel, Wall Mtg
MS27661	F-752	MIL-DTL-38999	I	Plug, Lanyard Release
MS27665	F	MIL-DTL-38999	I	Plug, Rack & Panel Mtg
M28840/10	G	MIL-DTL-28840		Receptacle, Wall Mtg
M28840/11	G	MIL-DTL-28840		Receptacle, Cable Connecting
M28840/14	G	MIL-DTL-28840		Receptacle, Jam Nut
M28840/16	G	MIL-DTL-28840		Plug, Straight
D38999/20	H	MIL-DTL-38999	III	Receptacle, Wall Mtg
D38999/24	H	MIL-DTL-38999	III	Receptacle, Jam Nut
D38999/26	H	MIL-DTL-38999	III	Plug, Straight
D38999/29	H-701	MIL-DTL-38999	III	Plug, Lanyard Release
D38999/30	H-701	MIL-DTL-38999	III	Plug, Lanyard Release
D38999/40	H	MIL-DTL-38999	IV	Receptacle, Wall Mtg
D38999/42	H	MIL-DTL-38999	IV	Receptacle, Box Mtg
D38999/44	H-715	MIL-DTL-38999	IV	Receptacle, Jam Nut
D38999/46	H	MIL-DTL-38999	IV	Plug, Straight, EMI
D38999/47	H	MIL-DTL-38999	IV	Plug, Straight
M83723/1	A	MIL-DTL-83723	I	Superseded by MS3470
M83723/2	A	MIL-DTL-83723	I	Superseded by MS3470
M83723/3	A	MIL-DTL-83723	I	Superseded by MS3472
M83723/4	A	MIL-DTL-83723	I	Superseded by MS3472
M83723/5	A	MIL-DTL-83723	I	Superseded by MS3474
M83723/6	A	MIL-DTL-83723	I	Superseded by MS3474
M83723/7	A	MIL-DTL-83723	I	Superseded by MS3471
M83723/8	A	MIL-DTL-83723	I	Superseded by MS3471
M83723/13	A	MIL-DTL-83723	I	Superseded by MS3476
M83723/14	A	MIL-DTL-83723	I	Superseded by MS3476
M83723/36	A	MIL-DTL-83723	I	Inactive For New Design
M83723/37	A	MIL-DTL-83723	I	Inactive For New Design
M83723/38	A	MIL-DTL-83723	I	Inactive For New Design
M83723/39	A	MIL-DTL-83723	I	Inactive For New Design
M83723/40	A	MIL-DTL-83723	I	Inactive For New Design
M83723/41	A	MIL-DTL-83723	I	Inactive For New Design
M83723/42	A	MIL-DTL-83723	I	Superseded by MS3475
M83723/43	A	MIL-DTL-83723	I	Superseded by MS3475
M83723/48	A	MIL-DTL-83723	I	Inactive For New Design
M83723/49	A	MIL-DTL-83723	I	Inactive For New Design
M83723/66	A	MIL-DTL-83723	III	Plug, Push Pull (Pin Contacts)
M83723/67	A	MIL-DTL-83723	III	Plug, Push Pull (Socket Contacts)
M83723/68	A	MIL-DTL-83723	III	Plug, Push Pull Lanyard, (Pin Contacts)
M83723/69	A	MIL-DTL-83723	III	Plug, Push Pull, Lanyard, (Socket Contacts)
M83723/71	A	MIL-DTL-83723	III	Receptacle, Bayonet, Flange Mtg, (Socket Contact)
M83723/72	A	MIL-DTL-83723	III	Receptacle, Bayonet, Flange Mtg, (Pin Contact)
M83723/73	A	MIL-DTL-83723	III	Receptacle, Bayonet, Single Hole Mtg, (Socket Contact)

\* Consult factory

# Military Standard Connector Index



PART NO.	CONN. DESIG.	SPECIFICATION	SERIES	DESCRIPTION
M83723/74	A	MIL-DTL-83723	III	Receptacle, Bayonet Single Mtg, (Pin Contact)
M83723/75	A	MIL-DTL-83723	III	Plug, Bayonet (Socket Contact)
M83723/76	A	MIL-DTL-83723	III	Plug, Bayonet (Pin Contact)
M83723/77	A	MIL-DTL-83723	III	Plug, Bayonet, RFI (Socket Contact)
M83723/78	A	MIL-DTL-83723	III	Plug, Bayonet, RFI (Pin Contact)
M83723/82	A	MIL-DTL-83723	III	Receptacle, Threaded, Flange Mtg, (Socket Contact)
M83723/83	A	MIL-DTL-83723	III	Receptacle, Threaded, Flange Mtg, (Pin Contact)
M83723/84	A	MIL-DTL-83723	III	Receptacle, Threaded Single Hole Mtg, (Socket Contact)
M83723/85	A	MIL-DTL-83723	III	Receptacle, Threaded Single Hole Mtg, (Pin Contact)
M83723/86	A	MIL-DTL-83723	III	Plug, Threaded, (Socket Contact)
M83723/87	A	MIL-DTL-83723	III	Plug, Threaded, (Pin Contact)
M83723/91	A	MIL-DTL-83723	III	Plug, Threaded, RFI (Socket Contact)
M83723/92	A	MIL-DTL-83723	III	Plug, Threaded, RFI (Pin Contact)
M83723/95	A	MIL-DTL-83723	III	Plug, Threaded, (Socket Contact), Self Locking
M83723/96	A	MIL-DTL-83723	III	Plug, Threaded, (Pin Contact), Self Locking
M83723/97	A	MIL-DTL-83723	III	Plug, Threaded, RFI (Socket Contact), Self Locking
M83723/98	A	MIL-DTL-83723	III	Plug, Threaded, RFI (Pin Contact), Self Locking
NATC00	H*	SSQ21635		Receptacle, Flange
NATC06	H*	SSQ21635		Plug
NATC07	H*	SSQ21635		Receptacle, Jam Nut
NBO	A	40M39569		Receptacle, Flange Mtg
NB4	A	40M39569		Receptacle, Flange Mtg
NB6	A	40M39569		Plug, Straight
NB6G	A	40M39569		Plug, Straight, EMI
NB7	A	40M39569		Receptacle, Jam Nut
NLSO	F	40M38277		Receptacle, Flange Mtg
NLS6	F	40M38277		Plug, Straight
NLS6G	F	40M38277		Plug, Straight, EMI
NLS7	F	40M38277		Receptacle, Jam Nut
NZGL00	H**	SSQ21635		Receptacle, Flange
NZGL06	H**	SSQ21635		Plug
NZGL07	H**	SSQ21635		Receptacle, Weld Mtg
NZGL66	H**	SSQ21635		Plug

\* Consult factory

H\* NATC Series size 09 through 25 mates to Glenair Connector Designator H, consult factory for sizes 33 & 37

H\*\* NZGL Series requires special accessories manufactured by Glenair, consult factory



## Connector-Backshell Interface Index

These lists of specifications, associated connector manufacturer part numbers, and common rear accessory interface designators DO NOT imply qualification status of the manufacturers indicated for each specification series. The listings are only for the identification of

common interface data under the applicable Connector Designator symbol, an essential element used in Glenair's accessory part number development. For connector manufacturer part number series not shown, please consult factory.

CONN. DESIG.	SPECIFICATION	CONNECTOR MANUFACTURER	MANUFACTURER SERIES
<b>A</b>	MIL-DTL-5015	Aero-Electric Connector	AE55
	MS3400	Flight Connector	FF
	MS3450	Glenair	IT / ITS
		J-Tech	JT 3400 / JT3450
		ITT Cannon	CV340 / CV345
	MIL-DTL-26482 Series II	Aero-Electric Connector	AE77
		Amphenol	PTS-DR / 91-483 / 118
		Deutsch ECD	AFD5
		FCI	8526
		Glenair	IPT
		ITT Cannon	PV7
	MIL-C-81703 Series III	Deutsch ECD	DBA5 / D817
	MIL-DTL-83723 Series I	Amphenol	PTS-DR / 01-483 / 118
		ITT Cannon	PVA
		ITT Cannon UK Limited	PV-S
	Deutsch ECD	AFD	
MIL-DTL-83723 Series III	Amphenol Products	518	
	Amphenol/Pyle National	B	
	Deutsch ECD	DL6 / 837	
	FCI	83723	
	ITT Cannon	MF	
	Labinal/Cinch	CN0930	
40M39569	Deutsch ECD	DBA / 381	
	ITT Cannon	PV-G	
CECC 75201.001	FCI		
DEF 5326-3	Amphenol-Tuchel	602GB	
ESC 10	Amphenol/Pyle National		
	Compagnie Deutsch		
	FCI		
	Hi-Rel Connectors Inc.		
	ITT Cannon UK Limited		
	Sealtron Inc.		
ESC 11	Amphenol/Pyle National		
	Compagnie Deutsch		
LN 29504	Amphenol Limited	118 / 652	
	Amphenol-Tuchel	118 / 652	
	Compagnie Deutsch	AFD / DFE / FDBA	
	FCI	8525.1	
	ITT Cannon UK Ltd.	PVW	
	ITT Cannon Electric GmbH	PVW	

## Connector-Backshell Interface Index



CONN. DESIG.	SPECIFICATION	CONNECTOR MANUFACTURER	MANUFACTURER SERIES
<b>A</b>	NFC93422 / HE302 PAN 6432-1	FCI	8525
		Amphenol Limited	602GB
	PAN 6432-2	Amphenol-Tuchel	602GB
		ITT Cannon UK Ltd.	PVX
		ITT Cannon Electric GmbH	PVX
		Compagnie Deutsch	AFD
	PATT 602	Deutsch Ltd	RR
		FCI	8526
		ITT Cannon UK Ltd.	PVX
		VG 95328	Cie Deutsch
	VG 95328	Compagnie Deutsch	DVG / 951-50
		Glenair	IPT, IPT-SE
<b>F</b>	MIL-DTL-38999 Series I	Aero-Electric Connectors	AE46 / AE49
		Amphenol	LJT-R / 418-1
		FCI	8LT
		Glenair	231
		ITT Cannon	KJL
	MIL-DTL-38999 Series II	AB Electronics	CT-R
		Aero-Electric Connectors	AE47 / AE48
		Amphenol	JT-R / 418-2
		FCI	8T
		Glenair	232
	40M38277	ITT Cannon	KJ
		Amphenol	JT-R / 10-475
	NFC 93422 HE308	ITT Cannon	KJ
		FCI	8LT
	NFC 93422 HE309	ITT Cannon Electric France	KJL
		FCI	8T
	PAN 6433-1	ITT Cannon Electric France	KJ
		Amphenol Limited	JT / JTP
		AB Electronics	CT
		FCI	8T
		ITT Cannon Electric France	KJ
		ITT Cannon UK Ltd.	KJ
		ITT Cannon Electric GmbH	KJ
	PATT 614	TEC	TT / TTPQ
		Amphenol Limited	418-2
		FCI	8T
		ITT Cannon UK Ltd.	KJ
	PATT 614	TEC	TT

CONN. DESIG.	SPECIFICATION	CONNECTOR MANUFACTURER	MANUFACTURER SERIES
<b>F</b>	PATT 616	Amphenol Limited	418-1
		FCI	8LT
		ITT Cannon UK Ltd.	KJL
<b>G</b>	MIL-DTL-28840	Glenair	90
		G & H Technology	NC
		Hughes Connecting Devices	GTA
		ITT Cannon	KFS
		Sunbank	JSC
<b>H</b>	MIL-DTL-38999 Series III	Aero-Electric Connector	AE22
		Amphenol	TV-R / TVS / TVS-R
		Amphenol/Pyle National	T3
		Deutsch ECD	DTS
		Glenair	233
	MIL-DTL-38999 Series IV	ITT Cannon	KJADIV4
		Deutsch ECD	PL
		Flight Connector	BL
	CECC 75201.002	G & H Technology	CNO
		Glenair	234
<b>L</b>	JN 1003	FCI	JVS
		Amphenol	TVRB
		Amphenol Limited	SJT
		Deutsch Limited	HDJ
		FCI	8ST
	LN 29729	TEC	STT
		Amphenol Limited	SJT
		FCI	8ST
	NFC 93422, HE 306	ITT Cannon Electric GmbH	CGK
		FCI	8ST
	PAN 6433-2	Amphenol Limited	SJT
		FCI	8ST
		TEC	STT
	PATT 615	Amphenol Limited	SJT
		FCI	8ST
TEC		STT	
VG 96912	Amphenol Limited	SJT	
	ITT Cannon Electric GmbH	CGK	
	FCI	8ST	
	TEC	STT	
<b>U</b>	MIL-C-29600 Series A	Deutsch Limited	DG123
			DG123A



# Connector Manufacturers Reference



This index of USA and international connector manufacturers provides a cross-reference of manufacturers' proprietary series designations to applicable specifications. This information does not imply qualification status but serves to indicate that the manufacturers' series is "in conformance with" the noted

specifications or documents. The symbols in the Connector Designator column are an essential element in Glenair's accessory part number developments. For connector manufacturers' part number series not shown in these listings, please consult factory for applicable accessory part numbers.

MFG SERIES	CONN. DESIG.	SPECIFICATION REFERENCE	SERIES
<b>Aero-Electric Connector Company</b>			
AE22	H	MIL-DTL-38999	III
AE46	F	MIL-DTL-38999	I
AE47	F	MIL-DTL-38999	II
AE48	F	MIL-DTL-38999	II
AE49	F	MIL-DTL-38999	I
AE77	A	MIL-DTL-26482	II
AE83	A	MIL-DTL-83723	III
<b>AB Electronics</b>			
CT-R	F	MIL-DTL-38999	II
<b>Amphenol Limited</b>			
JT	F	PAN 6433-1	
SJT	L	JN 1003	
SJT	L	LN29729	
SJT	L	PAN 6433-2	
118	A	LN 29504	
418-1	F	PATT 616	
418-2	F	PATT 614	
418-5	L	NFC 93422	HE 306
418-5	L	PATT 615	
602GB	A	PAN 6432-1	
602GB	A	PATT 602	
652	A	LN 29504	
<b>Amphenol Products</b>			
JT	*	MIL-DTL-27599	
JT-R	F	MIL-DTL-38999	II
JT-R	F	40M38277	
LJT	*	MIL-DTL-27599	
LJT-R	F	MIL-DTL-38999	I
PTS-DR	A	MIL-DTL-26482	II
PTS-DR	A	MIL-DTL-83723	I
SJT	L	LN 29729	
TV	H	MIL-DTL-38999	III
TVRB	H	CECC 75201.002	III
TVS	H	MIL-DTL-38999	III
10-475	F	40M38277	
118	A	MIL-DTL-26482	II
118	A	MIL-DTL-83723	I
246	*	MIL-DTL-5015	
418-1	F	MIL-DTL-38999	I

MFG SERIES	CONN. DESIG.	SPECIFICATION REFERENCE	SERIES
<b>Amphenol Products (Continued)</b>			
418-2	F	MIL-DTL-38999	II
518	A	MIL-DTL-83723	III
91-483	A	MIL-DTL-26482	II
91-483	A	MIL-DTL-83723	I
<b>Amphenol/Pyle National</b>			
B	A	MIL-DTL-83723	III
T3	H	MIL-DTL-38999	III
	A	ESC 10, ESC 11	
<b>Amphenol/Tuchel Electronics GmbH</b>			
118	A	LN 29504	
162GB	*	VG 95328	
602GB	A	DEF 5326-3	
602GB	A	PAN 6432-1	
602GB	A	PATT 602	
62GB	*	DEF 5326-3	
652	A	LN 29504	
<b>Cie Deutsch &amp; Compagnie Deutsch GmbH</b>			
AFD	A	LN 29504	
AFD	A	MIL-DTL-26482	I
AFD	A	PAN 6432-1	
DBAS	A	MIL-C-81703	III
DBAS	A	PAN 6432-2	
DFE	A	LN 29504	
DVG	A	VG 95328	
FDBA	A	LN 29504	
951	A	PRL 53125	
9.815	J	MIL-C-81511	III & IV
991	A	PAN 6432-4	
999.1	F	MIL-DTL-38999	I
	A	ESC 10	
	A	ESC 11	
<b>Deutsch Engineered Connecting Devices</b>			
AFD5	A	MIL-DTL-26482	II
AFD	A	MIL-DTL-83723	I
A815	J	MIL-C-81511	III
B815	J	MIL-C-81511	IV
BMS	E	MIL-DTL-26500	

\* Consult factory for backshell part numbers.

MFG SERIES	CONN. DESIG.	SPECIFICATION REFERENCE	SERIES
<b>Cie Deutsch &amp; Compagnie Deutsch GmbH (Continued)</b>			
DFE	A	LN 29504	
DVG	A	VG 95328	
FDBA	A	LN 29504	
951	A	PRL 53125	
9.815	J	MIL-C-81511	III & IV
991	A	PAN 6432-4	
999.1	F	MIL-DTL-38999	I
	A	ESC 10	
	A	ESC 11	
<b>Deutsch Engineered Connecting Devices</b>			
AFD5	A	MIL-DTL-26482	II
AFD	A	MIL-DTL-83723	I
A815	J	MIL-C-81511	III
B815	J	MIL-C-81511	IV
BMS	E	MIL-DTL-26500	
BTK	D	MIL-DTL-26482	I
DBA	A	40M39569	
DBA7	A	MIL-C-81703	III
DTS	H	MIL-DTL-38999	III
DIV4	H	MIL-DTL-38999	IV
DL6	A	MIL-DTL-83723	III
D817	A	MIL-C-81703	III
LPT	D	MIL-DTL-26482	I
381	A	40M39569	
450	D	MIL-DTL-26482	I
460	D	MIL-DTL-26482	I
837	A	MIL-DTL-83723	III
<b>Deutsch Limited</b>			
LL	J	MIL-C-81511	III-IV
DBAS	A	PAN 6432-2	
DTS	H	MIL-DTL-38999	III
HDJ	L	JN 1003	
RR	A	PAN 6432-1	
RR	A	PATT 602	
RR70	A	MIL-C-81703	III
SLPT	*	MIL-DTL-26482	I
DG123	U	MIL-C-29600	A
DG123A	U	MIL-C-29600	A

MFG SERIES	CONN. DESIG.	SPECIFICATION REFERENCE	SERIES
<b>FCI/Burndy Corporation</b>			
BT	D	MIL-DTL-26482	I
G	D	MIL-DTL-26482	I
L	D	MIL-DTL-26482	I
L-T	D	MIL-DTL-26482	I
M-T	D	MIL-DTL-26482	I
<b>FCI</b>			
JVS	H	CECC 75201.002	
8LT	F	MIL-DTL-38999	I
8LT	F	NFC 93422	HE 308
8ST	L	JN 1003	
8ST	L	LN 29729	
8ST	L	NFC 93422	HE 306
8ST	L	PAN 6433-2	
8ST	L	PATT 615	
8ST	L	VG 96912	
8T	F	MIL-DTL-38999	II
8T	F	NFC 93422	HE 309
83723	A	MIL-DTL-83723	III
85	D	MIL-DTL-26482	I
851	S	PATT 603	
851-50	*	PRL 53125	
851-50	*	VG 95328	
8525	A	NFC 93422	HE 302
8525.1	A	LN 29504	
8526	A	MIL-DTL-26482	II
8526	A	PAN 6432-1	
8526	A	PATT 602	
8533	A	EN 2992	
8533	A	ESC 10	
<b>Flight Connector Corporation</b>			
FC	*	MIL-DTL-5015	
FF	A	MIL-DTL-5015	MS3400
FH	*	MIL-DTL-5015	
FHA	K	MIL-DTL-83723	II
PL	H	MIL-DTL-38999	IV
<b>G &amp; H Technologies</b>			
BL	H	MIL-DTL-38999	IV
NC	G	MIL-DTL-28840	

\* Consult factory for backshell part numbers.



MFG SERIES	CONN. DESIG.	SPECIFICATION REFERENCE	SERIES
<b>Glenair</b>			
IPT	A	MIL-DTL-26482	
231, 232	F	MIL-DTL-38999	I, II
233, 234	H	MIL-DTL-38999	III, IV
90	G	MIL-DTL-28840	
IT, ITS	A	MIL-DTL-5015	
<b>ITT Cannon</b>			
CA3106B	*	VG95234	
CV340	A	MIL-DTL-5015	MS3400
CV345	A	MIL-DTL-5015	MS3450
KFS	G	MIL-DTL-28840	
KJ	F	MIL-DTL-38999	II
KJ	F	40M38277	
KJA	H	MIL-DTL-38999	III
KJL	F	MIL-DTL-38999	I
MF	A	MIL-DTL-83723	III
PV-G	A	40M39569	
PVA	A	MIL-DTL-83723	I
PV7	A	MIL-DTL-26482	II
	A	ESC 10	KE, SE
<b>ITT Cannon Electric France SA</b>			
KJ	F	MIL-DTL-38999	II
KJ	F	PAN 6433-1	
KJL	F	MIL-DTL-38999	I
251	*	MIL-DTL-26482	I
<b>ITT Cannon UK Ltd.</b>			
KJ	F	PATT 614	
PV-S	A	MIL-DTL-83723	I
PVW	A	LN29504	
PVX	A	PAN 6432-1	
PVX	A	PATT 602	
	A	ESC 10	KE, SE
<b>ITT Cannon Electric GmbH</b>			
CA3106B	*	VG 95234	
CGK	L	LN 29729	
KJ	F	PAN 6433-1	
KPSE	*	VG 95328	
KPT	*	VG 95328	
PVW	A	LN 29504	
PVX	A	PAN 6432-1	

MFG SERIES	CONN. DESIG.	SPECIFICATION REFERENCE	SERIES
<b>J-Tech</b>			
JT 3400	A	MIL-DTL-5015	MS3400
JT 3450	A	MIL-DTL-5015	MS3450
JTVG95234	A	VG95234	
JT 3400	A	MIL-DTL-5015	MS3400
JT 3450	A	MIL-DTL-5015	MS3450
JTVG95234	A	VG95234	
<b>Labinal/Cinch</b>			
CNO930	A	MIL-DTL-83723	III
<b>RMS</b>			
RO		MIL-DTL-26500	Aluminum
<b>Schaltbau GmbH</b>			
674	*	VG 95328	
675	*	VG 95328	
<b>SICEM</b>			
SCB	*	VG 95234	
<b>Sunbank</b>			
JSC		MIL-DTL-28840	
<b>TEC</b>			
TT	F	PAN 6433-1	
STT	L	LN 29729	
STT	L	PAN 6433-2	
STT	L	PATT 615	
STT	L	VG 96912	
<b>VEAM Litton Precision Products International</b>			
CIR	*	VG 95234	
VPT-SE	*	MIL-DTL-26482	I
VPT-SE	*	VG 95328	

\* Consult factory for backshell part numbers.



## Connector Manufacturers Alpha-Numeric Index

The following alpha-numeric list is provided as a convenience in identifying the various connector manufacturers' proprietary connector series designations applicable to the US and international

specifications and documents listed previously. The Glenair Connector Designator is also indicated for each listing. For complete manufacturer's identity, refer to the preceding Connector Manufacturers Index.

MFG SERIES	CONN. DESIG.	CONNECTOR MANUFACTURER
AE22	H	Aero-Electric Connector
AE46	F	Aero-Electric Connector
AE47	F	Aero-Electric Connector
AE48	F	Aero-Electric Connector
AE49	F	Aero-Electric Connector
AE55	A	Aero-Electric Connector
AE66	E	Aero-Electric Connector
AE77	A	Aero-Electric Connector
AFD	A	Compagnie Deutsch
AFD	A	Deutsch ECD
AFD5	A	Deutsch ECD
A815J	J	Deutsch ECD
B	A	Pyle-National
BG	D	Amphenol
BL	H	G & H Technology
BT	D	FCI
BTK	D	Deutsch ECD
B815	J	Deutsch ECD
CA3106B	*	Cannon Electric GmbH
CA-E/R	B	ITT Cannon
CA-RX	B	ITT Cannon
CGK	L	ITT Cannon Electric GmbH
CIR	*	VEAM
CNO	H	Labinal
CNO930	A	Labinal
CT-R	F	Plessey Connectors
CVA	K	ITT Cannon
CV340	A	ITT Cannon
CV345	A	ITT Cannon
CWLD	C	ITT Cannon Electric GmbH
DBA	A	Deutsch ECD
DBAS	A	Compagnie Deutsch
DBAS	A	Cie Deutsch
DBAS	A	Deutsch ECD
DFE	A	Cie Deutsch
DIV4	H	Deutsch ECD
DL6	A	Deutsch ECD
DTS	H	Cie Deutsch
DVG	A	Cie Deutsch
D817	A	Deutsch ECD
FC	*	Elecsys

MFG SERIES	CONN. DESIG.	CONNECTOR MANUFACTURER
FDBA	A	Compagnie Deutsch
FDBA	A	Deutsch
FF	A	Elecsys
FH	*	Elecsys
FHA	K	Elecsys
G	D	FCI
GTA	G	Hughes Connecting Devices
JT 3400	A	J-Tech
JT 3450	A	J-Tech
JT VG	*	J-Tech
JT	F	Amphenol
JT-R	F	Amphenol
JVS	H	FCI
TT	F	FKI
KFS	G	ITT Cannon
KJ	F	ITT Cannon UK Ltd.
KJ	F	ITT Cannon Electric France
KJ	F	ITT Cannon Electric GmbH
KJ	F	ITT Cannon
KJA	H	ITT Cannon
KJL	F	ITT Cannon Electric France
KJL	F	ITT Cannon
KPSE	S	ITT Cannon UK Ltd.
KPSE	D	ITT Cannon
KPT	*	ITT Cannon Electric GmbH
KPT	D	ITT Cannon
KPTM	*	ITT Cannon Electric GmbH
L	D	FCI
L-T	D	FCI
LJT	F	Amphenol
LJT-R	F	Amphenol
LL	J	Deutsch
LPT	D	Deutsch ECD
M-T	D	FCI
MF	A	ITT Cannon
MF-S	D	Amphenol Products
MK 8	S	AB Electronics
MK 12	S	AB Electronics
MK 18	S	AB Electronics
NC	G	G & H Technology
PL	H	Elecsys

\* Consult factory for backshell part numbers.

## Connector Manufacturers Alpha-Numeric Index



MFG SERIES	CONN. DESIG.	CONNECTOR MANUFACTURER
PTS-DR	A	Amphenol
PV-G	A	ITT Cannon
PV-S	A	ITT Cannon UK Ltd.
PVA	A	ITT Cannon
PVW	A	ITT Cannon UK Ltd.
PVW	A	ITT Cannon Electric GmbH
PVX	A	ITT Cannon UK Ltd.
PVX	A	ITT Cannon Electric GmbH
PV7	A	ITT Cannon
RDN	G	Elecsys
RR	A	Hellerman Deutsch
RR50	A	Cie Deutsch
RR70	A	Deutsch Ltd.
SCB	*	SICEM
SJT	L	Amphenol
STT	L	TEC
SLPT	*	Deutsch Ltd.
TV	H	Amphenol
TVS	H	Amphenol
T3	H	Pyle-National
VPT	D	VEAM
VPTE-SE	*	VEAM
10-214	B	Amphenol
10-475	F	Amphenol
118	A	Amphenol Limited
118	A	Amphenol
118	A	Amphenol-Tuchel
162GB	*	Amphenol-Tuchel
246	*	Amphenol
251	*	Cannon Electric France

MFG SERIES	CONN. DESIG.	CONNECTOR MANUFACTURER
381	A	Deutsch ECD
418-1	F	Amphenol Limited
418-1	F	Amphenol
418-2	F	Amphenol Limited
418-2	F	Amphenol
518	A	Amphenol
602GB	A	Amphenol Limited
602GB	A	Amphenol-Tuchel
62GB	*	Amphenol-Tuchel
652	A	Amphenol Limited
652	A	Amphenol-Tuchel
674	*	Schaltbau
675	*	Schaltbau
837	A	Deutsch ECD
83723	A	FCI
851-50	*	FCI
8525	A	FCI
8525.1	A	FCI
8526	A	FCI
857	A	FCI
8D	H	FCI
8LT	F	FCI
8ST	L	FCI
8T	F	FCI
9-815	J	Cie Deutsch
9-815	J	Compagnie Deutsch
91-483	A	Amphenol
951-50	A	Cie Deutsch
951-50	A	Compagnie Deutsch
991	A	Cie Deutsch
999.1	F	Cie Deutsch

\* Consult factory for backshell part numbers.



## Shield Termination Styles for Glenair Composite EMI/RFI Backshells

### RFI/EMI Backshell Shield Termination Styles

Conductive composite backshells are designed to terminate cable shielding and provide a low electrical resistant ground path. Various shield termination styles are available to match the electrical requirements of different application environments. All Glenair shield termination styles meet the shell conductivity requirements of AS85049. Standard self-locking as well as G-Load coupling styles are available for selected styles.

EMI/RFI Shield Termination Information					
Glenair Basic Part Number	Shield Termination Style	Shield Type			Page
		Overall	Individual	Combination	
311-019	Lamp Base Thread	X			A-6
311-034		X			A-5
319-134	Shield Sock Assemblies and Swing Arms	X	X	X	A-16
319-120		X	X	X	A-14
319-137		X	X	X	A-22
319-138		X	X	X	A-24
319-064		X	X	X	A-12
380-099		X	X		A-46
380-100		X	X		A-48
380-130	Cone and Ring and Knit Braid Style		X		A-52
380-131			X		A-53
380-132			X		A-54
387-083		X	X	X	A-58
390-052		X			A-62
440-087		X			A-64
440-143		X	X		A-68
440-144	X	X		A-70	
447-325	Banding and Crimp-Ring Style	X	X		A-72
447-326		X	X		A-74
447-327		X	X		A-76
447-711			X		A-87
447-331		X	X	X	A-84
507-088		X	X		A-92
557-186		X	X		A-94
447-328	Band-In-a-Can	X	X		A-78
447-657		X	X		A-86
447-329		X	X		A-80
447-330		X	X		A-82

## Reduced Weight and Zero Corrosion for Harsh Environment Interconnect Applications

**Hundreds of Military Standard and Commercial Connector Accessories Tooled, Stocked and Ready for Shipment.**

A

Composite connector accessories offer a wide range of benefits to the interconnect engineer, including corrosion resistance, vibration dampening, weight reduction and the reduction of magnetic signatures—a critical requirement in stealth applications.

Glenair composite connector accessories are ideally suited for use in harsh environments where resistance to high temperatures, outgassing, corrosive

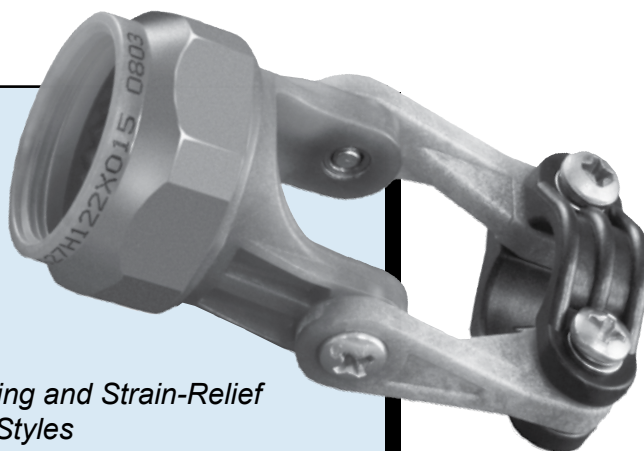
fluids, fire, shock and vibration is required. Materials include Ultem® 2300 and other glass filled composite thermoplastics. Glenair composite accessories are ASTM E595 space rated, and are qualified to the shock, vibration, thread strength and bend moment requirements of MIL-DTL-38999 and AS85049. These materials also meet stringent EMI/RFI/HIRF and indirect lightning strike performance specifications.

*Backshells Available to Fit Virtually All Military Standard and Commercial Connectors*

*Lightweight Components Withstand Shock, Temperature Cycling and Vibration*

*Conductive EMC Surface Finishes Including: Selectively Plated and RoHS Compliant Styles*

*EMI/RFI Shield Termination, Environmental Sealing and Strain-Relief Backshells for All Popular Connector Types and Styles*



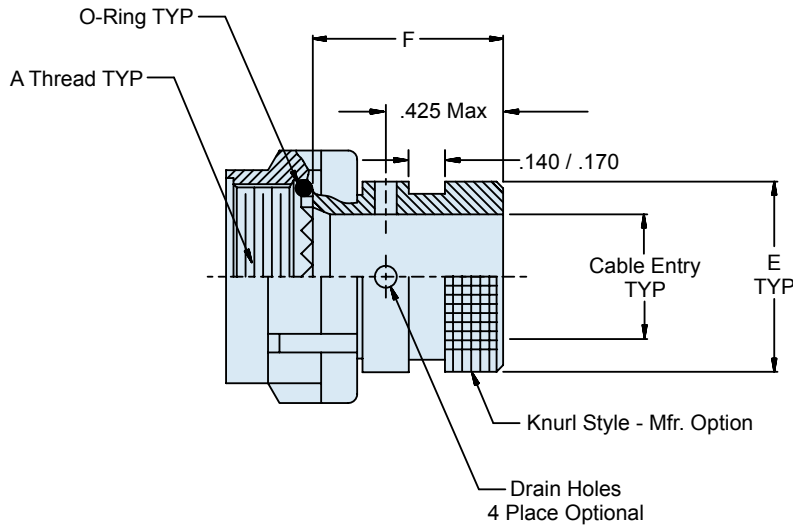
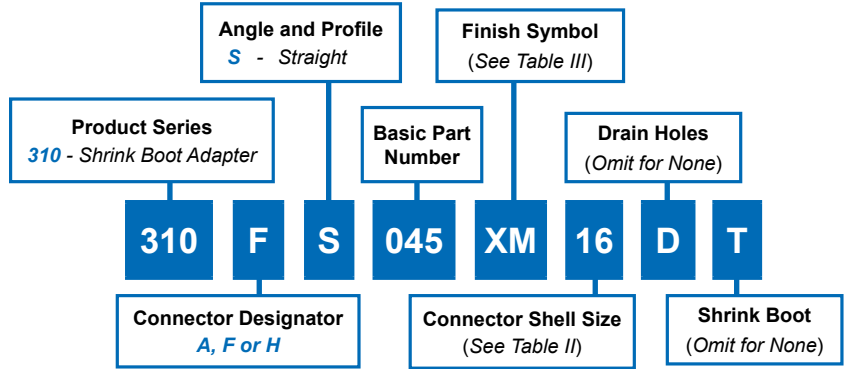
### Errata

Catalog contents—including part numbers, materials and dimensions—are accurate to the best of our ability when we go to print. Even so, customers are advised to consult the factory for the latest specifications, particularly to confirm critical dimensions such as connector lengths, threads, and so on. When errors or mistakes are brought to our attention, corrected content is posted immediately to our website: [www.glenair.com](http://www.glenair.com).

# 310-045 Composite Shrink Boot Adapter with Self-Locking Rotatable Coupling Nut

**A**

CONNECTOR DESIGNATOR:	
<b>A</b>	MIL-DTL-5015, -26482 Series II, and -83723 Series I and III
<b>F</b>	MIL-DTL-38999 Series I, II
<b>H</b>	MIL-DTL-38999 Series III and IV
<b>SELF-LOCKING</b>	
<b>ROTATABLE COUPLING</b>	
<b>STANDARD PROFILE</b>	





**310-045**  
**Composite Shrink Boot Adapter**  
**with Self-Locking Rotatable Coupling Nut**



**TABLE II: SHELL SIZE**

Shell Size		E Max	F Max	Cable Entry Min.
A, F	H			
08	09	.533 (13.5)	.940 (23.9)	.250 (6.4)
10	11	.605 (15.4)	.940 (23.9)	.355 (9.0)
12	13	.774 (19.7)	.940 (23.9)	.491 (12.5)
14	15	.838 (21.3)	.940 (23.9)	.565 (14.4)
16	17	.963 (24.5)	.940 (23.9)	.690 (17.5)
18	19	1.042 (26.5)	.940 (23.9)	.769 (19.5)
20	21	1.217 (30.9)	.940 (23.9)	.894 (22.7)
22	23	1.355 (34.4)	.940 (23.9)	1.019 (25.9)
24	25	1.443 (36.7)	.940 (23.9)	1.134 (28.8)

**TABLE III: FINISH**

Symbol	Finish Description
<b>XB</b>	No Plating - Black Color (Non-Conductive Finish)
<b>XM</b>	2000 Hour Corrosion Resistant Electroless Nickel
<b>XMT</b>	2000 Hour Corrosion Resistant Ni-PTFE, Nickel-Fluorocarbon Polymer. <i>1000 Hour Grey™</i>
<b>XW</b>	2000 Hour Corrosion Resistant Cadmium/Olive Drab over Electroless Nickel
<b>XD</b>	No Plating, Desert Tan

**NOTES**

1. See Table I in Intro for front-end dimensional details.
2. **(Straight)** 770-001S\*\*-0 shrink boot supplied with "T" option.  
For angled boot, contact Glenair engineering.  
See shrink boot product page for more details.
3. O-ring supplied with H and F codes only.
4. Coupling nut supplied unplated.

# 310-017 Composite Shrink Boot Adapter with Direct Coupling Nut

A

CONNECTOR DESIGNATOR:	
<b>A</b>	MIL-DTL-5015, -26482, Series II and -83723 Series I and III
<b>F</b>	MIL-DTL-38999 Series I, II
<b>H</b>	MIL-DTL-38999 Series III and IV
<b>DIRECT COUPLING</b>	

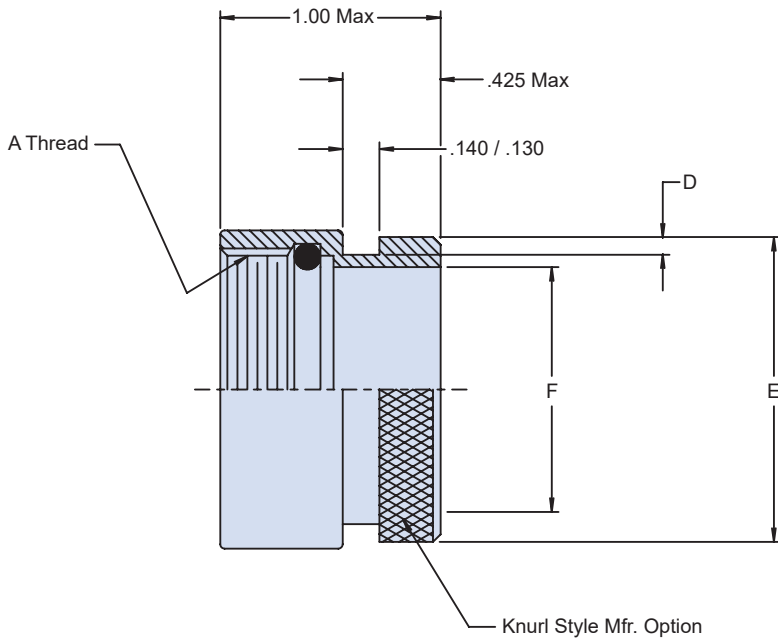
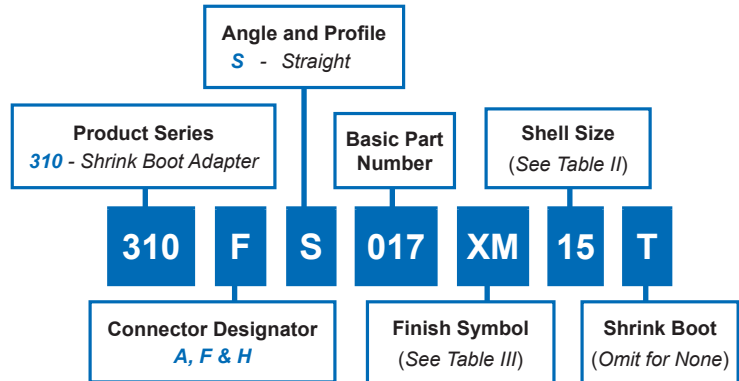


TABLE III: FINISH	
Symbol	Finish Description
XB	No Plating - Black Color (Non-Conductive Finish)
XO	Composite Material—No Plating, Color Black and Brown, Brass Interface Shroud and Adapter—Nickel Plated
XM	2000 Hour Corrosion Resistant Electroless Nickel
XMT	2000 Hour Corrosion Resistant Ni-PTFE, Nickel-Fluorocarbon Polymer. 1000 Hour Grey™
XW	2000 Hour Corrosion Resistant Cadmium/Olive Drab over Electroless Nickel

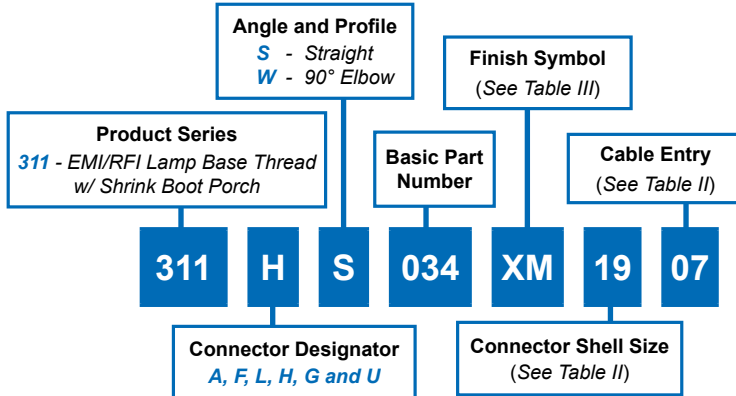
TABLE II: SHELL SIZE			
Shell Size	D	E	F
	+ .008 - .000	+ .000 - .045	
H			
09	.044 (1.1)	.612 (15.5)	.346 (8.8)
11	.044 (1.1)	.764 (19.4)	.475 (12.1)
13	.044 (1.1)	.857 (21.8)	.589 (15.0)
15	.044 (1.1)	.980 (24.9)	.714 (18.1)
17	.044 (1.1)	1.100 (27.9)	.839 (21.3)
19	.069 (1.8)	1.215 (30.9)	.945 (24.0)
21	.069 (1.8)	1.345 (34.2)	1.070 (27.2)
23	.069 (1.8)	1.465 (37.2)	1.195 (30.4)
25	.069 (1.8)	1.590 (40.4)	1.320 (33.5)

- | NOTES   |
|---|
| 1. See Table I in Intro for front-end dimensional details.  |
| 2. <b>(Straight)</b> 770-001S**-0 shrink boot supplied with "T" option. For angled shrink boot, contact Glenair engineering. See shrink boot product page for more details. |
| 3. O-Ring will not be supplied with Connector Designator A.   |

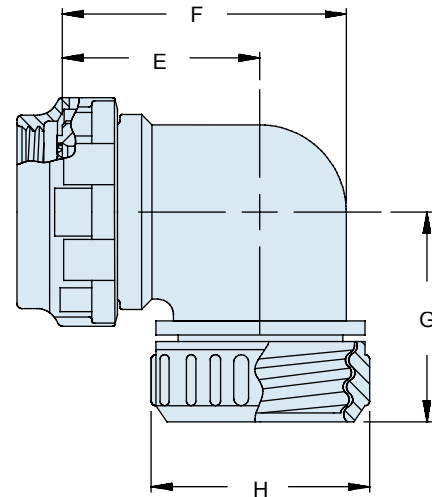
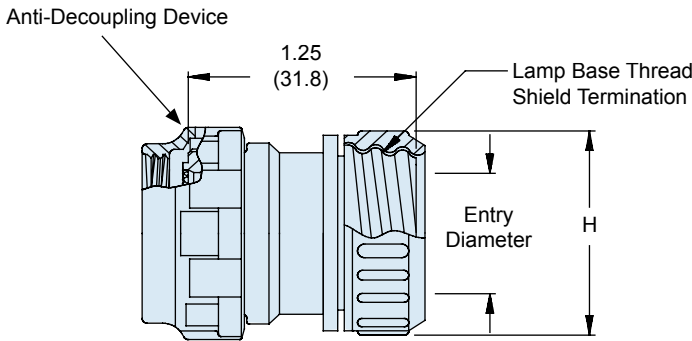
# 311-034 Composite Lamp Base Thread EMI/RFI Shield Termination Backshell with Self-Locking Rotatable Coupling Nut



A



Dash No.	±.06	H (1.5)	±.03	Entry Dia. (0.8)
01	.45	(11.4)	.13	(3.3)
02	.52	(13.2)	.25	(6.4)
03	.64	(16.3)	.38	(9.7)
04	.77	(19.6)	.50	(12.7)
05	.92	(23.4)	.63	(16.0)
06	1.02	(25.9)	.75	(19.1)
07	1.14	(29.0)	.81	(20.6)
08	1.27	(32.3)	.94	(23.9)
09	1.43	(36.3)	1.06	(26.9)
10	1.52	(38.6)	1.19	(30.2)
11	1.64	(41.7)	1.38	(35.1)



- NOTES
- See Table I in Intro for front-end dimensional details.
  - Coupling nut supplied unplated.
  - Metric dimensions (mm) are for reference only.

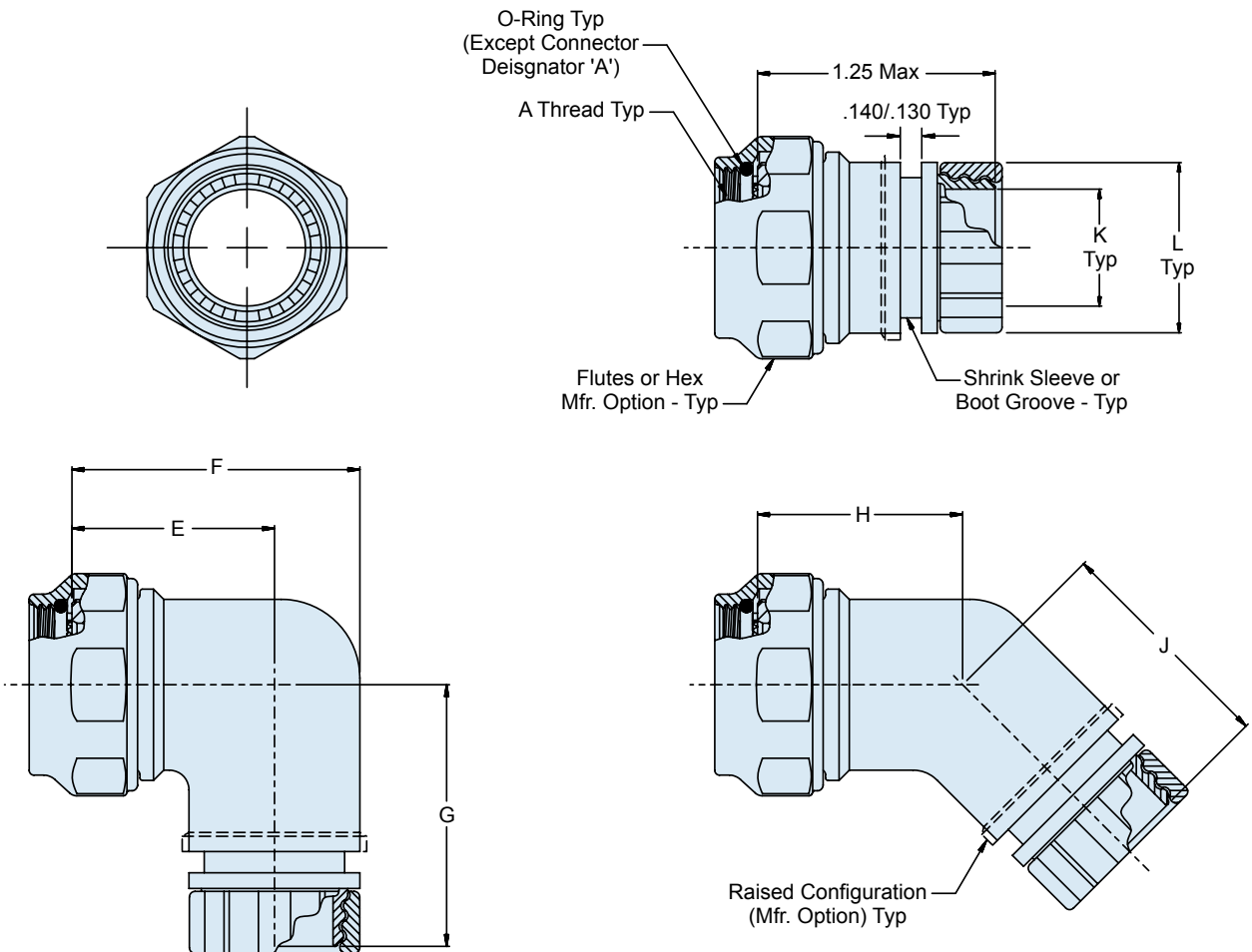
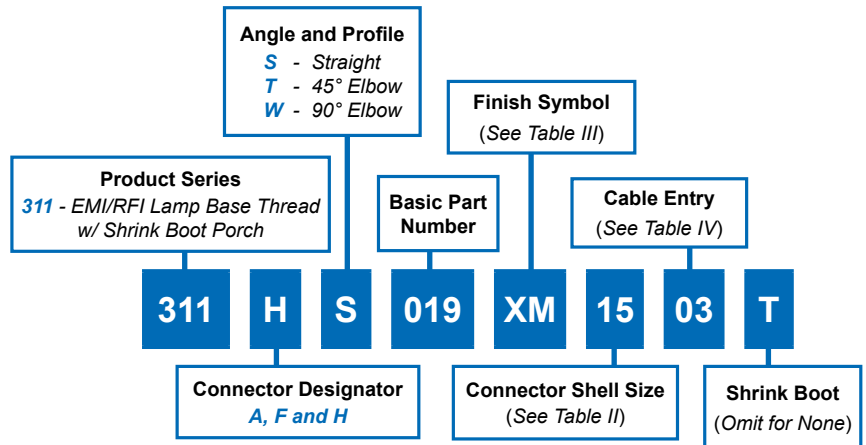
Shell Size For Connector Designator*					E	F	G	Max Entry Dash No.**
A	F/L	H	G	U	±.06 (1.5)	±.09 (2.3)	±.09 (2.3)	
08	08	09	-	-	.69 (17.5)	.88 (22.4)	1.19 (30.2)	02
10	10	11	-	08	.75 (19.1)	1.00 (25.4)	1.25 (31.8)	03
12	12	13	11	10	.81 (20.6)	1.13 (28.7)	1.31 (33.3)	04
14	14	15	13	12	.88 (22.4)	1.31 (33.3)	1.38 (35.1)	05
16	16	17	15	14	.94 (23.9)	1.38 (35.1)	1.44 (36.6)	06
18	18	19	17	16	.97 (24.6)	1.44 (36.6)	1.47 (37.3)	07
20	20	21	19	18	1.06 (26.9)	1.63 (41.4)	1.56 (39.6)	08
22	22	23	-	20	1.13 (28.7)	1.75 (44.5)	1.63 (41.4)	09
24	24	25	23	22	1.19 (30.2)	1.88 (47.8)	1.69 (42.9)	10
28	-	-	25	24	1.34 (34.0)	2.13 (54.1)	1.78 (45.2)	11

\*\*Consult factory for additional entry sizes available.  
See introduction for additional connector front-end details.

Symbol	Finish Description
XM	2000 Hour Corrosion Resistant Electroless Nickel
XMT	2000 Hour Corrosion Resistant Ni-PTFE, Nickel-Fluorocarbon Polymer. 1000 Hour Grey™
XW	2000 Hour Corrosion Resistant Cadmium/Olive Drab over Electroless Nickel

**A**

CONNECTOR DESIGNATOR:	
<b>A</b>	MIL-DTL-5015, -26482 Series II, and -83723 Series I and III
<b>F</b>	MIL-DTL-38999 Series I, II
<b>H</b>	MIL-DTL-38999 Series III and IV
<b>SELF-LOCKING</b>	
<b>ROTATABLE COUPLING</b>	
<b>STANDARD PROFILE</b>	



**311-019**  
**Composite Lamp Base Thread**  
**EMI/RFI Shield Termination Backshell**  
**with Shrink Boot Porch and Self-Locking Rotatable Coupling**



**TABLE II: SHELL SIZE**

Shell Size		E ± .06	F ± .09	G ± .09	H ± .06	J ± .09	Max Dash Number (Table II)
A, F	H						
08	09	0.69 (17.5)	0.88 (22.4)	1.19 (30.2)	0.72 (18.3)	1.00 (25.4)	02
10	11	0.75 (19.1)	1.00 (25.4)	1.25 (31.8)	0.75 (19.1)	1.06 (26.9)	03
12	13	0.81 (20.6)	1.13 (28.7)	1.31 (33.3)	0.75 (19.1)	1.13 (28.7)	04
14	15	0.88 (22.4)	1.31 (33.3)	1.38 (35.1)	0.76 (19.3)	1.16 (29.5)	05
16	17	0.94 (23.9)	1.38 (35.1)	1.44 (36.6)	0.78 (19.8)	1.18 (30.0)	06
18	19	0.97 (24.6)	1.44 (36.6)	1.47 (37.3)	0.79 (20.1)	1.19 (30.2)	07
20	21	1.06 (26.9)	1.63 (41.4)	1.56 (39.6)	0.82 (20.8)	1.22 (31.0)	08
22	23	1.13 (28.7)	1.75 (44.5)	1.63 (41.4)	0.86 (21.8)	1.26 (32.0)	09
24	25	1.19 (30.2)	1.88 (47.8)	1.69 (42.9)	0.89 (22.6)	1.29 (32.8)	10

**TABLE IV: ENTRY DIAMETER**

Dash Number	K Entry ± .03	L ± .06
01	.13 (3.3)	.45 (11.4)
02	.25 (6.4)	.52 (13.2)
03	.38 (9.7)	.64 (16.3)
04	.50 (12.7)	.77 (19.6)
05	.63 (16.0)	.92 (23.4)
06	.75 (19.1)	1.02 (25.9)
07	.81 (20.6)	1.14 (29.0)
08	.94 (23.9)	1.27 (32.3)
09	1.06 (26.9)	1.43 (36.3)
10	1.19 (30.2)	1.52 (38.6)
11	1.38 (35.1)	1.64 (41.7)

**TABLE III: FINISH**

Symbol	Finish Description
XM	2000 Hour Corrosion Resistant Electroless Nickel
XMT	2000 Hour Corrosion Resistant Ni-PTFE, Nickel-Fluorocarbon Polymer. <i>1000 Hour Grey™</i>
XW	2000 Hour Corrosion Resistant Cadmium/Olive Drab over Electroless Nickel

**NOTES**

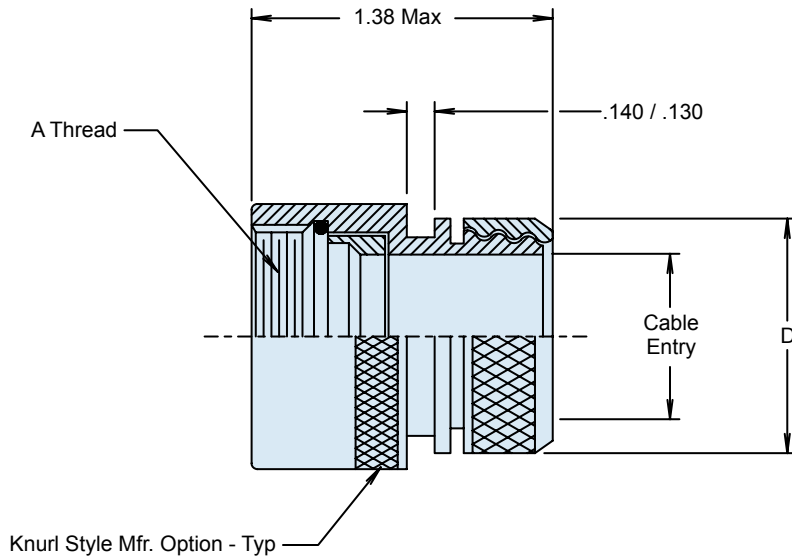
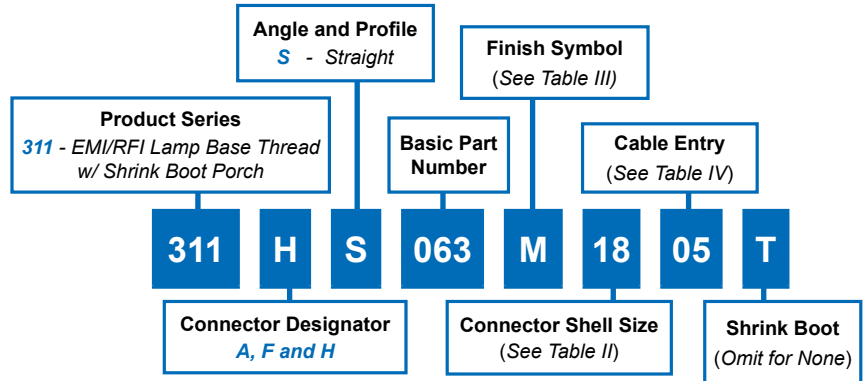
1. See Table I in Intro for front-end dimensional details.
2. 770-001S\*\*-0 shrink boot supplied with T option. See shrink boot product page for more details.
3. O-Ring will not be supplied with Connector Designator A.
4. Coupling nut supplied unplated.



# 311-063 Composite Lamp Base Thread EMI/RFI Environmental Shield Termination Backshell with Shrink Boot Porch and Direct Coupling Nut

**A**

CONNECTOR DESIGNATOR:	
<b>A</b>	MIL-DTL-5015, -26482 Series II, and -83723 Series I and III
<b>F</b>	MIL-DTL-38999 Series I, II
<b>H</b>	MIL-DTL-38999 Series III and IV
<b>DIRECT COUPLING</b>	



Shell Size		Max Dash Number
A, F	H	
08	09	02
10	11	03
12	13	04
14	15	05
16	17	06
18	19	07
20	21	08
22	23	09
24	25	10

**311-063**  
**Composite Lamp Base Thread**  
**EMI/RFI Environmental Shield Termination Backshell**  
**with Shrink Boot Porch and Direct Coupling Nut**



TABLE III: FINISH	
Symbol	Finish Description
XM	2000 Hour Corrosion Resistant Electroless Nickel
XMT	2000 Hour Corrosion Resistant Ni-PTFE, Nickel-Fluorocarbon Polymer. <i>1000 Hour Grey™</i>
XW	2000 Hour Corrosion Resistant Cadmium/Olive Drab over Electroless Nickel

TABLE IV: CABLE ENTRY		
Dash Number	D Max	Entry Max
01	.448 (11.4)	.13 (3.3)
02	.515 (13.1)	.25 (6.4)
03	.640 (16.3)	.38 (9.7)
04	.765 (19.4)	.50 (12.7)
05	.930 (23.6)	.63 (16.0)
06	1.015 (25.8)	.75 (19.1)
07	1.140 (29.0)	.81 (20.6)
08	1.265 (32.1)	1.06 (26.9)
09	1.432 (36.4)	1.19 (30.2)
10	1.515 (38.5)	1.38 (35.1)

NOTES
1. See Table I in Intro for front-end dimensional details.
2. For angled shrink boots, contact Glenair engineering.
3. 770-001S**-0 shrink boot supplied with T option. See shrink boot product page for more details.
4. O-Ring will not be supplied with Connector Designator A.

A

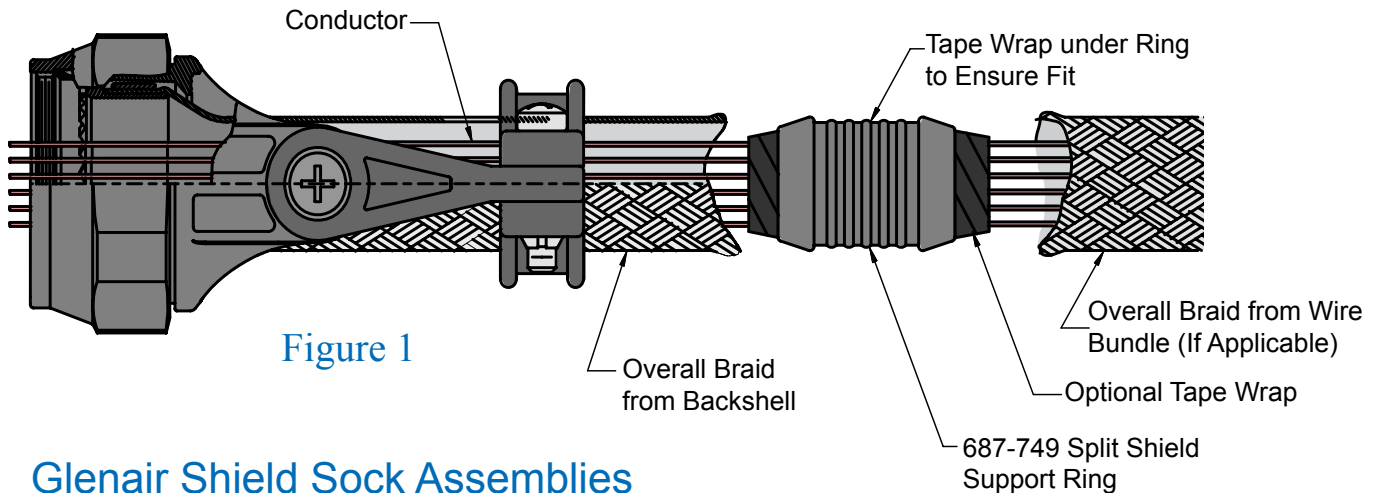


Figure 1

## Glenair Shield Sock Assemblies Offer Fast and Trouble-Free Termination of EMI Shielding:

For Swing-Arm type shield sock backshells, choose Straight, 45° or 90° angle, and tighten screws to lock arms in place. For standard shield socks, ignore this step. For styles equipped with strain relief clamps, leave the saddle clamp hardware loose.

Next, insert the wire bundle into the backshell to determine if the braid transition angle from the backshell to wire bundle is less than 45°. If it is less than 45°, build up the wire bundle with tape and re-insert wire bundle into backshell to support the transition of overall braid from the backshell to the wire bundle.

Loosely assembly the adapter to the connector and push back the backshell braid. Insert the wire bundle into the adapter and bottom it against the connector. Holding the cable, mark or tag the location where the shield support ring (Glenair Part Number 687-749) will be located. This distance may vary depending on your technique and the flexibility of the wire bundle immediately to the rear of the saddles (Figure 1).

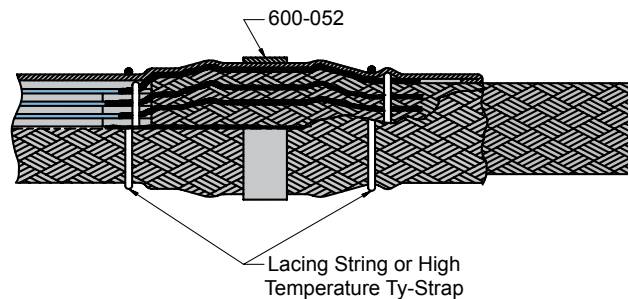


Figure 2

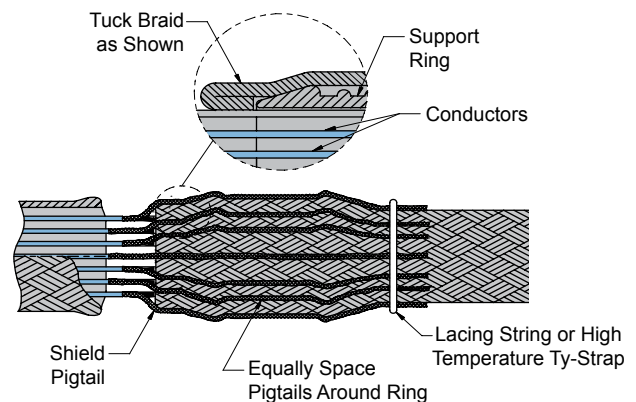


Figure 3



# Composite Thermoplastic Shield Sock Assembly Procedure

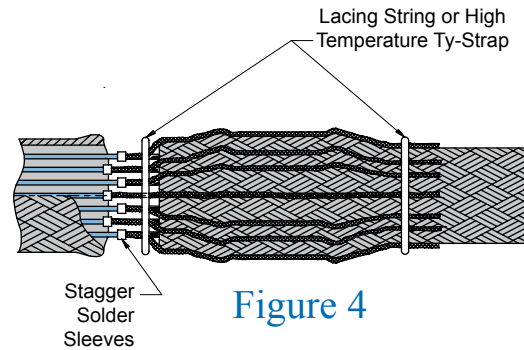


At the marked location, near the shield support ring, wrap tape around wire bundle for snug fit of shield support ring (Figure 1). Tape wrap is optional.

You can then slide the overall braid from the wire bundle side over the shield support ring, trimming braid ends and tucking extra braid underneath itself for a clean appearance.

For pin connectors, slide the backshell forward, and hand tighten backshell to connector. Then, evenly space shield pigtails (Figure 3) or solder sleeve pigtails (Figure 4) around the shield support ring. Cut the pigtails so that they extend slightly beyond end of shield support ring.

Bring the shield sock from backshell and completely cover the pigtails and support ring. Trim and fold the braid as shown in Figure 2. Lace tie the shield adjacent to support ring ends.

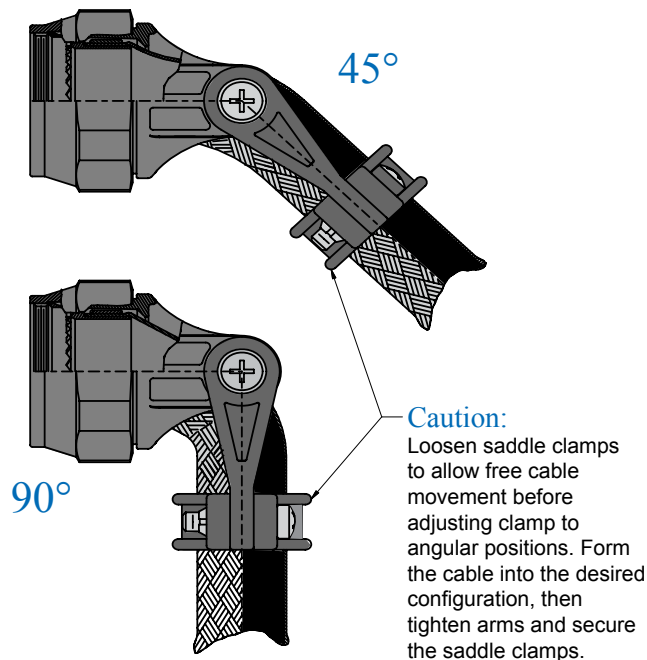


Install Glenair's *Band-it*<sup>®</sup> band (600-052) between the lace ties onto the center of the support ring as shown in Figure 2. The hand banding tool (600-058) or pneumatic banding tool (600-067) is used for this banding process.

Next, wrap the shield support ring assembly with high temperature tape. Place lacing cord, high temperature tape, or high temperature plastic Ty-Straps on the braid transition to the rear of the backshell to secure the overbraid on wire bundle. If you wish, you can cover the overbraid with 102-080 braid sock.

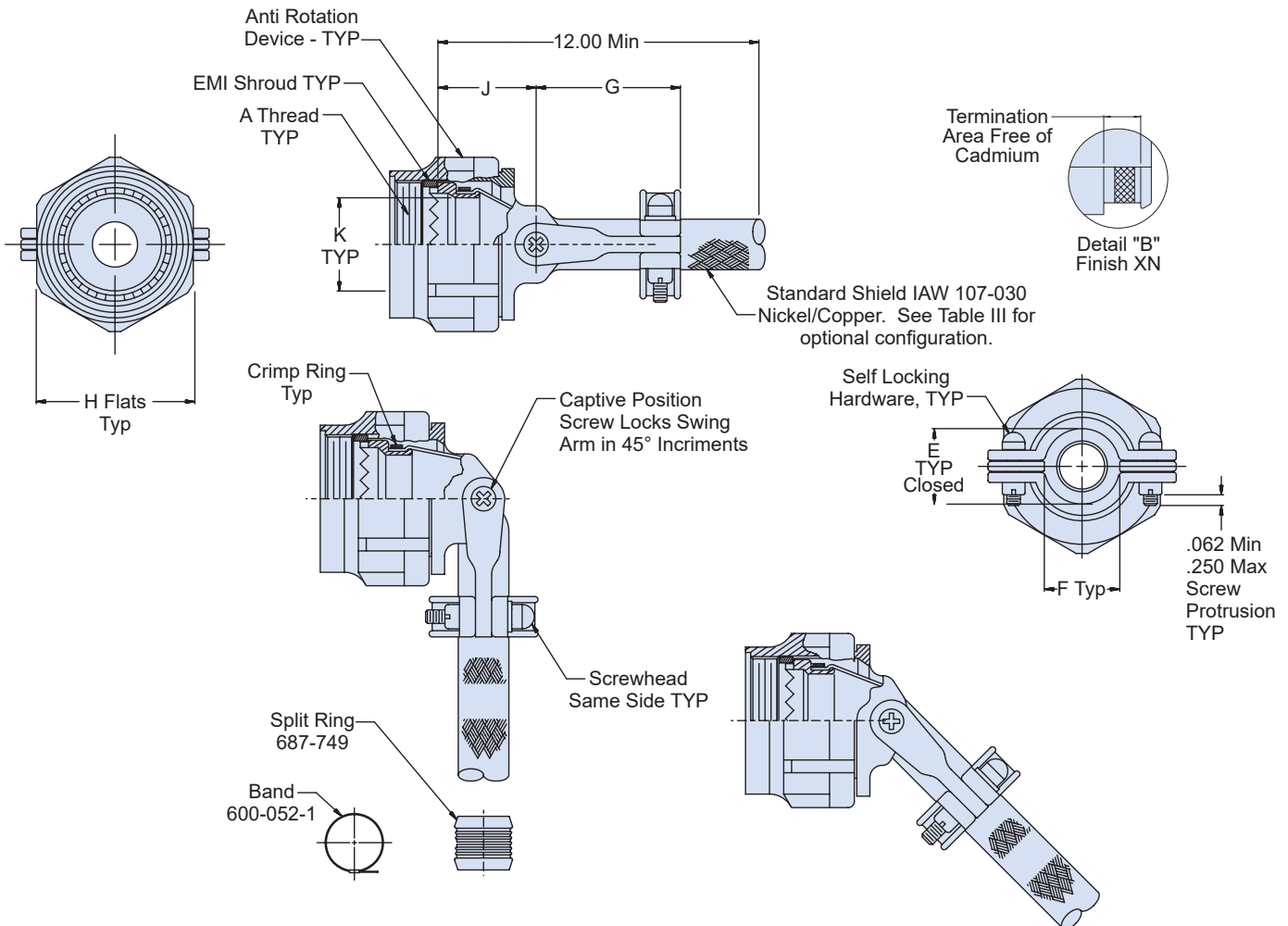
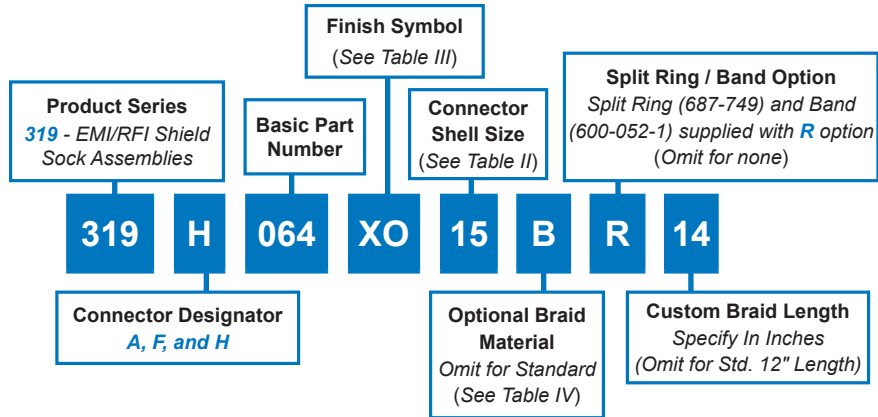
Tighten the adapter to the connector using established torque values with Glenair 600-091 or 600-157 composite hex coupling wrench and related tooling accessories. Where applicable, secure strain relief saddles onto the wire bundle using TG69 soft jaw pliers. Torque saddle screws to established values. Teflon tape wrap or AS85049/127 bushing strips may be used as needed to cushion the braid sock under the saddle clamps.

With these few steps, your Shield Sock installation is complete!



A

CONNECTOR DESIGNATOR:	
<b>A</b>	MIL-DTL-5015, -26482 Series II, and -83723 Series I and III
<b>F</b>	MIL-DTL-38999 Series I, for Series II See Note 3
<b>H</b>	MIL-DTL-38999 Series III and IV
<b>SELF-LOCKING</b>	
<b>ROTATABLE COUPLING</b>	



U.S. PATENT NO. 6419519

**319-064**  
**Composite Swing-Arm Backshell**  
 with Shield Sock and  
 Self-Locking Rotatable Coupling



**TABLE II: SHELL SIZE**

Shell Size		E	F Min.	G Max.	H		J ± .06	K Min. (H Code)	K Min. (A Code)	K Min. (F Code)
A, F	H				Max.	Min.				
08	09	.265 (6.7)	.22 (5.6)	1.06 (26.9)	.750 (19.05)	.736 (18.69)	.94 (23.9)	.264 (6.7)	.265 (6.7)	.269 ±.005 (6.8 ±.02)
10	11	.310 (7.9)	.27 (6.9)	1.09 (27.7)	.875 (22.2)	.860 (21.84)	.97 (24.6)	.390 (9.9)	.370 (9.4)	.402 ±.010 (10.2 ±.25)
12	13	.422 (10.7)	.35 (8.9)	1.18 (30.0)	1.000 (25.4)	.980 (24.89)	1.03 (26.2)	.504 (12.8)	.506 (12.9)	.516 ±.010 (13.1 ±.25)
14	15	.538 (12.9)	.47 (11.9)	1.24 (31.5)	1.125 (28.6)	1.100 (27.94)	1.09 (27.7)	.630 (16.0)	.580 (14.7)	.641 ±.010 (16.3 ±.25)
16	17	.591 (15.0)	.55 (14.0)	1.32 (33.5)	1.250 (31.8)	1.224 (31.09)	1.12 (28.4)	.756 (19.2)	.705 (17.9)	.766 ±.010 (19.5 ±.25)
18	19	.661 (16.8)	.62 (15.7)	1.39 (35.3)	1.375 (34.9)	1.348 (34.24)	1.15 (29.2)	.843 (21.4)	.784 (19.9)	.853 ±.019 (19.5 ±.48)
20	21	.744 (18.9)	.70 (17.8)	1.49 (37.8)	1.500 (38.1)	1.469 (37.31)	1.18 (30.0)	.969 (24.6)	.909 (23.1)	.988 ±.019 (25.1 ±.48)
22	23	.826 (21.0)	.78 (19.8)	1.55 (39.4)	1.625 (41.3)	1.581 (40.16)	1.25 (31.8)	1.091 (27.7)	1.034 (26.3)	1.113 ±.019 (28.3 ±.48)
24	25	.896 (22.8)	.85 (21.6)	1.61 (40.9)	1.725 (43.8)	1.690 (42.93)	1.28 (32.5)	1.217 (30.9)	1.149 (29.2)	1.238 ±.019 (31.5 ±.25)

**TABLE III: FINISH**

Symbol	Finish
<b>XB</b>	Composite Material—No Plating, Color Black, Brass Interface Shroud and Adapter—Nickel Plated
<b>XMT</b>	2000 Hour Corrosion Resistant Ni-PTFE, Nickel-Fluorocarbon Polymer. <i>1000 Hour Grey™</i>
<b>XN</b>	Composite Material—No Plating, Color Black and Brown, Brass Interface Shroud and Adapter—Selectively Cadmium Plated (See Detail B)
<b>XO</b>	Composite Material—No Plating, Color Black and Brown, Brass Interface Shroud and Adapter—Nickel Plated

**TABLE IV: BRAID TYPE**

Symbol	Braid Type
A	100% AmberStrand®
B	75%/25% AmberStrand® Blend
L	100% ArmorLite™
<i>Standard</i>	Nickel/Copper 34awg
T	Tin/Copper 34awg

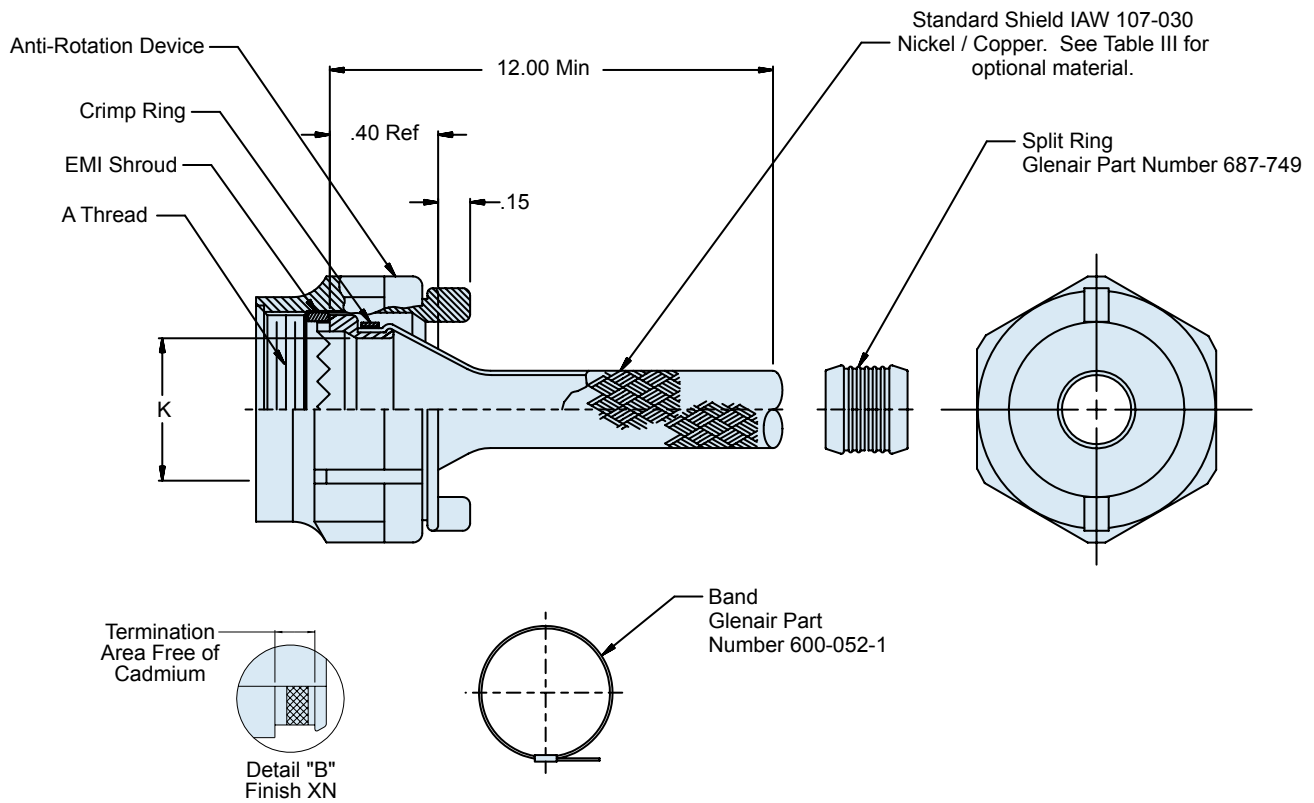
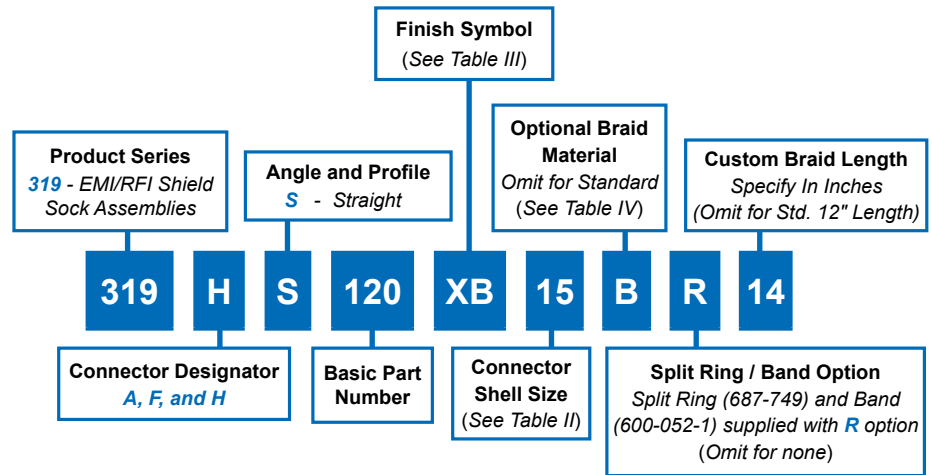
**NOTES**

1. See Table I in Intro for front-end dimensional details.
2. See composite thermoplastic shield sock assembly procedure for detailed installation instructions.
3. Add mod code -475 to end of part number for use with Series II connectors. Backshell to be supplied less shroud.
4. Coupling nut supplied unplated.

# 319-120 Composite EMI/RFI Backshell with Shield Sock and Self-Locking Rotatable Coupling

A

CONNECTOR DESIGNATOR:	
<b>A</b>	MIL-DTL-5015, -26482 Series II, and -83723 Series I and III
<b>F</b>	MIL-DTL-38999 Series I, for Series II see note 3
<b>H</b>	MIL-DTL-38999 Series III and IV
<b>SELF-LOCKING</b>	
<b>ROTATABLE COUPLING</b>	
<b>LOW PROFILE</b>	



**319-120**  
**Composite EMI/RFI Backshell**  
 with Shield Sock and  
 Self-Locking Rotatable Coupling



TABLE II: SHELL SIZE				
Shell Size		K Diameter		
A, F	H	A Code	F Code	H Code
08	09	.265 (6.7)	.275 (7.0)	.264 (6.7)
10	11	.370 (9.4)	.412 (10.5)	.390 (9.9)
12	13	.506 (12.9)	.526 (13.4)	.504 (12.8)
14	15	.580 (14.7)	.651 (16.5)	.630 (16.0)
16	17	.705 (17.9)	.776 (19.7)	.756 (19.2)
18	19	.784 (19.9)	.872 (22.1)	.843 (21.4)
20	21	.909 (23.1)	1.007 (25.6)	.969 (24.6)
22	23	1.034 (26.3)	1.132 (28.8)	1.091 (27.7)
24	25	1.149 (29.2)	1.257 (31.9)	1.217 (30.9)

TABLE III: FINISH	
Symbol	Finish
<b>XB</b>	Composite Material—No Plating, Color Black, Brass Interface Shroud and Adapter—Nickel Plated
<b>XMT</b>	2000 Hour Corrosion Resistant Ni-PTFE, Nickel-Fluorocarbon Polymer. <i>1000 Hour Grey™</i>
<b>XN</b>	Composite Material—No Plating, Color Black and Brown, Brass Interface Shroud and Adapter—Selectively Cadmium Plated (See Detail B)

TABLE IV: BRAID TYPE	
Symbol	Braid Type
A	100% AmberStrand®
B	75%/25% AmberStrand® Blend
L	100% ArmorLite™
<i>Standard</i>	Nickel/Copper 34awg
T	Tin/Copper 34awg

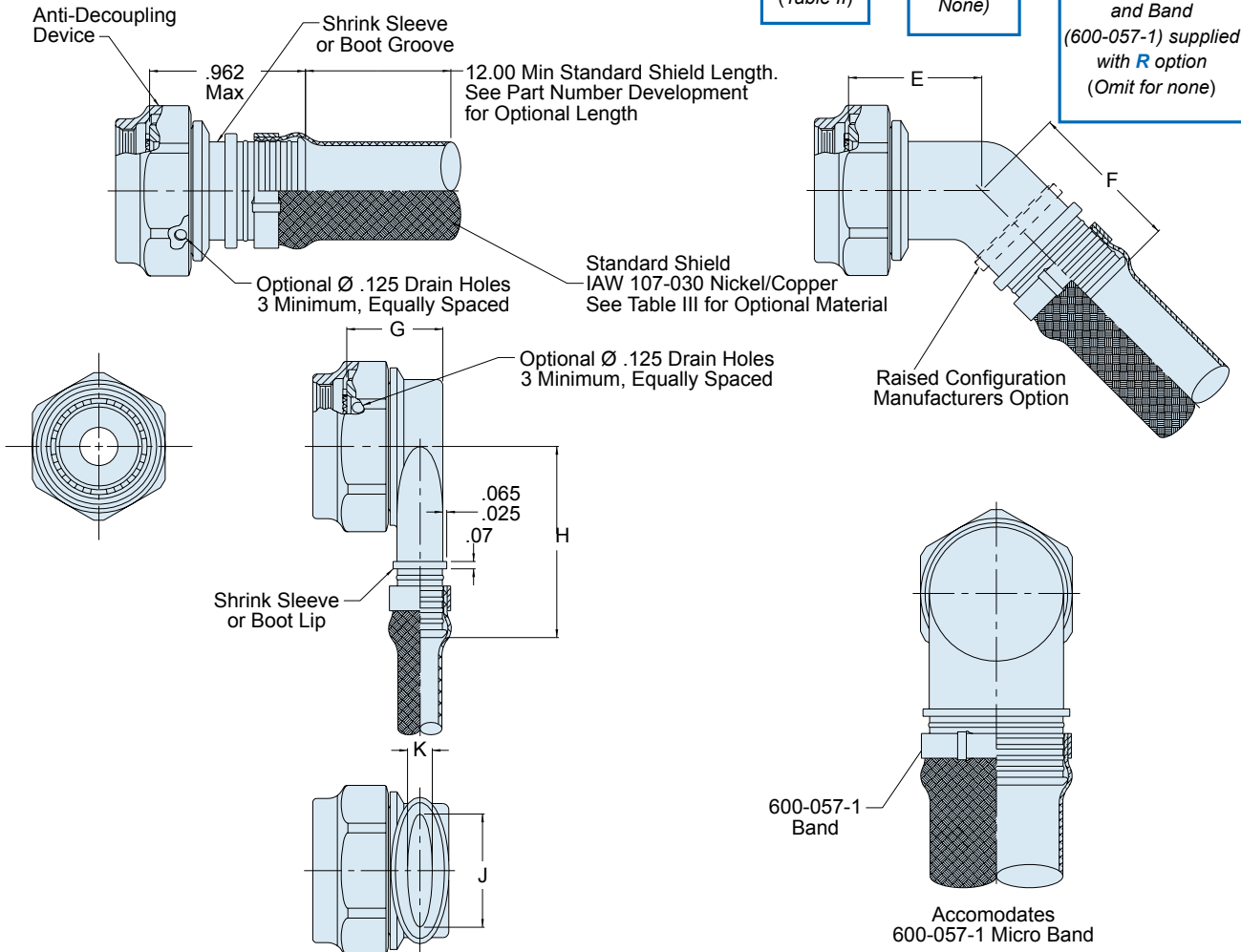
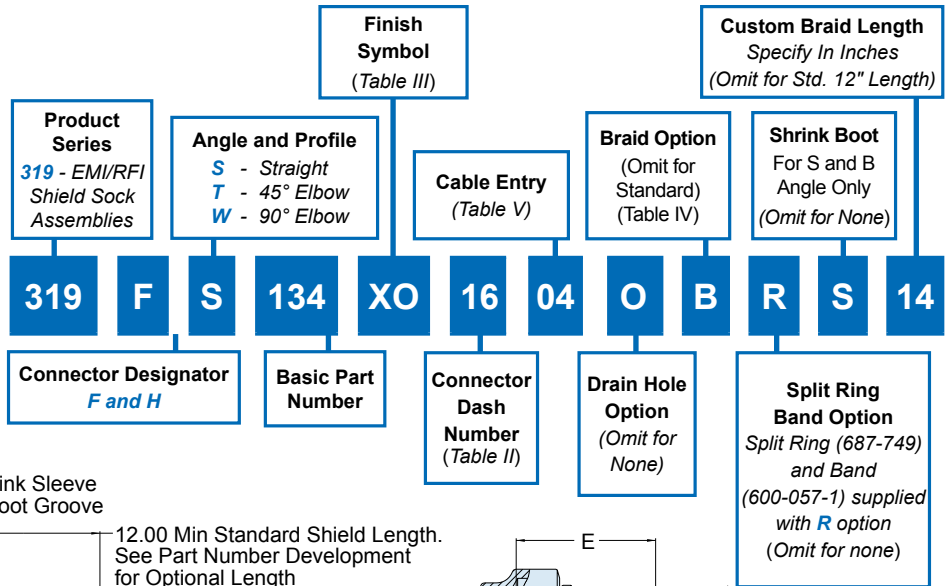
**NOTES**

1. See Table I in Intro for front-end dimensional details.
2. See composite thermoplastic shield sock assembly procedure for detailed installation instructions.
3. Add mod code -475 to end of part number for use with Series II connectors. Backshell to be supplied less shroud.
4. Coupling nuts supplied unplated.

# 319-134 Composite EMI/RFI Ultra Low-Profile Shield Sock with Shrink Boot Porch and Self Locking Rotatable Coupling

A

CONNECTOR DESIGNATOR:	
<b>F</b>	MIL-DTL-38999 Series I, II
<b>H</b>	MIL-DTL-38999 Series III and IV
<b>SELF-LOCKING</b>	
<b>ROTATABLE COUPLING</b>	
<b>STANDARD PROFILE</b>	





**TABLE II: SHELL SIZE (Continued Below)**

Connector Designator F					Connector Designator H				
Dash No.	Shell Size	A Thread Class 2A	B Dia Max	L Max	Dash No.	Shell Size	A Thread ISO metric	B Dia Max	L Max
08	08	7/15-28 UNEF	.59 (15.0)	.274 (7.0)	09	09 (A)	M12 x 1.0 - 6H	.65 (16.5)	.264 (6.7)
10	10	9/16-24 UNEF	.72 (18.3)	.412 (10.5)	11	11 (B)	M15 x 1.0 - 6H	.77 (19.6)	.390 (9.9)
12	12	11/16-24 UNEF	.84 (21.3)	.526 (13.4)	13	13 (C)	M18 x 1.0 - 6H	.89 (22.6)	.504 (12.8)
15	15	13/16-20 UNEF	.97 (24.6)	.651 (16.5)	15	15 (D)	M22 x 1.0 - 6H	1.03 (26.2)	.630 (16.0)
16	16	15/16-20 UNEF	1.09 (27.7)	.776 (19.7)	17	17 (E)	M25 x 1.0 - 6H	1.15 (29.2)	.756 (19.2)
18	18	1 1/16-18 UNEF	1.22 (31.0)	.872 (22.1)	19	19 (F)	M28 x 1.0 - 6H	1.28 (32.5)	.843 (21.4)
20	20	1 3/16-18 UNEF	1.34 (34.0)	1.007 (25.6)	21	21 (G)	M31 x 1.0 - 6H	1.41 (35.8)	.969 (24.6)
22	22	1 5/16-18 UNEF	.47 (37.3)	1.132 (28.8)	23	23 (H)	M34 x 1.0 - 6H	1.53 (38.9)	1.091 (27.7)
24	24	1 7/16-18 UNEF	1.59 (40.4)	1.257 (31.9)	25	25 (J)	M37 x 1.0 - 6H	1.66 (42.2)	1.217 (30.9)

**TABLE II: SHELL SIZE (Continued From Above)**

Connector Designator F		Connector Designator H		C Max	D Flats Max	E ± .06 (1.5)	F ± .09 (2.3)	G Max	H ± .03 (0.8)	J	K	Available Entry Code See Table V and Note 4
Dash No.	Shell Size	Dash No.	Shell Size									
08	08	09	09 (A)	.86 (21.8)	.75 (19.1)	.72 (18.3)	.87 (22.1)	.63 (16.0)	1.042 (26.5)	.304 (7.7)	.160 (4.1)	04
10	10	11	11 (B)	.98 (24.9)	.88 (22.2)	.75 (19.1)	.93 (23.6)	.66 (16.8)	1.107 (28.1)	.432 (11.0)	.174 (4.4)	05
12	12	13	13 (C)	1.16 (29.4)	1.00 (25.4)	.75 (19.1)	1.00 (25.4)	.72 (18.3)	1.174 (29.8)	.546 (13.9)	.195 (5.0)	07
15	15	15	15 (D)	1.28 (32.5)	1.13 (28.6)	.76 (19.3)	1.03 (26.2)	.83 (21.1)	1.241 (31.5)	.670 (17.0)	.315 (8.0)	09
16	16	17	17 (E)	1.41 (35.7)	1.25 (31.8)	.78 (19.8)	1.05 (26.7)	.91 (23.1)	1.305 (33.1)	.796 (20.2)	.385 (9.8)	05, 11
18	18	19	19 (F)	1.52 (38.5)	1.38 (39.9)	.79 (20.1)	1.06 (26.9)	.93 (23.6)	1.371 (34.8)	.902 (22.9)	.445 (11.3)	07, 13
20	20	21	21 (G)	1.64 (41.7)	1.50 (38.1)	.82 (20.8)	1.09 (27.7)	1.04 (26.4)	1.438 (36.5)	1.027 (26.1)	.525 (13.3)	09, 15
22	22	23	23 (H)	1.77 (44.9)	1.63 (41.3)	.86 (21.8)	1.13 (28.7)	1.12 (28.4)	1.505 (38.2)	1.152 (29.3)	.595 (15.1)	11, 16
24	24	25	25 (J)	1.89 (48.0)	1.75 (44.5)	.89 (22.6)	1.16 (29.5)	1.18 (30.0)	1.572 (39.9)	1.276 (32.4)	.655 (16.6)	07, 13, 17

**TABLE III: FINISH**

Symbol	Finish Description
XM	2000 Hour Corrosion Resistant Electroless Nickel
XMT	2000 Hour Corrosion Resistant Ni-PTFE, Nickel-Fluorocarbon Polymer. <i>1000 Hour Grey™</i>
XW	2000 Hour Corrosion Resistant Cadmium Olive Drab Over Electroless Nickel

**TABLE IV: BRAID TYPE**

Symbol	Braid Type
A	100% AmberStrand®
B	75%/25% AmberStrand® Blend
L	100% ArmorLite™
Standard	Nickel/Copper 34awg
T	Tin/Copper 34awg

**TABLE V: CABLE ENTRY**

Dash Number	D ± .03
04	.25 (6.4)
05	.31 (7.9)
07	.44 (11.2)
09	.56 (14.2)
11	.68 (17.3)
13	.81 (20.6)
15	.94 (23.9)
16	1.00 (25.4)
17	1.16 (29.5)

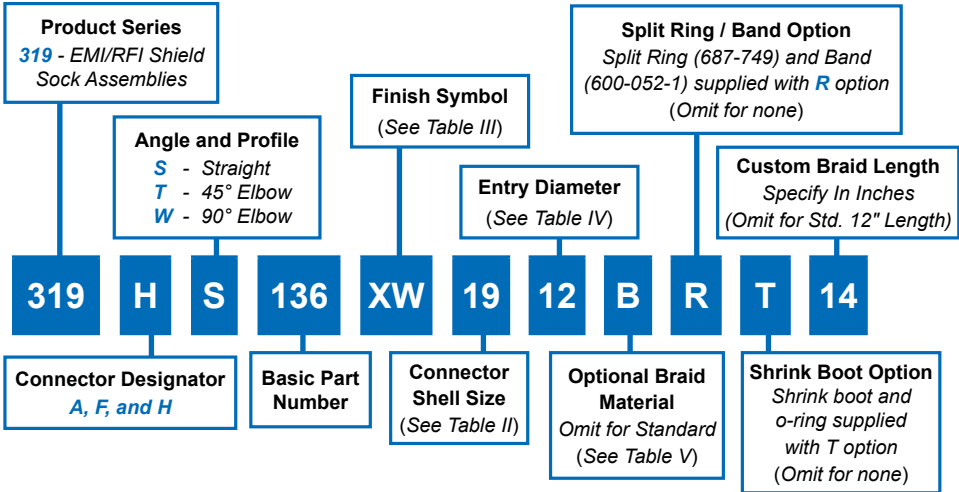
**NOTES**

- Assembly identified with manufacturer's name and part number, space permitting.
- Glenair Series 600 Backshell Assembly Tools are recommended for assembly and installation.
- 700-001S\*\*-0 shrink boot supplied with S option. For S and T configurations only.
- Entry codes are applicable for S and T configurations only.
- Material/Finish:  
 Clamp Body - High grade engineering thermoplastic/Table III.  
 Coupling Nut - High grade engineering thermoplastic/Unplated.  
 Anti-Rotation De vice - Corrosion resistant material.  
 Shield - See part number development.

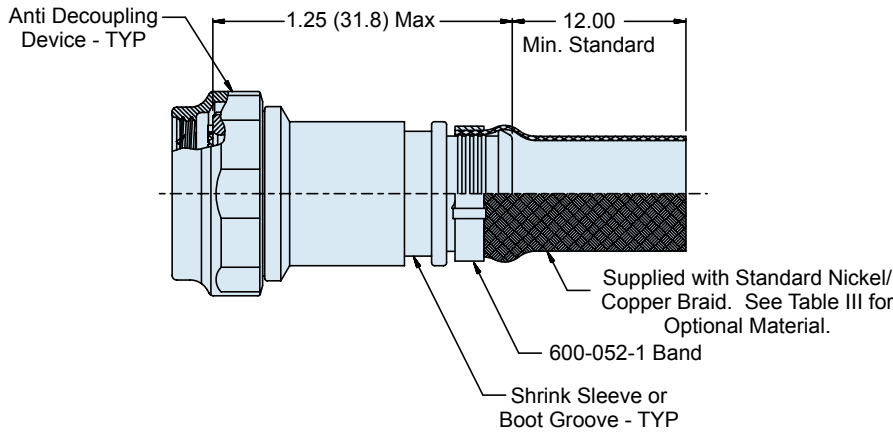
# 319-136 Composite EMI/RFI Shield Sock with Shrink Boot Porch and Self-Locking Rotatable Coupling

A

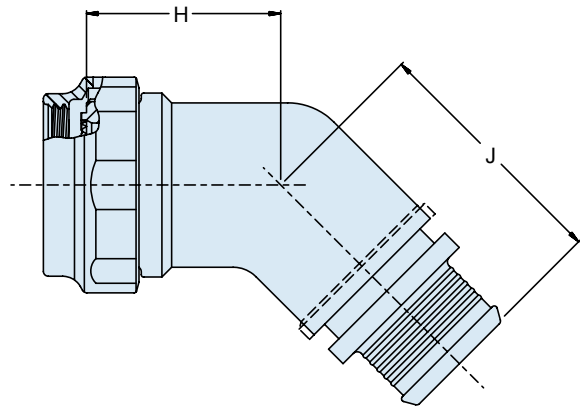
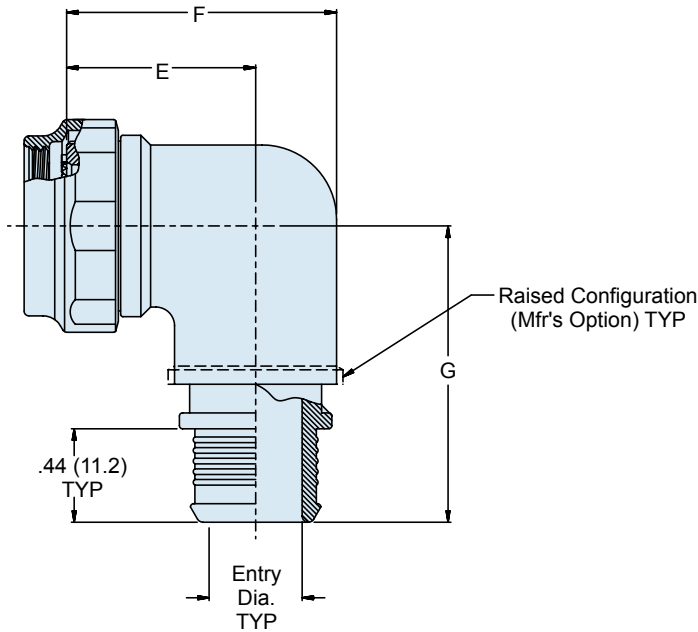
CONNECTOR DESIGNATOR:	
<b>A</b>	MIL-DTL-5015, -26482 Series II, and -83723 Series I and III
<b>F</b>	MIL-DTL-38999 Series I, II
<b>H</b>	MIL-DTL-38999 Series III and IV
<b>SELF-LOCKING</b>	
<b>ROTATABLE COUPLING</b>	
<b>STANDARD PROFILE</b>	



**319 H S 136 XW 19 12 B R T 14**



- ### NOTES
- 770-001S\*\*-0 shrink boot supplied with T option. See shrink boot product page for more details.
  - Coupling nut supplied unplated.
  - See Table I in Intro for front-end dimensional details.
  - O-Ring will not be supplied with Designator A.





**319-136**  
**Composite EMI/RFI Shield Sock**  
**with Shrink Boot Porch and Self-Locking Rotatable Coupling**



Composite Backshells

**A**

**TABLE II: SHELL SIZE**

Shell Size		E ± .06 (1.5)	F ± .09 (2.3)	G ± .09 (2.3)	H ± .06 (1.5)	J ± .09 (2.3)	Max. Entry Dash Number (Table III)
A, F	H						
08	09	.69 (17.5)	.88 (22.4)	1.19 (30.2)	.72 (18.3)	1.00 (25.4)	04
10	11	.75 (19.1)	1.00 (25.4)	1.25 (31.8)	.75 (19.1)	1.06 (26.9)	06
12	13	.81 (20.6)	1.13 (28.7)	1.31 (33.3)	.75 (19.1)	1.13 (28.7)	08
14	15	.88 (22.4)	1.31 (33.3)	1.38 (35.1)	.76 (19.3)	1.16 (29.5)	10
16	17	.94 (23.9)	1.38 (35.1)	1.44 (36.6)	.78 (19.8)	1.18 (30.0)	12
18	19	.97 (24.6)	1.44 (36.6)	1.47 (37.3)	.79 (20.1)	1.19 (30.2)	13
20	21	1.06 (26.9)	1.63 (41.4)	1.56 (39.6)	.82 (20.8)	1.22 (31.0)	15
22	23	1.13 (28.7)	1.75 (44.5)	1.63 (41.4)	.86 (21.8)	1.26 (32.0)	17
24	25	1.19 (30.2)	1.88 (47.8)	1.69 (42.9)	.89 (22.6)	1.29 (32.8)	19
28	-	1.34 (34.0)	2.13 (54.1)	1.78 (45.2)	.92 (23.4)	1.32 (33.5)	22

**TABLE III: FINISH**

Symbol	Finish Description
XM	2000 Hour Corrosion Resistant Electroless Nickel
XMT	2000 Hour Corrosion Resistant Ni-PTFE, Nickel-Fluorocarbon Polymer. <i>1000 Hour Grey™</i>
XW	2000 Hour Corrosion Resistant Cadmium Olive Drab Over Electroless Nickel

**TABLE IV: ENTRY**

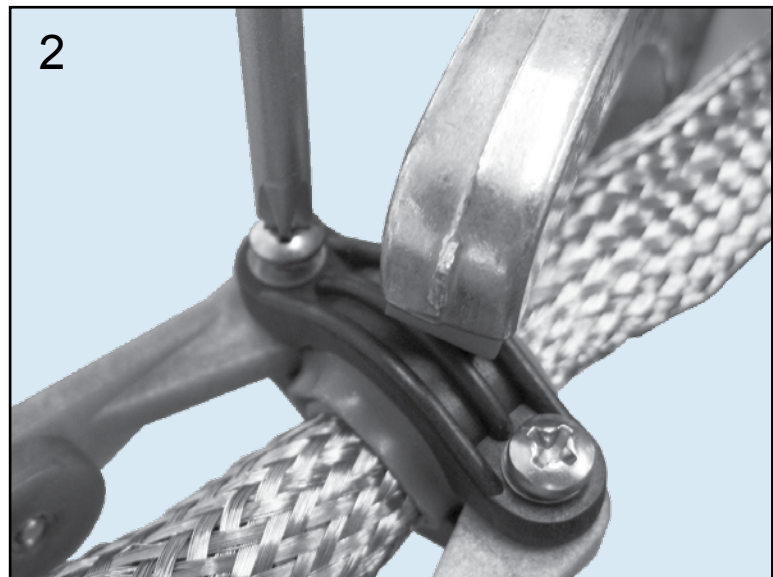
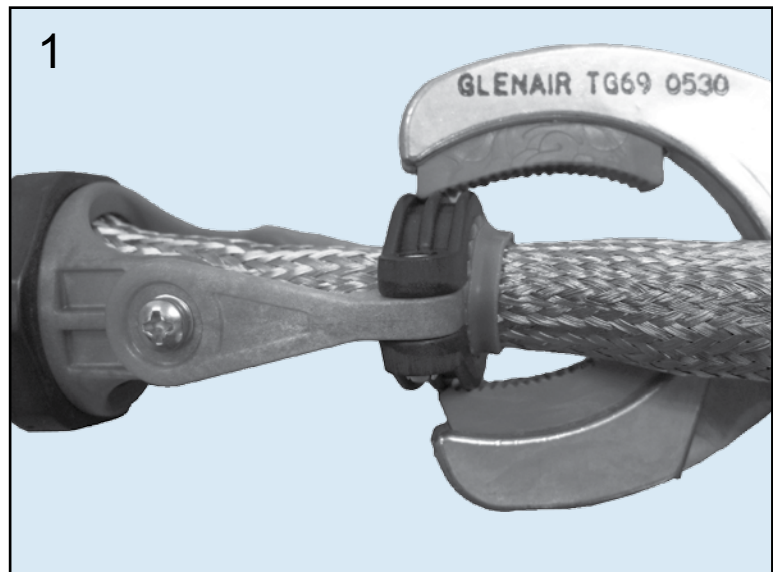
Dash Number	Entry Diameter ± .03 (0.8)
03	.19 (4.8)
04	.25 (6.4)
05	.31 (7.9)
06	.38 (9.7)
07	.44 (11.2)
08	.50 (12.7)
09	.56 (14.2)
10	.63 (16.0)
11	.69 (17.5)
12	.75 (19.1)
13	.81 (20.6)
14	.88 (22.4)
15	.94 (23.9)
16	1.00 (25.4)
17	1.06 (26.9)
18	1.13 (28.7)
19	1.19 (30.2)
20	1.25 (31.8)
21	1.31 (33.3)
22	1.38 (35.1)

**TABLE IV: BRAID TYPE**

Symbol	Braid Type
A	100% AmberStrand®
B	75%/25% AmberStrand® Blend
L	100% ArmorLite™
Standard	Nickel/Copper 34awg
T	Tin/Copper 34awg

A

1. After terminating shields, tighten the backshell to the connector and build-up the outside diameter of the wire bundle with AS85049/127 bushing strip to achieve a moderately snug fit against the saddle-bars.
2. Position the saddle-bars on the built-up wire bundle. Then, using Glenair TG69 Soft Jaw pliers, hold the saddle-bars down firmly and evenly against the wire bundle. (See figure 1)
3. Continuing to hold down the saddle bars, tighten clamp screws. Alternate between insertion of both screws so that the saddle bars compress against the cable evenly. Stop when the saddle-bars bottom against the arms of the clamp assembly. (See figure 2)
4. Tighten screws to correct torque values



### Saddle Clamp Torque Specifications

Saddle Screw Size	Installation Torque (In/Lbs)
4	4
6	6
10	10

# The Right Backshell for the Job...



## ...and the Right Tool for the Job

**G**lenair recommends the use of the appropriate sized series 600-157 or series 600-091 composite hex coupling wrench to prevent damage to the composite backshell coupling nut. The wrench is used during assembly of the backshell to the rear end of the connector.

The use of incorrect types and styles of coupling nut wrenches, such as slip-jaw pliers, will result in damage to the composite coupling nut up to and including failure due to cracking. So don't do it. You picked the right backshell, now pick up the right tool.



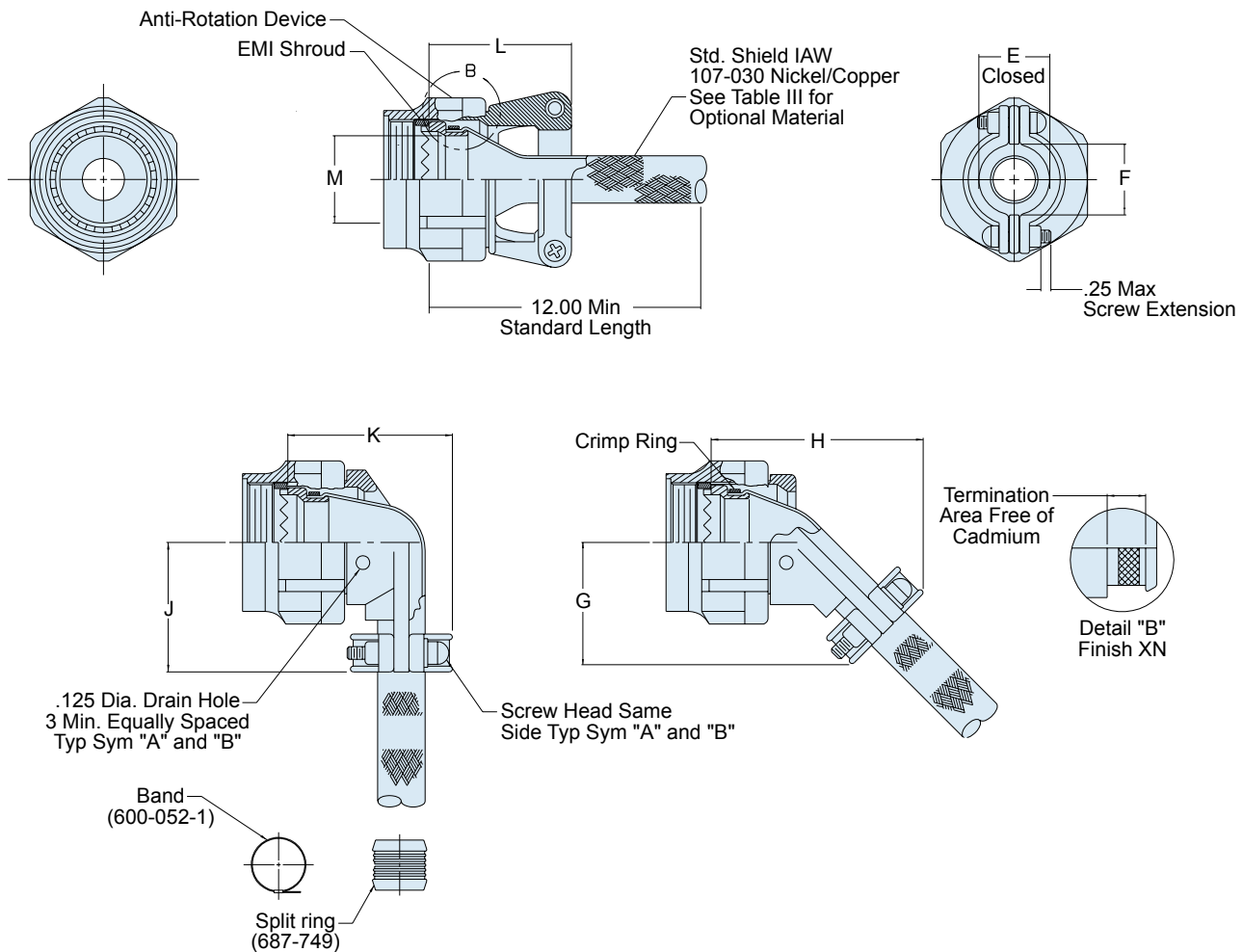
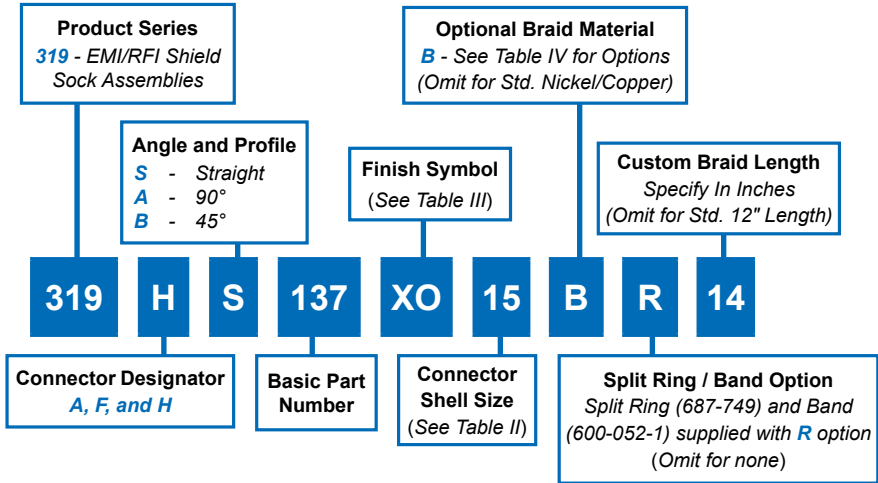
1211 Air Way  
Glendale, California 91201-2497  
Telephone: 818-247-6000 · Facsimilie: 818-500-9912 · EMail: sales@glenair.com

United States • United Kingdom • England • Nordic • France • Italy • Spain • Japan  
www.glenair.com

# 319-137 Composite Shield Sock Strain Relief with Self-Locking Rotatable Coupling

A

CONNECTOR DESIGNATOR:	
<b>A</b>	MIL-DTL-5015, -26482 Series II, and -83723 Series I and III
<b>F</b>	MIL-DTL-38999 Series I, II (see note 3)
<b>H</b>	MIL-DTL-38999 Series III and IV
<b>SELF-LOCKING</b>	
<b>ROTATABLE COUPLING</b>	
<b>LOW PROFILE</b>	



# 319-137 Composite Shield Sock Strain Relief with Self-Locking Rotatable Coupling



Composite  
Backshells

A

TABLE II: SHELL SIZE

Shell Size		E ± .031	F Min	G Max	H Max
A, F	H				
08	09	.265 (6.7)	.22 (5.6)	.901 (22.9)	1.388 (35.3)
10	11	.310 (7.9)	.27 (6.9)	.964 (24.5)	1.428 (36.3)
12	13	.390 (9.9)	.35 (8.9)	1.050 (26.7)	1.498 (38.0)
14	15	.506 (12.9)	.47 (11.9)	1.112 (28.2)	1.548 (39.3)
16	17	.591 (15.0)	.55 (14.0)	1.175 (29.8)	1.648 (41.9)
18	19	.661 (16.8)	.62 (15.7)	1.230 (31.2)	1.768 (44.9)
20	21	.744 (18.9)	.70 (17.8)	1.293 (32.8)	1.808 (45.9)
22	23	.826 (21.0)	.78 (19.8)	1.365 (34.7)	1.858 (47.2)
24	25	.896 (22.8)	.85 (21.6)	1.417 (36.0)	1.898 (48.2)

TABLE II: SHELL SIZE (CONTINUED)

Shell Size		J Max	K Max	L Max	K Diameter		
A, F	H				A Code	F Code	H Code
08	09	.91 (23.1)	1.128 (28.7)	.939 (23.9)	.265 (6.7)	.275 (7.0)	.264 (6.7)
10	11	.97 (24.6)	1.168 (29.7)	1.059 (26.9)	.370 (9.4)	.412 (10.5)	.390 (9.9)
12	13	1.06 (26.9)	1.248 (31.7)	1.199 (30.5)	.506 (12.9)	.526 (13.4)	.504 (12.8)
14	15	1.16 (29.5)	1.368 (34.7)	1.199 (30.5)	.580 (14.7)	.651 (16.5)	.630 (16.0)
16	17	1.34 (34.0)	1.448 (36.8)	1.329 (33.8)	.705 (17.9)	.776 (19.7)	.756 (19.2)
18	19	1.41 (35.8)	1.528 (38.8)	1.509 (38.3)	.784 (19.9)	.872 (22.1)	.843 (21.4)
20	21	1.53 (38.9)	1.648 (41.9)	1.609 (40.9)	.909 (23.1)	1.007 (25.6)	.969 (24.6)
22	23	1.66 (42.2)	1.688 (42.9)	1.759 (44.7)	1.034 (1.034)	1.132 (28.8)	1.091 (27.7)
24	25	1.78 (45.2)	1.758 (44.7)	1.859 (47.2)	1.149 (29.2)	1.257 (31.9)	1.217 (30.9)

TABLE III: FINISH

Symbol	Finish
<b>XB</b>	Composite Material—No Plating, Color Black, Brass Interface Shroud and Adapter—Nickel Plated
<b>XMT</b>	2000 Hour Corrosion Resistant Ni-PTFE, Nickel-Fluorocarbon Polymer. 1000 Hour Grey™
<b>XN</b>	Composite Material—No Plating, Color Black and Brown, Brass Interface Shroud and Adapter—Selectively Cadmium Plated (See Detail B)

TABLE IV: BRAID TYPE

Symbol	Braid Type
A	100% AmberStrand®
B	75%/25% AmberStrand® Blend
L	100% ArmorLite™
Standard	Nickel/Copper 34awg
T	Tin/Copper 34awg

## NOTES

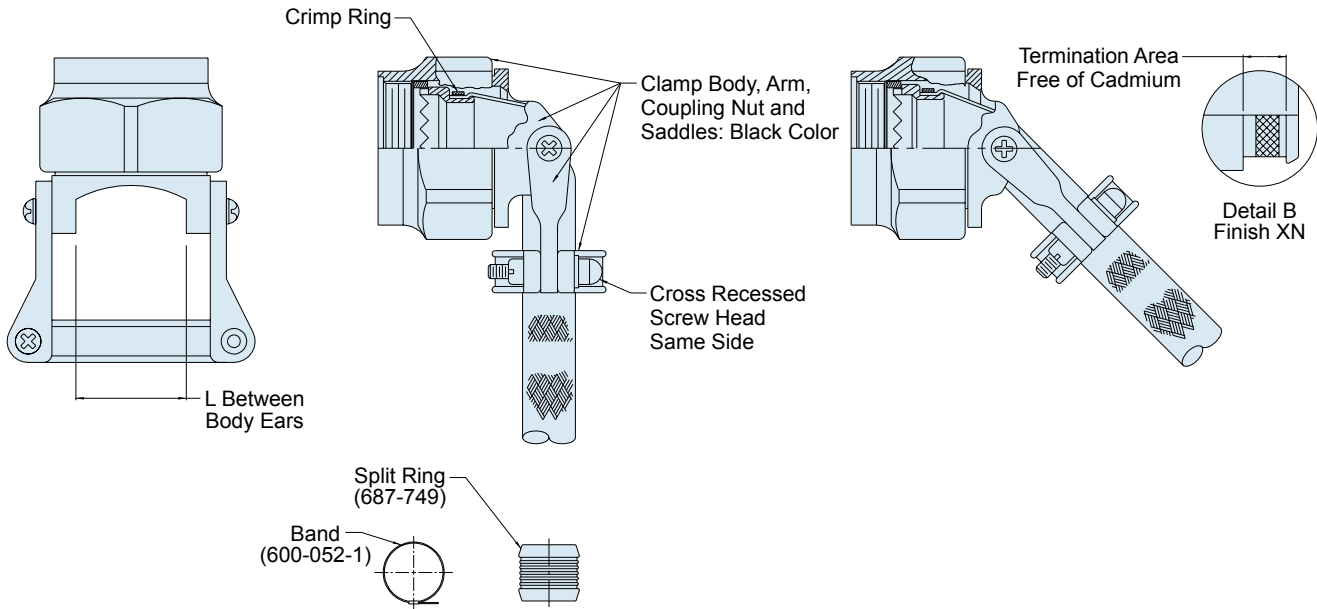
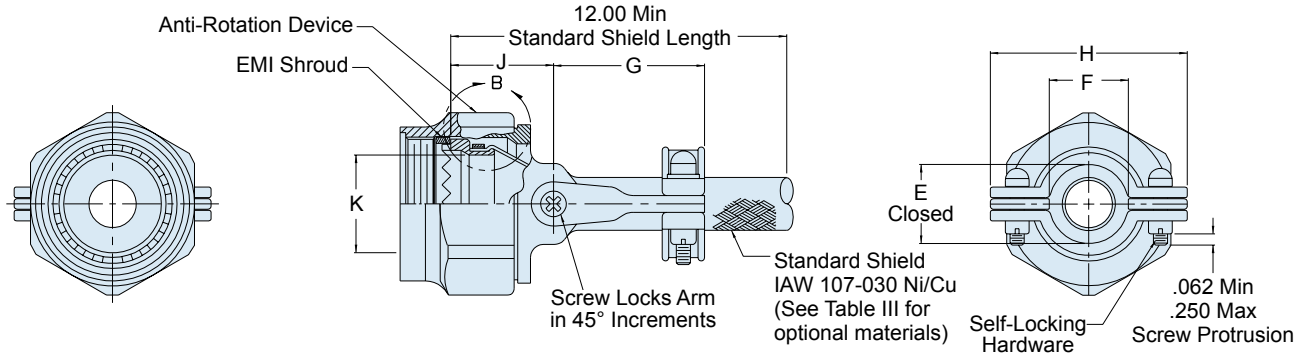
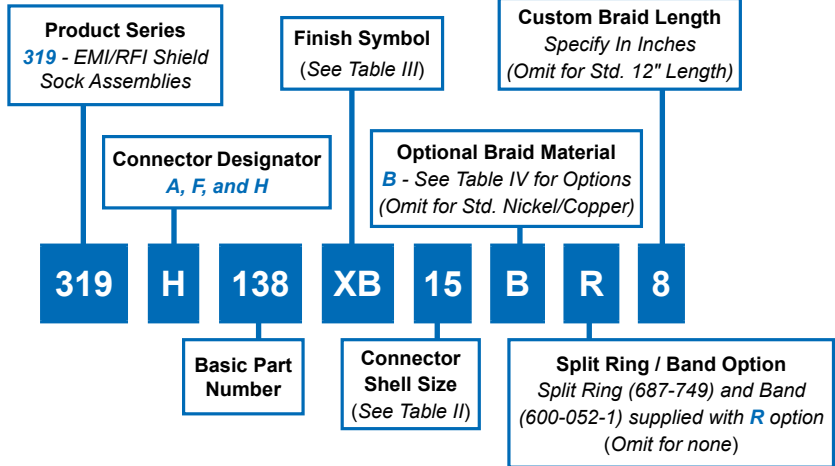
1. See composite thermoplastic shield sock assembly procedure for detailed installation instructions.
2. See Table I in Intro for front-end dimensional details.
3. Add mod code -475 to end of part number for use with Series II connectors. Backshell to be supplied less shroud.
4. Coupling nut supplied unplated.



# 319-138 "Wide Mouth" Composite Swing-Arm Strain Relief with Shield Sock and Self-Locking Rotatable Coupling

A

CONNECTOR DESIGNATOR:	
<b>A</b>	MIL-DTL-5015, -26482 Series II, and -83723 Series I and III
<b>F</b>	MIL-DTL-38999 Series I, for Series II See Note 3
<b>H</b>	MIL-DTL-38999 Series III and IV
<b>SELF-LOCKING</b>	
<b>ROTATABLE COUPLING</b>	
<b>LOW PROFILE</b>	



**319-138**  
**"Wide Mouth" Composite Swing-Arm Strain Relief**  
 with Shield Sock and  
 Self-Locking Rotatable Coupling



Composite Backshells

**TABLE II: SHELL SIZE**

Shell Size		E ± .031	F Min	G Max ± .06	H ± .060	J Max	L Max	K Diameter		
A, F	H							A Code	F Code	H Code
08	09	.350 (8.9)	.350 (8.9)	1.045 (26.5)	.936 (23.8)	.94 (23.9)	.393 (10.0)	.265 (6.7)	.275 (7.0)	.264 (6.7)
10	11	.436 (11.1)	.455 (11.6)	1.045 (26.5)	1.172 (29.8)	.97 (24.6)	.455 (11.6)	.370 (9.4)	.412 (10.5)	.390 (9.9)
12	13	.636 (16.2)	.640 (16.3)	1.170 (29.7)	1.406 (35.7)	1.03 (26.2)	.598 (15.2)	.506 (12.9)	.526 (13.4)	.504 (12.8)
14	15	.706 (17.9)	.710 (18.0)	1.170 (29.7)	1.500 (38.1)	1.09 (27.7)	.710 (18.0)	.580 (14.7)	.651 (16.5)	.630 (16.0)
16	17	.790 (20.1)	.835 (21.2)	1.295 (32.9)	1.562 (39.7)	1.12 (28.4)	.839 (21.3)	.705 (17.9)	.776 (19.7)	.756 (19.2)
18	19	.872 (22.1)	.922 (23.4)	1.295 (32.9)	1.687 (42.8)	1.15 (29.2)	.934 (23.7)	.784 (19.9)	.872 (22.1)	.843 (21.4)
20	21	.996 (25.3)	1.008 (25.6)	1.467 (39.5)	1.969 (50.0)	1.18 (30.0)	1.068 (27.1)	.909 (23.1)	1.007 (25.6)	.969 (24.6)
22	23	1.060 (26.9)	1.197 (30.4)	1.467 (39.5)	2.094 (53.2)	1.25 (31.8)	1.197 (30.4)	1.034 (1.034)	1.132 (28.8)	1.091 (27.7)
24	25	1.123 (28.5)	1.323 (33.6)	1.461 (37.1)	2.281 (57.9)	1.28 (32.5)	1.323 (33.6)	1.149 (29.2)	1.257 (31.9)	1.217 (30.9)

A

**TABLE III: FINISH**

Symbol	Finish
<b>XB</b>	Composite Material—No Plating, Color Black, Brass Interface Shroud and Adapter—Nickel Plated
<b>XMT</b>	2000 Hour Corrosion Resistant Ni-PTFE, Nickel-Fluorocarbon Polymer. <i>1000 Hour Grey™</i>
<b>XN</b>	Composite Material—No Plating, Color Black and Brown, Brass Interface Shroud and Adapter—Selectively Cadmium Plated (See Detail B)

**TABLE IV: BRAID TYPE**

Symbol	Braid Type
A	100% AmberStrand®
B	75%/25% AmberStrand® Blend
L	100% ArmorLite™
<i>Standard</i>	Nickel/Copper 34awg
T	Tin/Copper 34awg

**NOTES**

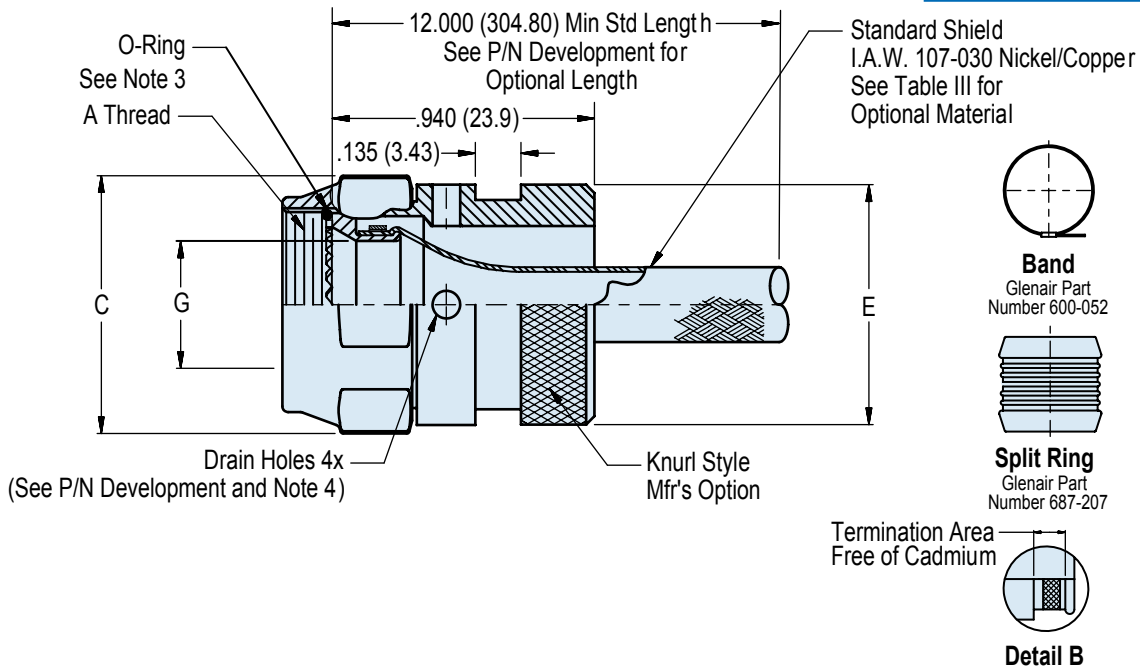
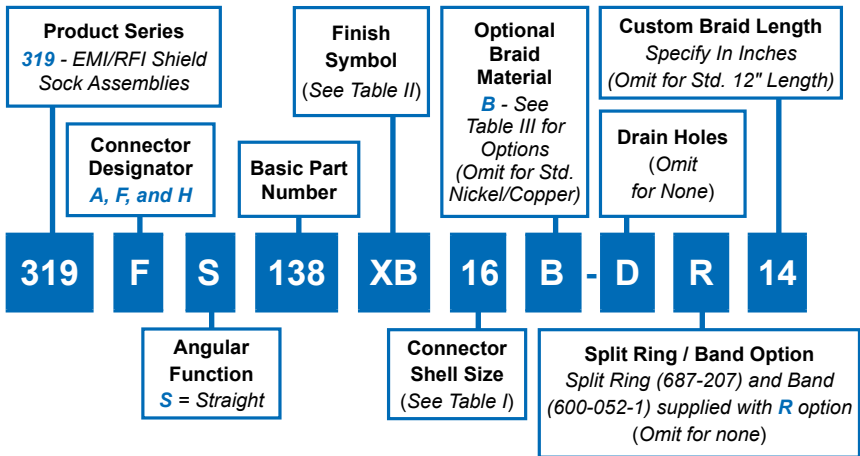
1. See Table I in Intro for front-end dimensional details.
2. See composite thermoplastic shield sock assembly procedure for detailed installation instructions.
3. Add mod code -475 to end of part number for use with Series II connectors. Backshell to be supplied less shroud.
4. Coupling nut supplied unplated.



# 319-155 RFI/EMI Composite Adapter with Shrink Boot, Split Ring, RFI/EMI Braided Shielding, Termination Porch and Stainless Steel Band

**A**

CONNECTOR DESIGNATOR:	
<b>A</b>	MIL-DTL-83723 Series III
<b>F</b>	MIL-DTL-38999 Series I, II
<b>H</b>	MIL-DTL-38999 Series III and IV
<b>SELF-LOCKING</b>	
<b>ROTATABLE COUPLING</b>	



- ### NOTES
- Assembly identified with manufacturer's name and part number, space permitting.
  - Glenair 600 Series Backshell Assembly Tools are recommended for assembly and installation.
  - O-Ring supplied with connector designator F & H only. O-Ring is not supplied with connector designator A or with drain hole option.
  - Material/Finish:  
 Coupling Nut, Adapter and Split Ring – High temperature engineering thermoplastic/See Table II.  
 Follower – Brass/Electroless nickel.  
 O-Ring – Fluorosilicone/NA.  
 Shrink Boot – See 770-001S\*\* Shrink Boot product page for details.  
 Termination Band – SST/Passivated.  
 Crimp Ring – Copper/Tin plated.  
 Braid – See Table III.



**319-155**  
**RFI/EMI Composite Adapter**  
 with Shrink Boot, Split Ring, RFI/EMI Braided Shielding,  
 Termination Porch and Stainless Steel Band



Composite Backshells

A

**TABLE I: SHELL SIZE (Continued Below)**

CONNECTOR DESIGNATOR A			CONNECTOR DESIGNATOR F			CONNECTOR DESIGNATOR H			B Dia Ref.
Dash No.	Shell Size Ref.	A Thread Class 2B	Dash No.	Shell Size Ref.	A Thread Class 2 B	Dash No.		A Thread ISO Metric	
08	08	1/2-20 UNF	08	08	7/16-28 UNEF	09	A	M12 X 1.0-6H	.812 (20.6)
10	10	5/8-24 UNEF	10	10	9/16-24 UNEF	11	B	M15 X 1.0-6H	.938 (23.8)
12	12	3/4-20 UNEF	12	12	11/16-24 UNEF	13	C	M18 X 1.0-6H	1.125 (28.6)
14	14	7/8-20 UNEF	14	14	13/16-20 UNEF	15	D	M22 X 1.0-6H	1.250 (31.8)
16	16	1-20 UNEF	16	16	15/16-20 UNEF	17	E	M25 X 1.0-6H	1.375 (34.9)
18	18	1 1/16-18 UNEF	18	18	1 1/16-18 UNEF	19	F	M28 X 1.0-6H	1.500 (38.1)
20	20	1 3/16-18 UNEF	20	20	1 3/16-18 UNEF	21	G	M31 X 1.0-6H	1.625 (41.3)
22	22	1 5/16-18 UNEF	22	22	1 5/16-18 UNEF	23	H	M34 X 1.0-6H	1.750 (44.5)
24	24	1 7/16-18 UNEF	24	24	1 7/16-18 UNEF	25	J	M34 X 1.0-6H	1.875 (47.6)

**TABLE I: SHELL SIZE (Continued from Above)**

Dash No.	C Flats		E Max	G Dia		Shrink Boot
	Max	Min		Code H & F	Code A	
08	.750 (19.1)	.736 (18.7)	.533 (13.5)	.264 (6.7)	.265 (6.7)	770-003S102
10	.875 (22.2)	.860 (21.8)	.605 (15.4)	.390 (9.9)	.370 (9.4)	770-001S103
12	1.000 (25.4)	.980 (24.9)	.774 (19.7)	.504 (12.8)	.506 (12.9)	770-001S103
14	1.125 (28.6)	1.100 (27.9)	.838 (21.3)	.630 (16.0)	.580 (14.7)	770-001S103
16	1.250 (31.8)	1.224 (31.1)	.963 (24.5)	.756 (19.2)	.705 (17.9)	770-001S104
18	1.375 (34.9)	1.348 (34.2)	1.042 (26.5)	.843 (21.4)	.784 (19.9)	770-001S104
20	1.500 (38.1)	1.469 (37.3)	1.217 (30.9)	.969 (24.6)	.907 (23.0)	770-001S106
22	1.625 (41.3)	1.581 (40.2)	1.355 (34.4)	1.091 (27.7)	1.034 (26.3)	770-001S107
24	1.750 (44.5)	1.690 (42.9)	1.443 (36.7)	1.213 (30.8)	1.140 (28.9)	770-001S107

**TABLE II: FINISH**

Symbol	Finish
<b>XB</b>	No Plating, Black Material
<b>XD</b>	No Plating, Desert Tan

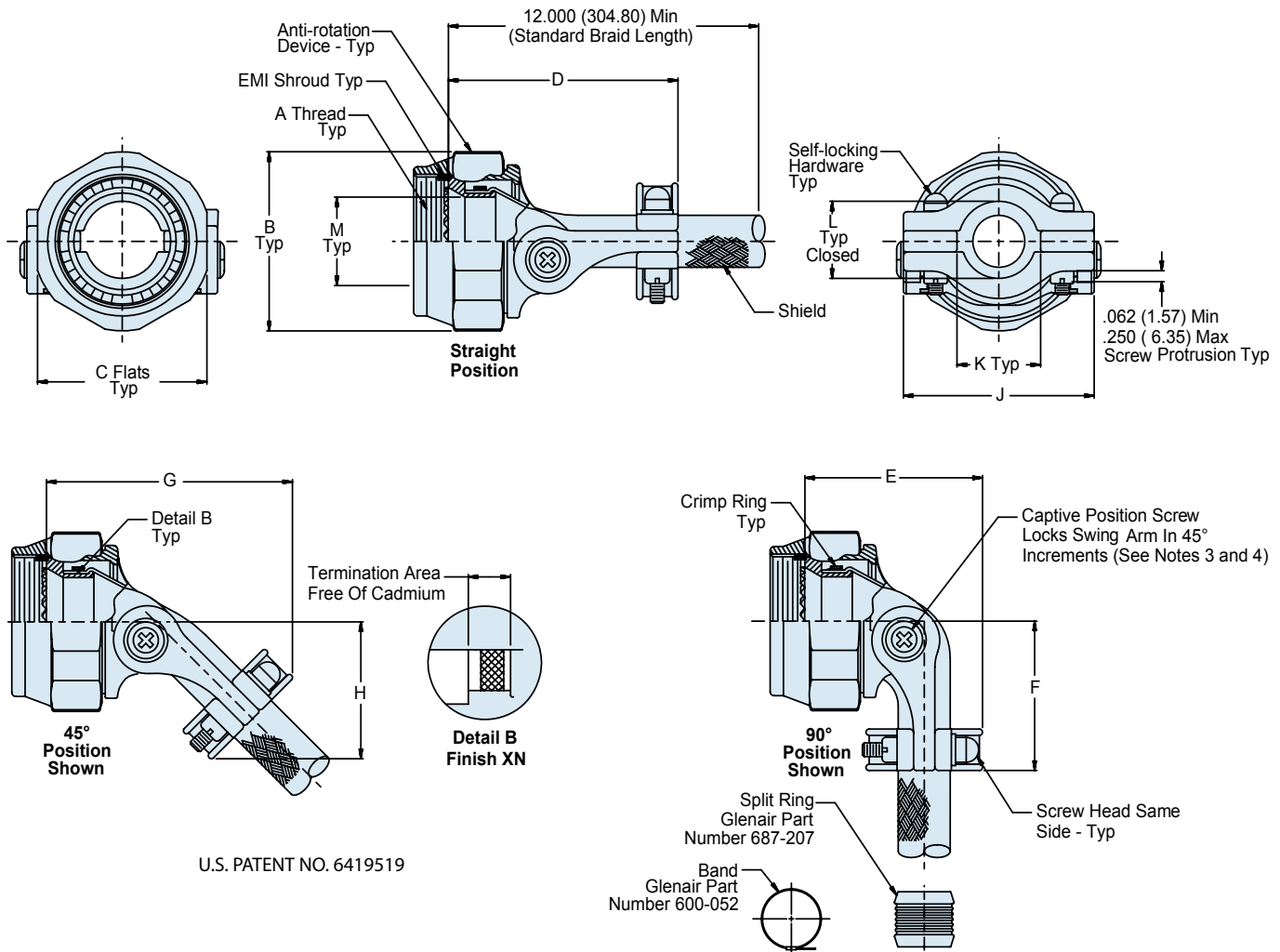
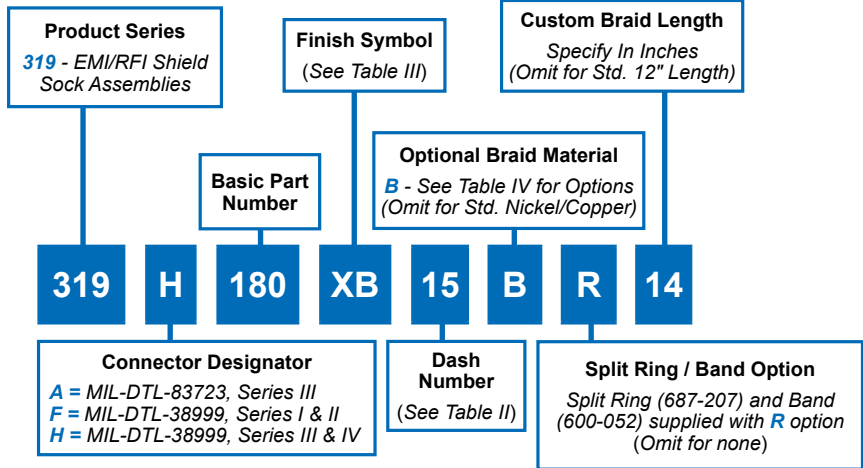
**TABLE III: BRAID TYPE**

Symbol	Braid Type
<b>A</b>	100% AmberStrand®
<b>B</b>	75%/25% AmberStrand® Blend
<i>Standard</i>	Nickel/Copper 34 AWG
<b>T</b>	Tin/Copper 34 AWG
<b>L</b>	100% ArmorLite™

# 319-180 Composite Swing-Arm Strain Relief with Shield Sock and Self-Locking Rotatable Coupling

A

CONNECTOR DESIGNATOR:	
<b>A</b>	MIL-DTL-83723, Series III
<b>F</b>	MIL-DTL-38999 Series I, II
<b>H</b>	MIL-DTL-38999 Series III and IV
<b>SELF-LOCKING</b>	
<b>ROTATABLE COUPLING</b>	



U.S. PATENT NO. 6419519

# 319-180

## Composite Swing-Arm Strain Relief with Shield Sock and Self-Locking Rotatable Coupling



**TABLE II: SHELL SIZE (Continued Below)**

Connector Designator A			Connector Designator F*			Connector Designator H			B Max Dia	C Flats		D Max	E Max	F Max
Dash No.	Shell Size Ref	A Thread Class 2 B	Dash No.	Shell Size Ref	A Thread Class 2 B	Dash No.	Shell Size Ref	A Thread ISO Metric		Max	Min			
08	08	1/2-20 UNF	08	08	7/16-28 UNF	09	A	M12 X 1.0-6H	.812 (20.62)	.750 (19.05)	.736 (18.69)	1.500 (38.10)	.950 (24.13)	.840 (21.34)
10	10	5/8-24 UNEF	10	10	9/16-24 UNEF	11	B	M15 X 1.0-6H	.938 (23.83)	.875 (22.23)	.860 (21.84)	1.540 (39.12)	.990 (25.15)	.900 (22.86)
12	12	3/4-20 UNEF	12	12	11/16-24 UNEF	13	C	M18 X 1.0-6H	1.125 (28.58)	1.000 (25.40)	.980 (24.89)	1.620 (41.15)	1.140 (28.96)	1.000 (25.40)
14	14	7/8-20 UNEF	14	14	13/16-20 UNEF	15	D	M22 X 1.0-6H	1.250 (31.75)	1.125 (28.58)	1.100 (27.94)	1.630 (41.40)	1.240 (31.50)	1.070 (27.18)
16	16	1-20 UNEF	16	16	15/16-20 UNEF	17	E	M25 X 1.0-6H	1.375 (34.93)	1.250 (31.75)	1.224 (31.09)	1.730 (43.94)	1.360 (34.54)	1.130 (28.70)
18	18	1 1/16-18 UNEF	18	18	1 1/16-18 UNEF	19	F	M28 X 1.0-6H	1.500 (38.10)	1.375 (34.93)	1.348 (34.24)	1.730 (43.94)	1.460 (37.08)	1.200 (30.48)
20	20	1 3/16-18 UNEF	20	20	1 3/16-18 UNEF	21	G	M31 X 1.0-6H	1.625 (41.28)	1.500 (38.10)	1.469 (37.31)	1.880 (47.75)	1.550 (39.37)	1.260 (32.00)
22	22	1 5/16-18 UNEF	22	22	1 5/16-18 UNEF	23	H	M34 X 1.0-6H	1.750 (44.45)	1.625 (41.28)	1.581 (40.16)	1.910 (48.51)	1.630 (41.40)	1.330 (33.78)
24	24	1 7/16-18 UNEF	24	24	1 7/16-18 UNEF	25	J	M37 X 1.0-6H	1.875 (47.63)	1.750 (44.45)	1.690 (42.93)	1.940 (49.28)	1.700 (43.18)	1.400 (35.56)

\* See Note 6

**TABLE II: SHELL SIZE (Continued from Above)**

G Max	H Max	J Max	K Min	L Max	M Min
1.430 (36.32)	.760 (19.30)	.980 (24.89)	.220 (5.59)	.265 (6.73)	.264 (6.71)
1.490 (37.85)	.820 (20.83)	1.050 (26.67)	.270 (6.86)	.310 (7.87)	.390 (9.91)
1.640 (41.66)	.920 (23.37)	1.200 (30.48)	.350 (8.89)	.390 (9.91)	.504 (12.80)
1.730 (43.94)	.980 (24.89)	1.300 (33.02)	.470 (11.94)	.506 (12.85)	.630 (16.00)
1.860 (47.24)	1.080 (27.43)	1.440 (36.58)	.550 (13.97)	.591 (15.01)	.756 (19.20)
1.930 (49.02)	1.120 (28.45)	1.560 (39.62)	.620 (15.75)	.661 (16.79)	.843 (21.41)
2.080 (52.95)	1.210 (30.73)	1.690 (42.93)	.700 (17.78)	.744 (18.90)	.969 (24.61)
2.150 (54.61)	1.270 (32.26)	1.770 (44.96)	.780 (19.81)	.826 (20.98)	1.091 (27.71)
2.230 (56.64)	1.330 (33.78)	1.890 (48.01)	.850 (21.59)	.896 (22.76)	1.217 (30.91)

**TABLE III: FINISH**

Symbol	Finish
<b>XB</b>	Composite Material—No Plating, Color Black, Brass Interface Shroud and Adapter—Nickel Plated
<b>XMT</b>	2000 Hour Corrosion Resistant Ni-PTFE, Nickel-Fluorocarbon Polymer. <i>1000 Hour Grey™</i>
<b>XN</b>	Composite Material—No Plating, Color Black and Brown, Brass Interface Shroud and Adapter—Selectively Cadmium Plated (See Detail B)

**TABLE IV: BRAID TYPE**

Symbol	Braid Type
A	100% AmberStrand®
B	75%/25% AmberStrand® Blend
L	100% ArmorLite™
<i>Standard</i>	Nickel/Copper 34awg
T	Tin/Copper 34awg

**NOTES**

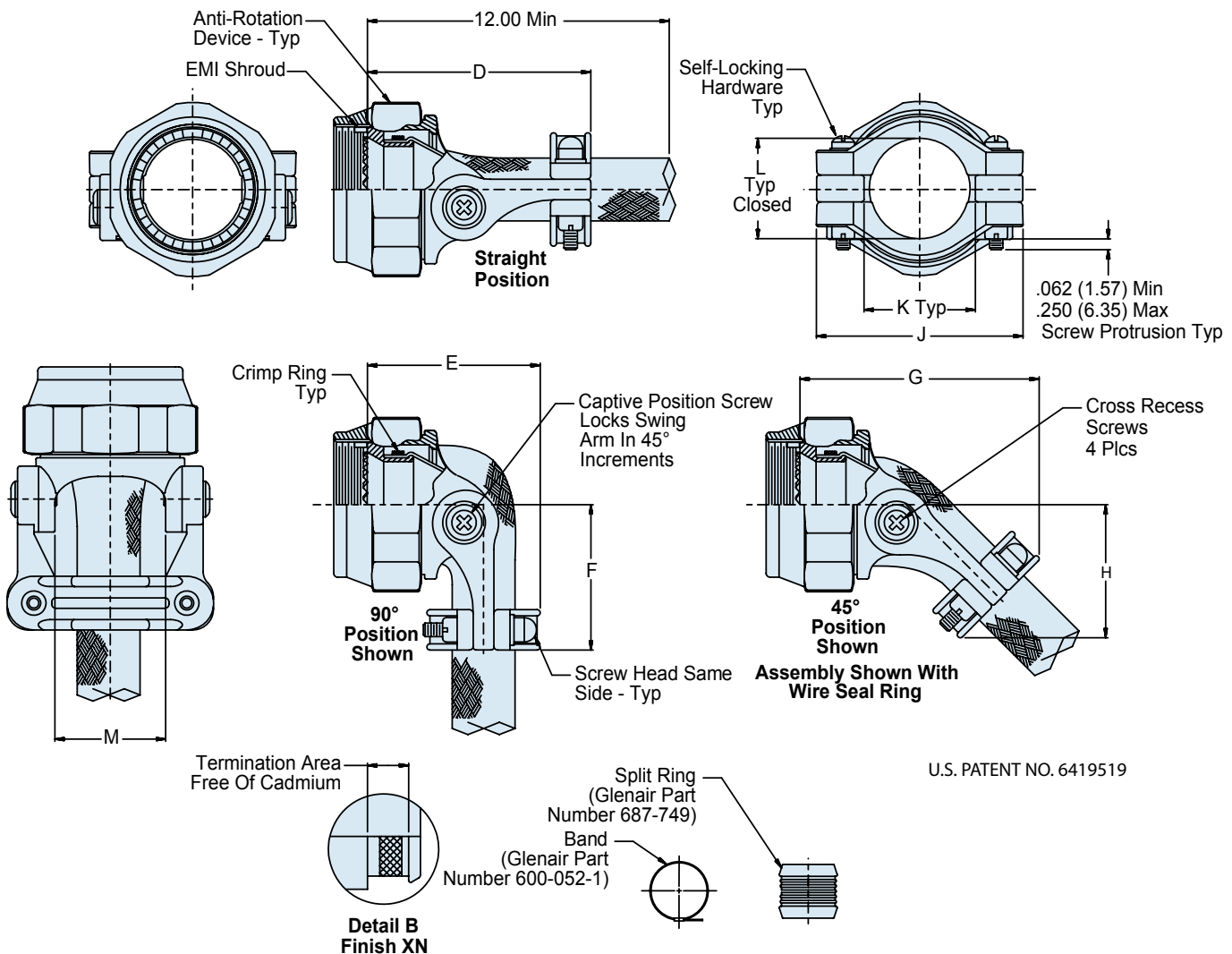
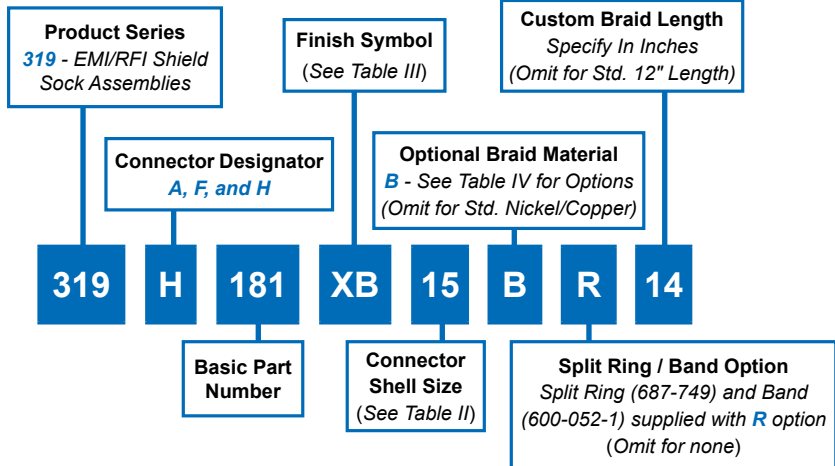
1. See Table I in Intro for front-end dimensional details.
2. Glenair Series 600 Assembly Tools are recommended for assembly and installation.
3. Swing arm locks in 45° increments, shell size 09 through 25. Additional positioning increments are manufacturer's option.
4. Screw is captive to the arm when disengaged. When tightened, the screw will not protrude into the inside surfaces.
5. Material/Finish:  
 Clamp body, coupling nut, saddles - High grade thermoplastic/See Table III.  
 Clamp hardware - CRES/Passivate  
 Shield - See Table IV.  
 Interface ring and shroud - Table III.  
 Crimp ring - Copper/Tin plated.
6. Add MOD Code -475 to end of part number for use with Series II connector. Backshell to be supplied less shroud.
7. Metric dimensions (mm) indicated in parentheses.



# 319-181 "Wide Mouth" Composite Low-Profile Swing-Arm Strain Relief with Shield Sock and Self-Locking Rotatable Coupling

A

CONNECTOR DESIGNATOR:	
<b>A</b>	MIL-DTL-5015, -26482 Series II, and -83723 Series I and III
<b>F</b>	MIL-DTL-38999 Series I, for Series II See Note 8
<b>H</b>	MIL-DTL-38999 Series III and IV
<b>SELF-LOCKING</b>	
<b>ROTATABLE COUPLING</b>	
<b>LOW PROFILE</b>	



# 319-181 "Wide Mouth" Composite Low-Profile Swing-Arm Strain Relief with Shield Sock and Self-Locking Rotatable Coupling



**TABLE II: SHELL SIZE (Continued Below)**

Shell Size		D Max	E Max	F ± .03 (0.76)	G Max	H Max	J ± .03 (0.76)	K Min	L Ref	M Wire Bundle Dimension Between Ears Ref
A, F	H									
08	09	1.510 (38.35)	.980 (24.89)	.800 (2.32)	1.460 (37.08)	.780 (19.81)	.936 (23.77)	.350 (8.89)	.310 (7.87)	.393 (9.98)
10	11	1.580 (40.13)	1.050 (26.67)	.900 (22.86)	1.570 (39.88)	.870 (22.10)	1.172 (29.77)	.455 (11.56)	.375 (9.53)	.455 (11.56)
12	13	1.640 (41.66)	1.290 (32.77)	.970 (24.64)	1.760 (44.70)	1.020 (25.91)	1.406 (35.71)	.640 (16.26)	.591 (15.01)	.598 (15.19)
14	15	1.650 (41.91)	1.370 (34.80)	1.030 (25.75)	1.820 (46.23)	1.060 (26.92)	1.500 (38.10)	.710 (18.03)	.661 (16.79)	.710 (18.03)
16	17	1.740 (44.20)	1.440 (36.58)	1.100 (27.50)	1.920 (48.77)	.839 (21.31)	1.562 (39.67)	.839 (21.31)	.713 (18.11)	.839 (21.31)
18	19	1.740 (44.20)	1.540 (39.12)	1.160 (29.46)	2.000 (50.80)	1.160 (29.46)	1.687 (42.85)	.922 (23.42)	.795 (20.19)	.934 (23.72)
20	21	1.890 (48.01)	1.690 (42.93)	1.230 (31.24)	2.180 (55.37)	1.290 (32.77)	1.912 (48.56)	1.068 (27.13)	.996 (25.30)	1.068 (27.13)
22	23	1.920 (48.77)	1.760 (44.70)	1.300 (33.02)	2.250 (57.15)	1.350 (34.29)	2.036 (51.71)	1.197 (30.40)	1.060 (26.92)	1.197 (30.40)
24	25	2.080 (52.83)	1.790 (45.47)	1.490 (37.85)	2.390 (60.71)	1.470 (37.34)	2.281 (57.94)	1.323 (33.60)	1.123 (28.52)	1.323 (33.60)

**TABLE III: FINISH**

Symbol	Finish
<b>XB</b>	Composite Material—No Plating, Color Black, Brass Interface Shroud and Adapter—Nickel Plated
<b>XMT</b>	2000 Hour Corrosion Resistant Ni-PTFE, Nickel-Fluorocarbon Polymer. <i>1000 Hour Grey™</i>
<b>XN</b>	Composite Material—No Plating, Color Black and Brown, Brass Interface Shroud and Adapter—Selectively Cadmium Plated (See Detail B)

**TABLE IV: BRAID TYPE**

Symbol	Braid Type
A	100% AmberStrand®
B	75%/25% AmberStrand® Blend
L	100% ArmorLite™
<i>Standard</i>	Nickel/Copper 34awg
T	Tin/Copper 34awg

## NOTES

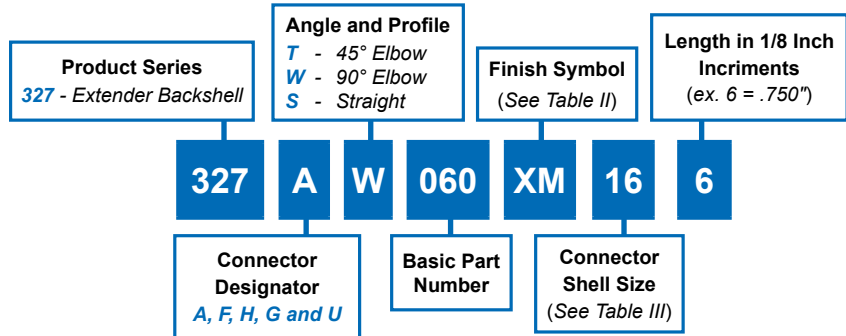
- See Table I in Intro for front-end dimensional details.
- Metric dimensions (mm) are in parentheses.
- See composite thermoplastic shield sock assembly procedure for detailed installation instructions.
- Coupling nut supplied unplated.
- Glenair Series 600 Assembly Tools are recommended for installation.
- Swing arm locks in 45° increments, shell size 09 through 25. Additional positioning increments are manufacturer's option.
- Screw is captive to the body when disengaged. When tightened, the screw will not protrude into the surface.
- Clamps accommodate MIL-DTL-38999, Series I, II, III and IV connectors, interface IAW AS85049, Figure 3. Add mod code -475 to end of part number for use with Series II connectors. Backshell to be supplied less shroud.
- Material/Finish:  
 Clamp body, coupling nut, saddles - High grade engineering thermoplastic/See Table III.  
 Clamp hardware - CRES/Passivate  
 Adapter (EMI/RFI) - Brass/Table III.  
 Anti-rotation device - Corrosion resistant material.  
 Shield - Copper/Nickel plate.  
 Interface ring and shroud - Table III.  
 Crimp ring - Copper/Tin plated.



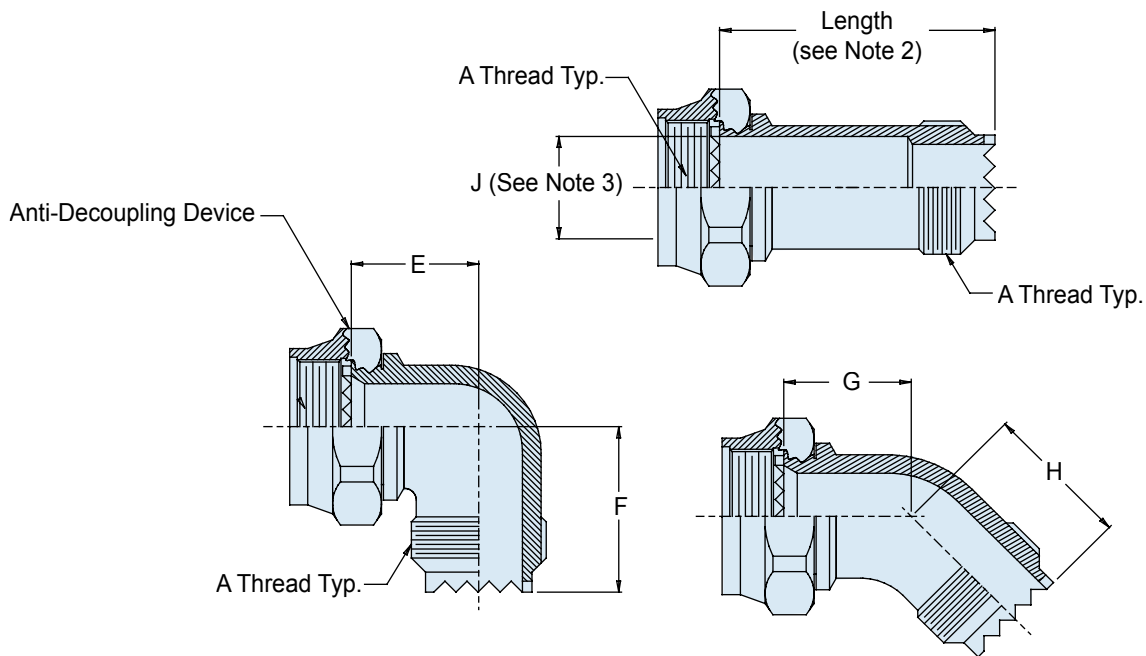
# 327-060 Extender Backshell with Self-Locking Rotatable Coupling

A

CONNECTOR DESIGNATOR:	
<b>A</b>	MIL-DTL-5015, -26482 Series II, and -83723 Series I and III
<b>F</b>	MIL-DTL-38999 Series I, II
<b>H</b>	MIL-DTL-38999 Series III and IV
<b>G</b>	MIL-DTL-28840
<b>U</b>	DG123 and DG123A
<b>SELF-LOCKING</b>	
<b>ROTATABLE COUPLING</b>	
<b>STANDARD PROFILE</b>	



**Note:** See Table I in Intro for Front-End Dimensional Details



### APPLICATION NOTES

1. Metric dimensions (mm) are in parentheses and are for reference only.
2. Available length, straight configuration only, 6 = .750 (19.1), 8 = 1.00 (25.4), consult factory for additional length. Omit length designator for angular functions.
3. J Diameter applicable to connector Code H, straight configuration only.
4. Coupling nut supplied unplated.
5. See Table I in Intro for front-end dimensional details.

**327-060**  
**Extender Backshell**  
 with Self-Locking Rotatable Coupling



**TABLE II: FINISH**

Symbol	Finish Description
XM	2000 Hour Corrosion Resistant Electroless Nickel
XMT	2000 Hour Corrosion Resistant Ni-PTFE, Nickel-Fluorocarbon Polymer. <i>1000 Hour Grey™</i>
XO	No Plating - Brown Color (Non-Conductive Finish)
XB	No Plating - Black Color (Non-Conductive Finish)
XW	2000 Hour Corrosion Resistant Cadmium/Olive Drab over Electroless Nickel

**TABLE III: CONNECTOR SHELL SIZE ORDER NUMBER**

Shell Size For Connector Designator		E		F		G		H	
A, F	H	Max		Max		Max		Max	
08	09	.74	(18.8)	1.00	(25.4)	.78	(19.8)	.89	(22.6)
10	11	.80	(20.3)	1.06	(26.9)	.81	(20.6)	.92	(23.4)
12	13	.86	(21.8)	1.12	(28.4)	.81	(20.6)	.94	(23.9)
14	15	.93	(23.6)	1.19	(30.2)	.82	(20.8)	.97	(24.6)
16	17	.99	(25.1)	1.25	(31.8)	.84	(21.3)	.99	(25.1)
18	19	1.05	(26.7)	1.31	(33.3)	.85	(21.6)	1.00	(25.4)
20	21	1.12	(28.4)	1.38	(35.1)	.88	(22.4)	1.03	(26.2)
22	23	1.18	(30.0)	1.44	(36.6)	.92	(23.4)	1.07	(27.2)
24	25	1.24	(31.5)	1.50	(38.1)	.97	(24.6)	1.08	(27.4)

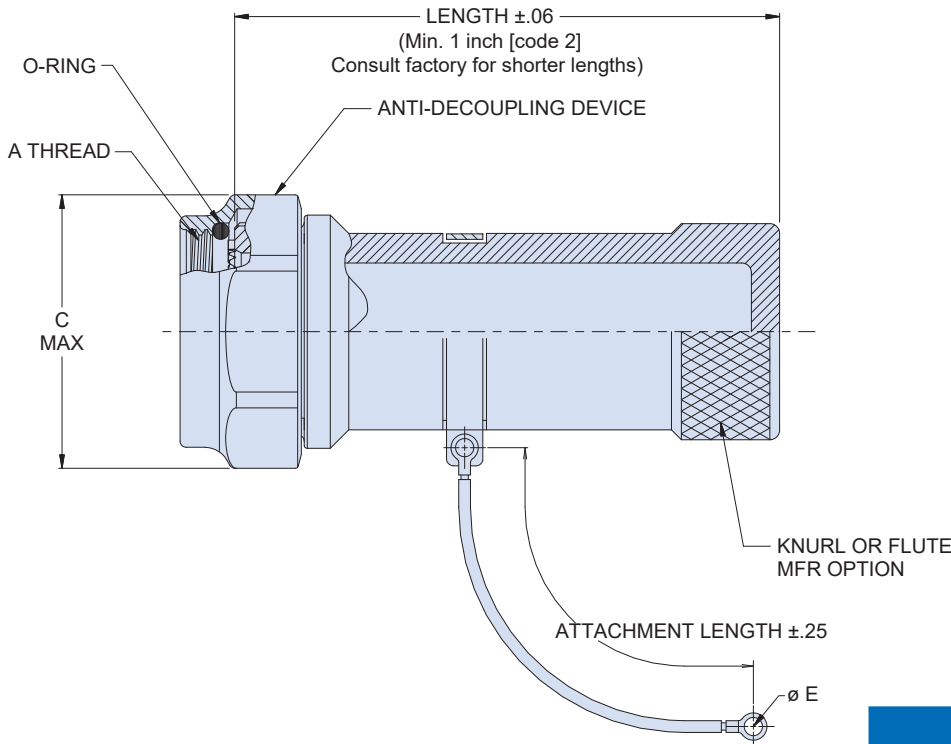
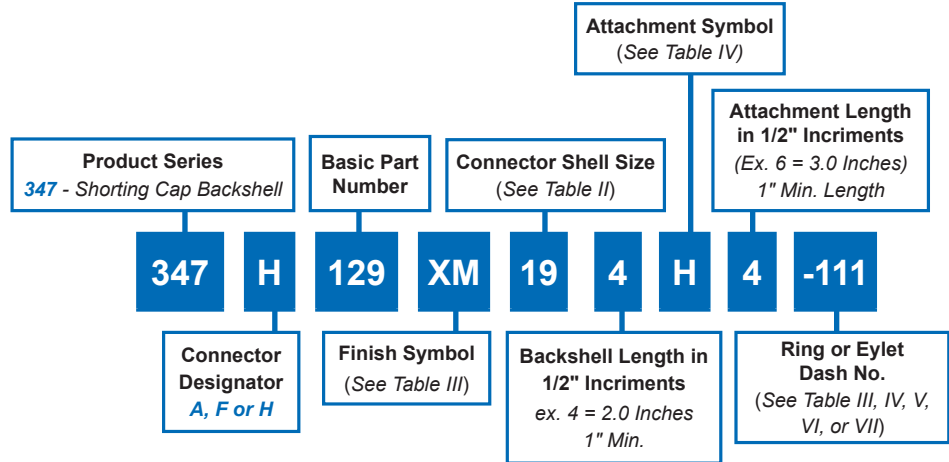


# 347-129 Composite Shorting Cap Backshell with Lanyard Attachment and Self-Locking Rotatable Coupling

A

CONNECTOR DESIGNATOR:	
<b>A</b>	MIL-DTL-5015, -26482 Series II, and -83723 Series I and III
<b>F</b>	MIL-DTL-38999 Series I, II
<b>H</b>	MIL-DTL-38999 Series III and IV
<b>SELF-LOCKING</b>	
<b>ROTATABLE COUPLING</b>	

Note: See Table I in Intro for Front-End Dimensional Details



A, F	H
08	09
10	11
12	13
14	15
16	17
18	19
20	21
22	23
24	25

Symbol	Finish Description
XM	2000 Hour Corrosion-Resistant Electroless Nickel
XMT	2000 Hour Corrosion Resistant Ni-PTFE, Nickel-Fluorocarbon Polymer. 1000 Hour Grey™
XW	2000 Hour Corrosion Resistant Cadmium Olive Drab Over Electroless Nickel

1.	Coupling nut supplied unplated.
2.	See Table I in Intro for front-end dimensional details.

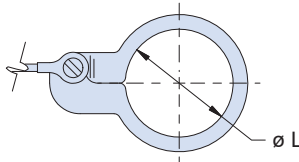


# 347-129 Composite Shorting Cap Backshell with Lanyard Attachment and Self-Locking Rotatable Coupling

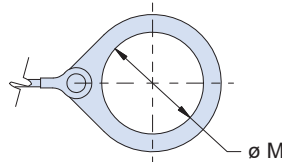


Symbol	Attachment
C	No Attachment, Body Strap Only
D	Bead Chain, CRES/Passivate with Terminal
F	Wire Rope, Nylon Jacket with Terminal
G	Nylon Rope with Terminal
H	Wire Rope, Teflon Jacket with Terminal
N	Attachment Omitted
R	Wire Rope, PVC Jacket with Terminal
S	#8 Sash Chain, CRES/Passivate
U	Wire Rope, Polyurethane Jacket with Terminal

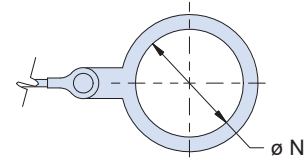
Dash No.	E Diameter
01	.140 (3.6)
02	.182 (4.6)
03	.191 (4.9)
04	.197 (5.0)
05	.167 (4.2)
06	.125 (3.2)
07	.218 (5.5)
09	.156 (4.0)



SPLIT RING



SOLID RING



SOLID RING

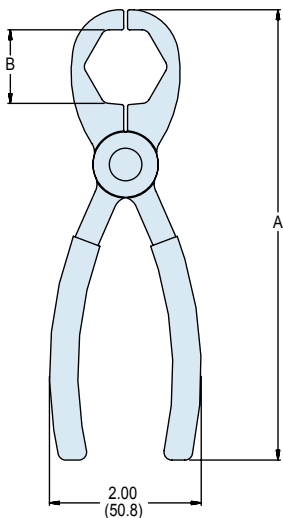
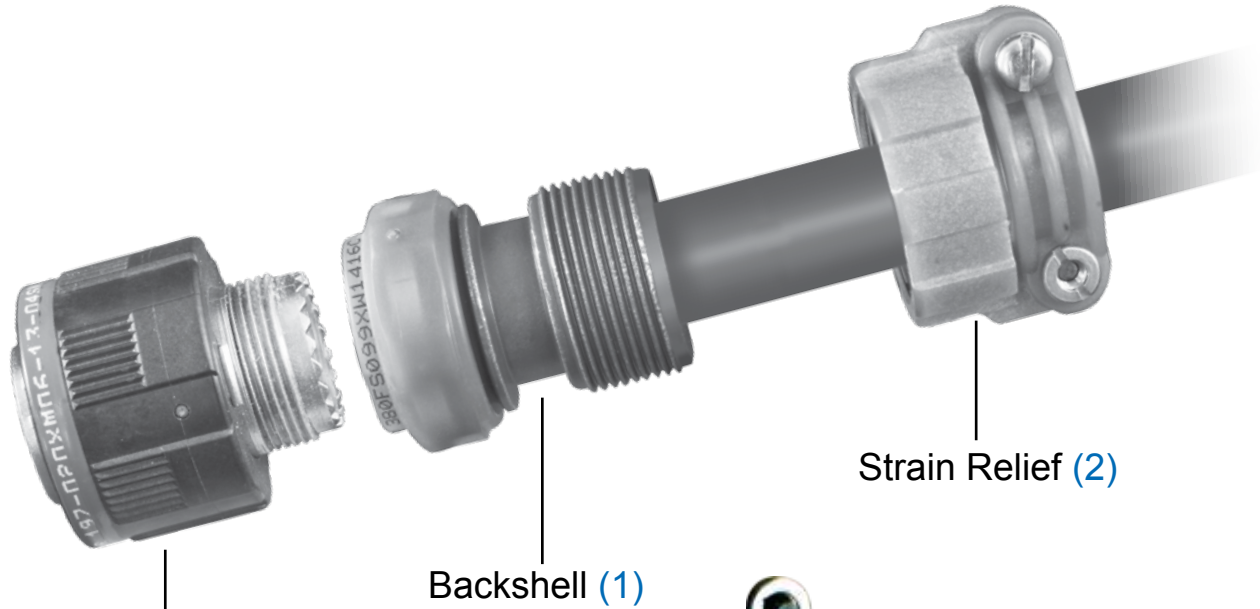
Dash No.	L Dia ±.015 (0.4)
50	.425 (10.8)
52	.485 (12.3)
54	.640 (16.3)
56	.750 (19.1)
58	.890 (22.6)
60	1.015 (25.8)
62	1.095 (27.8)
64	1.130 (28.7)
66	1.250 (31.8)
68	1.350 (34.3)
70	1.390 (35.3)
72	1.485 (37.7)
74	1.625 (41.3)
76	1.750 (44.5)
78	1.875 (47.6)
80	1.980 (50.3)
82	2.060 (52.3)
84	2.235 (56.8)
86	2.310 (58.7)
88	2.475 (62.9)
90	2.655 (67.4)
92	2.810 (71.4)
94	3.045 (77.3)

Dash No.	M Dia ±.015 (0.4)
08	.468 (11.9)
10	.593 (15.1)
12	.718 (18.2)
13	.765 (19.4)
14	.844 (21.4)
15	.890 (22.6)
16	.968 (24.6)
17	1.015 (25.8)
18	1.093 (27.8)
19	1.140 (29.0)
20	1.203 (30.6)
21	1.265 (32.1)
22	1.343 (34.1)
23	1.453 (36.9)
24	1.484 (37.7)
25	1.577 (40.1)
27	1.640 (41.7)
28	1.687 (42.8)
29	1.765 (44.8)
30	1.890 (48.0)
31	1.953 (49.6)
32	1.968 (50.0)
33	2.077 (52.8)
35	2.140 (54.4)
36	2.187 (55.5)
40	2.406 (61.1)
44	2.656 (67.5)
48	3.031 (77.0)

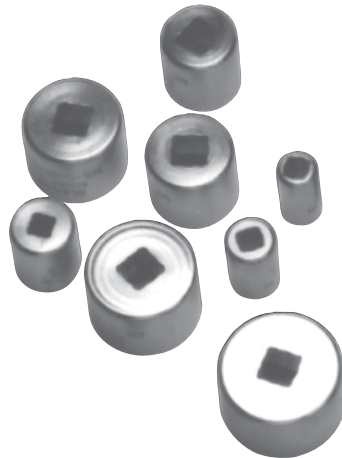
Dash No.	N Dia ±.015 (0.4)
100	.391 (9.9)
101	.516 (13.1)
102	.583 (14.8)
103	.641 (16.3)
104	.708 (18.0)
105	.766 (19.5)
205	.788 (20.0)
106	.896 (22.2)
206	.907 (23.0)
107	1.016 (25.8)
207	1.025 (26.0)
108	1.141 (29.0)
208	1.203 (30.6)
109	1.266 (32.2)
110	1.391 (35.3)
111	1.521 (38.6)
211	1.536 (39.0)
112	1.641 (41.7)
113	1.766 (44.9)
114	1.891 (48.0)
115	2.078 (52.8)
116	2.406 (61.1)
117	2.510 (63.8)

A

Series 360 Non-Environmental Backshell Assembly Instructions



(3) 600-157  
Stainless Steel Composite  
Hex Coupling Wrench



(4) Plug and Receptacle  
Holding Tools  
for 1/4" and 3/8" Socket



(5) 600-161  
Hand Held Digital  
Torque Wrench

COMPOSITE COUPLING TORQUE VALUES	
Shell Size Reference	Composite Torque (Inch-Pounds)
08/09	35
10/11	35
12/13	40
14/15	40
16/17	40
18/19	40
20/21	80
22/23	80
24/25	80
28	120
32	120
36	120

## Series 360 Non-Environmental Backshell Assembly Instructions



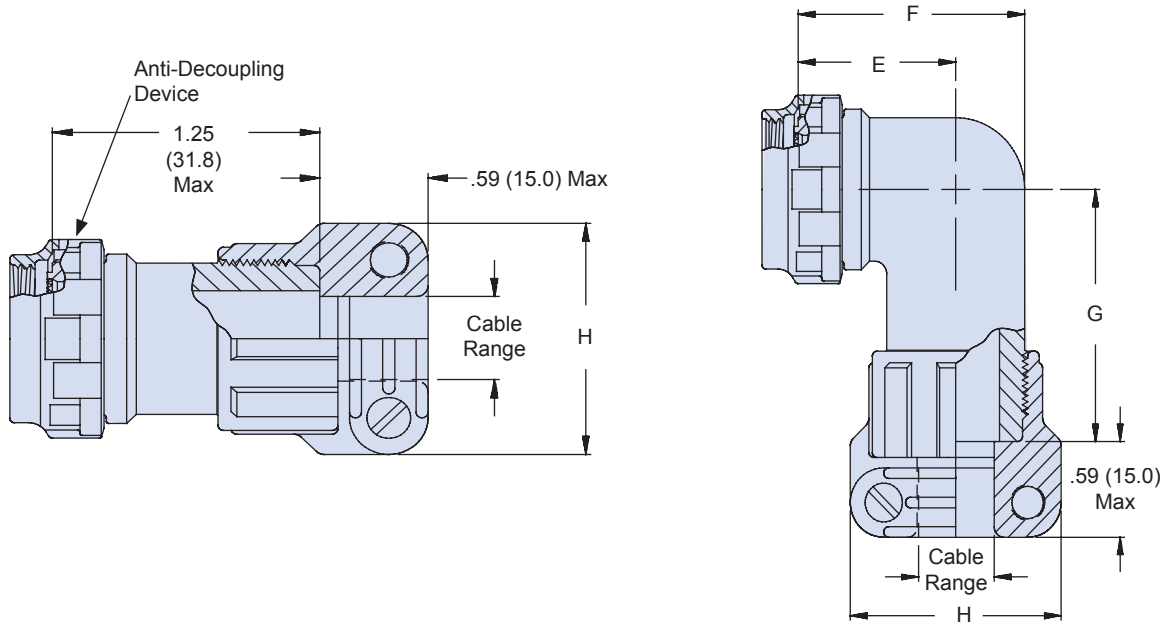
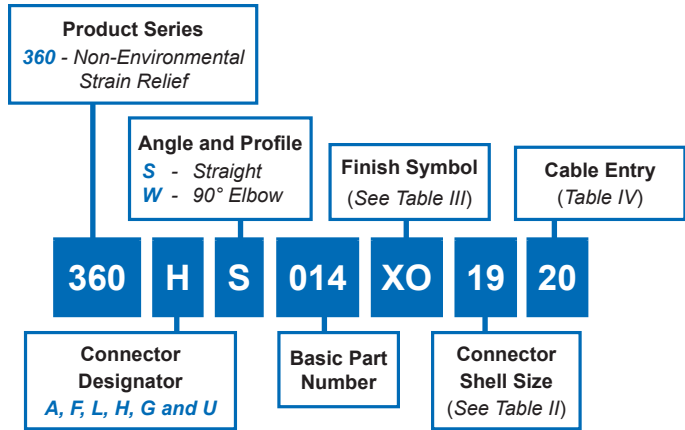
The following suggested procedure serves as a guide for proper assembly and installation of Glenair Series 360 Non-Environmental Composite Backshells. It is recommended that trial samples of appropriate cables or wire bundles be used to determine proper trim dimensions of the individual conductors and cable jackets, if applicable.

**NOTE: As with any electrical connector assembly procedure, be sure to use the proper tools. For convenient, reliable assembly of the connectors and backshells, it is suggested that Glenair's connector holding tools, strap wrenches and connector pliers be used.**

1. Temporarily assemble backshell (1) to connector.
2. If cable is jacketed, insert cable into backshell (1) and bottom against connector. Hold cable in position and mark cable jacket at rear end of backshell.
3. Remove backshell from connector and stage the backshell, together with the strain relief clamp (2), up the cable for installation after wires are terminated to the connector contacts.
4. Trim cable jacket at a point 1/2 inch toward connector from mark made in step two above.
5. Prepare and terminate cable conductors in accordance with established practices.
6. Thread backshell (1) onto the connector and tighten securely. Glenair recommends the use of the appropriate sized series 600-157 composite hex coupling wrench (3) to prevent damage to the composite backshell coupling nut. For added convenience in assembly, an appropriately sized series 600-005 connector holding tool (4) is recommended, as well as Glenair digital torque wrench (5).
7. Assemble strain relief (2) to backshell and tighten securely. Tighten strain relief saddles securely on cable or harness (see saddle clamp assembly procedure).

A

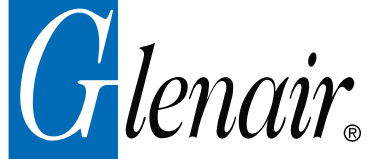
CONNECTOR DESIGNATOR:	
<b>A</b>	MIL-DTL-5015, -26482 Series II, and -83723 Series I and III
<b>F</b>	MIL-DTL-38999 Series I, II
<b>L</b>	MIL-DTL-38999 Series 1.5 (JN1003)
<b>H</b>	MIL-DTL-38999 Series III and IV
<b>G</b>	MIL-DTL-28840
<b>U</b>	DG123 and DG123A
<b>SELF-LOCKING</b>	
<b>ROTATABLE COUPLING</b>	
<b>STANDARD PROFILE</b>	



### NOTES

1. Coupling nut supplied unplated.
2. See Table I in Intro for front-end dimensional details.

**360-014**  
**Composite Non-Environmental Backshell**  
**with Self-Locking Rotatable Coupling**  
**and Strain Relief**



**TABLE II: CONNECTOR SHELL SIZE ORDER NUMBER**

Shell Size For Connector Designator*					E	F	G	Max Entry
A	F/L	H	G	U	±.06 (1.5)	±.09 (2.3)	±.09 (2.3)	Dash No.**
08	08	09	-	-	.69 (17.5)	.88 (22.4)	1.06 (27.0)	10
10	10	11	-	08	.75 (19.1)	1.00 (25.4)	1.13 (28.7)	12
12	12	13	11	10	.81 (20.6)	1.13 (28.7)	1.19 (30.2)	14
14	14	15	13	12	.88 (22.4)	1.31 (33.3)	1.38 (35.1)	16
16	16	17	15	14	.94 (23.9)	1.38 (35.1)	1.44 (36.6)	20
18	18	19	17	16	.97 (24.6)	1.44 (36.6)	1.47 (37.3)	20
20	20	21	19	18	1.06 (26.9)	1.63 (41.4)	1.56 (39.6)	22
22	22	23	-	20	1.13 (28.7)	1.75 (44.5)	1.63 (41.4)	24
24	24	25	23	22	1.19 (30.2)	1.88 (47.8)	1.69 (42.9)	28
28	-	-	25	24	1.34 (34.0)	2.13 (54.1)	1.78 (45.2)	32

\*\*Consult factory for additional entry sizes available.

**TABLE III: FINISH**

Symbol	Finish Description
XB	No Plating - Black Color
XM	2000 Hour Corrosion Resistant Electroless Nickel
XMT	2000 Hour Corrosion Resistant Ni-PTFE, Nickel-Fluorocarbon Polymer. <i>1000 Hour Grey™</i>
XO	No Plating - Brown Color
XW	2000 Hour Corrosion Resistant Cadmium/Olive Drab over Electroless Nickel

**TABLE IV: CABLE ENTRY**

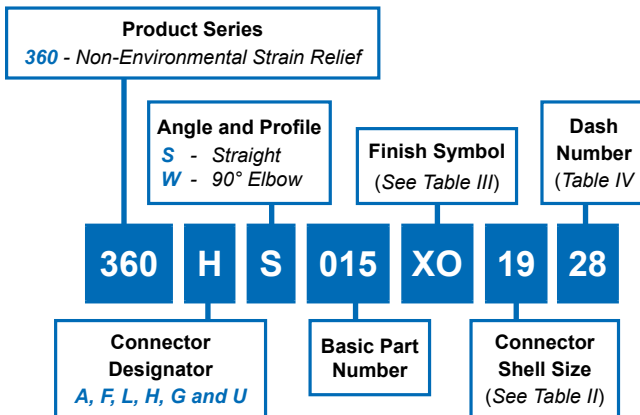
Dash No.	H		Cable Range	
	±.06 (1.5)	Minimum	Maximum	
10	.94 (23.9)	.16 (4.0)	.25 (6.4)	
12	1.17 (29.7)	.29 (5.1)	.38 (9.7)	
14	1.28 (32.5)	.40 (10.1)	.44 (11.2)	
16	1.41 (35.8)	.52 (12.7)	.63 (15.9)	
18	1.50 (38.1)	.58 (14.7)	.69 (17.5)	
20	1.56 (39.6)	.64 (16.3)	.75 (19.1)	
22	1.69 (42.9)	.72 (18.3)	.88 (22.2)	
24	1.81 (46.0)	.79 (20.0)	1.00 (25.4)	
28	1.91 (48.5)	.89 (20.3)	1.13 (28.6)	
32	2.02 (51.3)	.96 (24.4)	1.25 (31.8)	



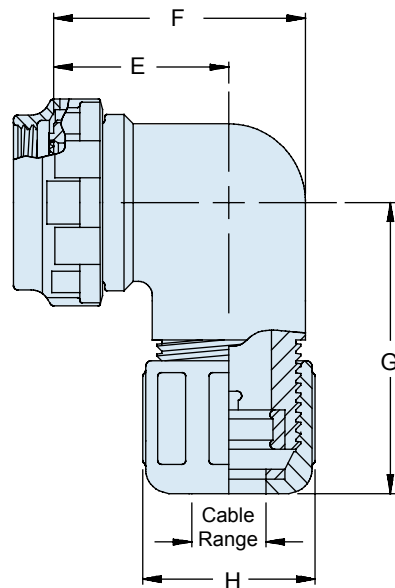
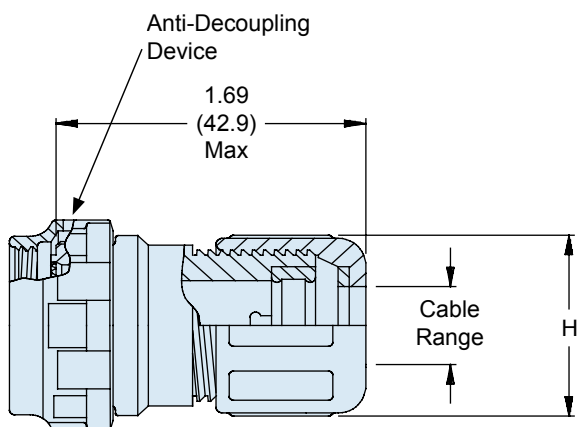
# 360-015 Composite Non-Environmental Backshell with Self-Locking Rotatable Coupling and Qwik-Clamp Strain-Relief

A

CONNECTOR DESIGNATOR:	
<b>A</b>	MIL-DTL-5015, -26482 Series II, and -83723 Series I and III
<b>F</b>	MIL-DTL-38999 Series I, II
<b>L</b>	MIL-DTL-38999 Series 1.5 (JN1003)
<b>H</b>	MIL-DTL-38999 Series III and IV
<b>G</b>	MIL-DTL-28840
<b>U</b>	DG123 and DG123A
<b>SELF-LOCKING</b>	
<b>ROTATABLE COUPLING</b>	
<b>STANDARD PROFILE</b>	



US PATENT 5211576



## NOTES

1. Coupling nut supplied unplated.
2. See Table I in Intro for front-end dimensional details.
3. Metric dimensions (mm) are in parentheses and are for reference only

**360-015**  
**Composite Non-Environmental Backshell**  
 with Self-Locking Rotatable Coupling  
 and Qwik-Clamp Strain-Relief



**TABLE II: CONNECTOR SHELL SIZE ORDER NUMBER**

Shell Size For		E		F		G		Max Entry Dash No. *
Connector Designator	G & U	± .06	(1.5)	± .09	(2.3)	± .09	(2.3)	
A, F/L, & H	G & U							
08, 09	---	.69	(17.5)	.88	(22.4)	1.19	(30.2)	08
03, 10, 11	08	.75	(19.1)	1.00	(25.4)	1.25	(31.8)	12
12, 13	10, 11	.81	(20.6)	1.13	(28.7)	1.31	(33.3)	16
14, 15	12, 13	.88	(22.4)	1.31	(33.3)	1.38	(35.1)	20
16, 17	14, 15	.94	(23.9)	1.38	(35.1)	1.44	(36.6)	24
18, 19	16, 17	.97	(24.6)	1.44	(36.6)	1.47	(37.3)	28
20, 21	18, 19	1.06	(26.9)	1.63	(41.4)	1.56	(39.6)	32
22, 23	20	1.13	(28.7)	1.75	(44.5)	1.63	(41.4)	36
24, 25, 61	22, 23	1.19	(30.2)	1.88	(47.8)	1.69	(42.9)	40
28	24, 25	1.34	(34.0)	2.13	(54.1)	1.78	(45.2)	44

\* Consult factory for additional entry sizes available.

**TABLE III: FINISH**

Symbol	Finish Description
XB	No Plating - Black Color
XM	2000 Hour Corrosion Resistant Electroless Nickel
XMT	2000 Hour Corrosion Resistant Ni-PTFE, Nickel-Fluorocarbon Polymer. <i>1000 Hour Grey™</i>
XO	No Plating - Brown Color
XW	2000 Hour Corrosion Resistant Cadmium/Olive Drab over Electroless Nickel

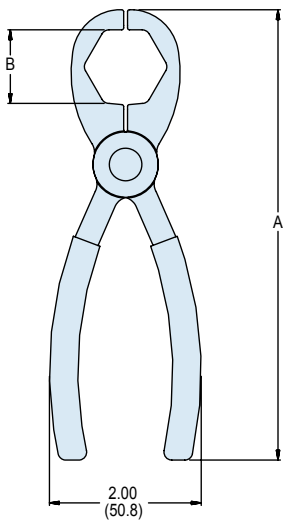
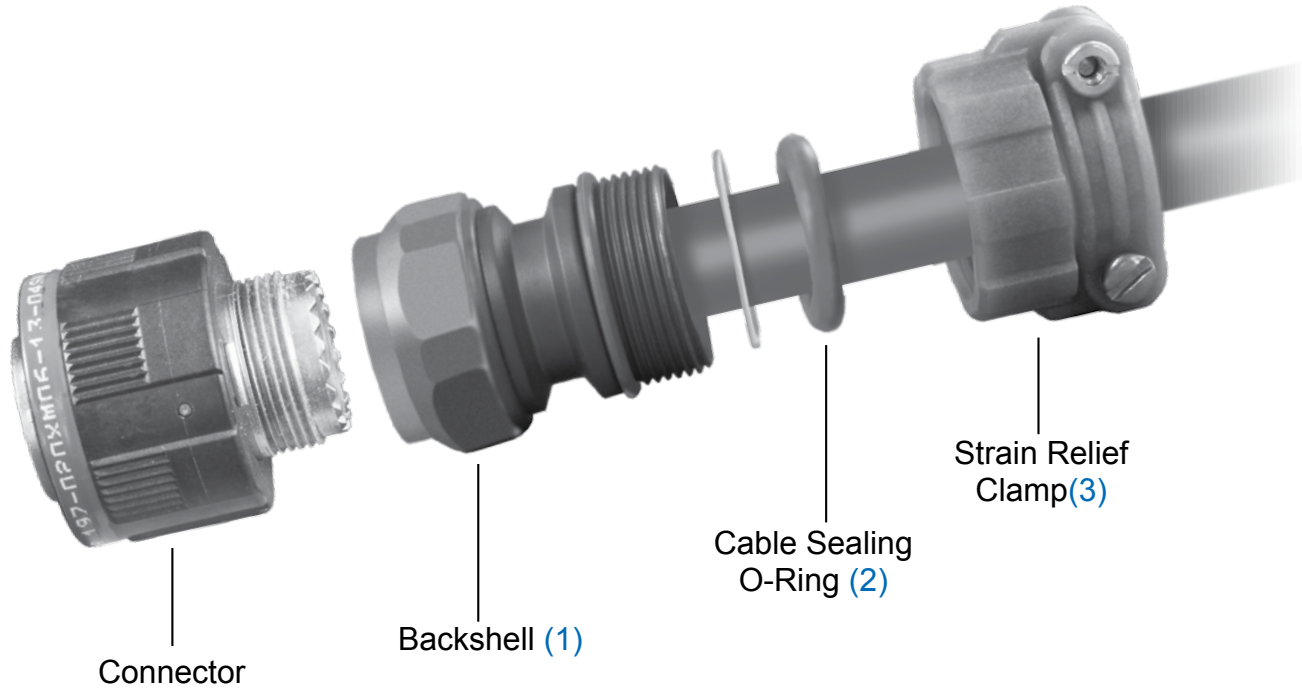
**TABLE IV: CABLE ENTRY**

Dash No	H (Max)		Saddle Kit *		Cable Range			
	±.06	(1.5)	Minimum	Minimum	Minimum	Maximum	Maximum	Maximum
08	.72	(18.3)	---	---	.10	(2.5)	.25	(6.4)
12	.91	(23.1)	.10	(2.5)	.20	(5.1)	.38	(9.7)
16	1.09	(27.7)	.10	(2.5)	.33	(8.4)	.50	(12.7)
20	1.22	(31.0)	.20	(5.1)	.45	(11.4)	.63	(15.9)
24	1.34	(34.0)	.33	(8.4)	.52	(13.2)	.75	(19.1)
28	1.53	(38.9)	.45	(11.4)	.64	(16.3)	.88	(22.2)
32	1.72	(43.7)	.52	(13.2)	.77	(19.6)	1.00	(25.4)
36	1.85	(47.0)	.64	(16.3)	.86	(21.8)	1.13	(28.6)
40	1.97	(50.0)	.77	(19.6)	.98	(24.9)	1.25	(31.8)
44	2.09	(53.1)	.86	(21.8)	1.13	(28.6)	1.38	(34.9)

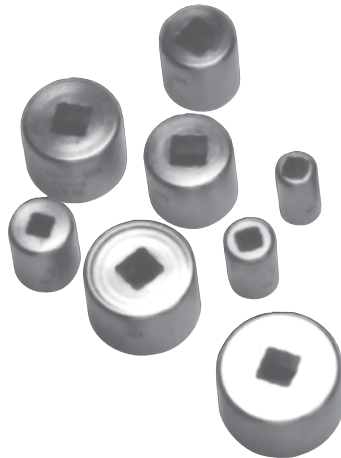
\* Consult factory for availability of special saddle bar kit to reduce minimum clamp range.

A

## Series 370 Environmental Backshell Assembly Instructions



(4) 600-157  
Stainless Steel Composite  
Hex Coupling Wrench



(5) Plug and Receptacle  
Holding Tools  
for 1/4" and 3/8" Socket



(6) 600-161  
Hand Held Digital  
Torque Wrench

COMPOSITE COUPLING TORQUE VALUES	
Shell Size Reference	Composite Torque (Inch-Pounds)
08/09	35
10/11	35
12/13	40
14/15	40
16/17	40
18/19	40
20/21	80
22/23	80
24/25	80
28	120
32	120
36	120



## Series 370 Environmental Backshell Assembly Instructions



The following suggested procedure serves as a guide for proper assembly and installation of straight Glenair Series 370 Cable Sealing Backshells for use with jacketed cables. It is recommended that trial samples of appropriate cables be used to determine proper trim dimensions of the cable jacket and individual conductors.

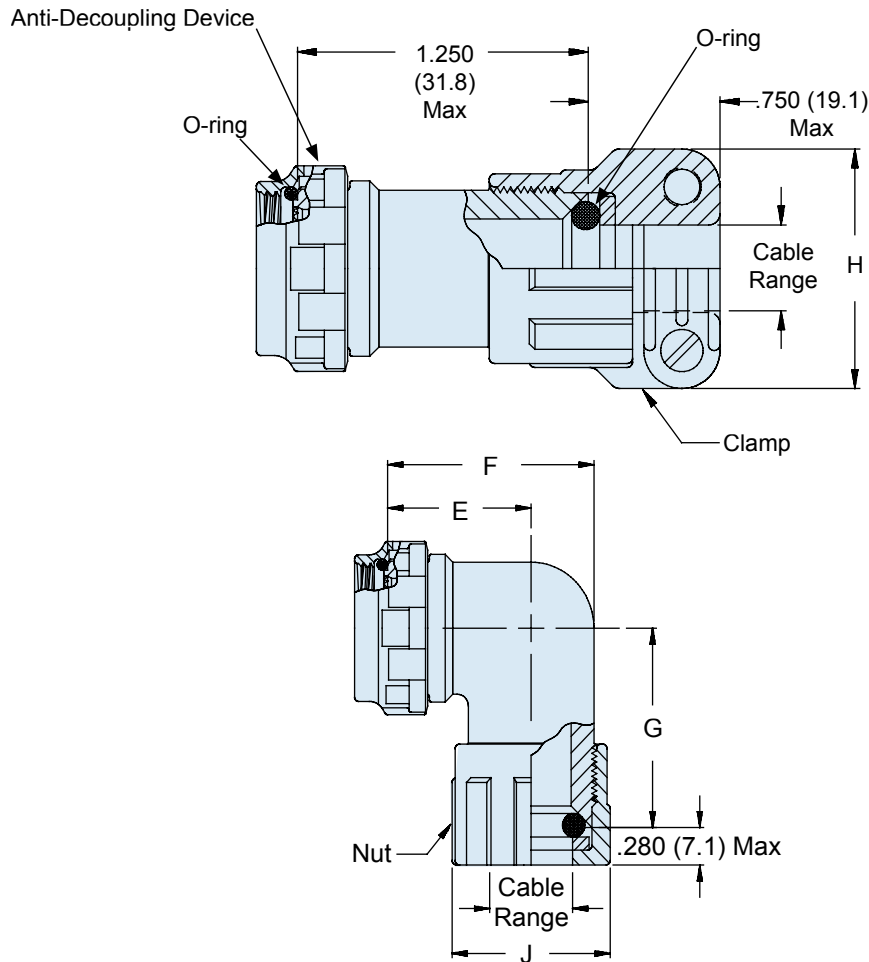
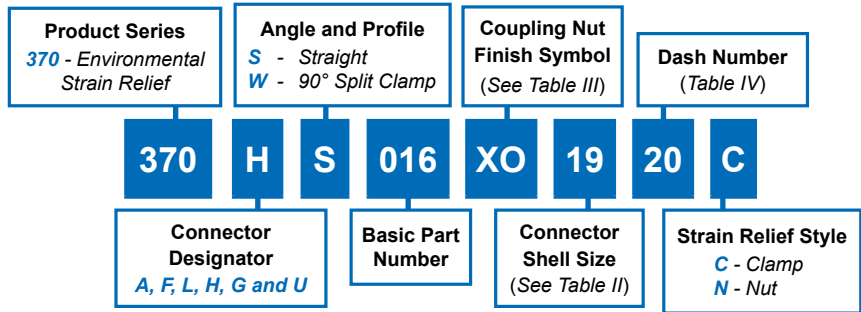
**NOTE: As with any electrical connector assembly procedure, be sure to use the proper tools. For convenient reliable assembly of the connector and backshell, it is suggested that Glenair's connector holding tools, strap wrenches and connector pliers be used.**

1. Temporarily assemble backshell (1) to connector.
2. Remove the strain relief clamp (3) and cable sealing o-ring (2) from the backshell and stage them in the order shown up the cable for installation after wires are terminated to the connector contacts.
3. Insert cable into backshell (1) and bottom against connector. Hold cable in position and mark cable jacket at rear end of backshell.
4. Remove backshell from connector and place on cable with components from step two above.
5. Trim cable jacket at a point 3/4 inch toward connector from mark made in step two above.
6. Prepare and terminate wires in accordance with established practices.
7. Thread backshell (1) onto the connector and tighten securely. Glenair recommends the use of the appropriate sized series 600-157 composite hex coupling wrench (4) to prevent damage to the composite backshell coupling nut. For added convenience in assembly, an appropriately sized series 600-005 connector holding tool (5) is recommended, as well as Glenair digital torque wrench (6).
8. Slide washer (if supplied) and O-ring (2) on to backshell and tighten strain relief clamp (3) firmly in place
9. If provided, tighten saddle bar clamps until they bottom against saddle clamp ears (see saddle clamp assembly procedure).

# 370-016 Composite Cable-Sealing Environmental Backshell with Self-Locking Rotatable Coupling and Strain-Relief Clamp or Nut

A

CONNECTOR DESIGNATOR:	
<b>A</b>	MIL-DTL-5015, -26482 Series II, and -83723 Series I and III
<b>F</b>	MIL-DTL-38999 Series I, II
<b>L</b>	MIL-DTL-38999 Series 1.5 (JN1003)
<b>H</b>	MIL-DTL-38999 Series III and IV
<b>G</b>	MIL-DTL-28840
<b>U</b>	DG123 and DG123A
<b>SELF-LOCKING</b>	
<b>ROTATABLE COUPLING</b>	
<b>STANDARD PROFILE</b>	



# 370-016

## Composite Cable-Sealing Environmental Backshell with Self-Locking Rotatable Coupling and Strain-Relief Clamp or Nut



**TABLE II: CONNECTOR SHELL SIZE ORDER NUMBER**

Shell Size For Connector Designator*					E	F	G	Max Entry
A	F/L	H	G	U	±.06 (1.5)	±.09 (2.3)	±.09 (2.3)	Dash No.**
08	08	09	-	-	.69 (17.5)	.88 (22.4)	1.06 (26.9)	10
10	10	11	-	08	.75 (19.1)	1.00 (25.4)	1.13 (28.7)	12
12	12	13	11	10	.81 (20.6)	1.13 (28.7)	1.19 (30.2)	14
14	14	15	13	12	.88 (22.4)	1.31 (33.3)	1.25 (31.8)	16
16	16	17	15	14	.94 (23.9)	1.38 (35.1)	1.31 (33.3)	20
18	18	19	17	16	.97 (24.6)	1.44 (36.6)	1.34 (34.0)	20
20	20	21	19	18	1.06 (26.9)	1.63 (41.4)	1.44 (36.6)	22
22	22	23	-	20	1.13 (28.7)	1.75 (44.5)	1.50 (38.1)	24
24	24	25	23	22	1.19 (30.2)	1.88 (47.8)	1.56 (39.6)	28
28	-	-	25	24	1.34 (34.0)	2.13 (54.1)	1.66 (42.2)	32

\*\*Consult factory for additional entry sizes available.

**TABLE IV: CABLE ENTRY**

Dash No.	Clamp Saddle Closed	H		J		Cable Range *			
		±.06 (1.5)	±.06 (1.5)	±.06 (1.5)	±.06 (1.5)	Minimum	Maximum	Minimum	Maximum
10	.20 (5.1)	.94 (23.9)	.80 (20.3)	.13 (3.3)	.25 (6.4)	.13 (3.3)	.25 (6.4)	.13 (3.3)	.25 (6.4)
12	.29 (5.1)	1.17 (29.7)	.93 (23.6)	.25 (6.4)	.38 (9.7)	.25 (6.4)	.38 (9.7)	.25 (6.4)	.38 (9.7)
14	.40 (10.2)	1.28 (32.5)	1.06 (26.9)	.31 (7.9)	.44 (11.2)	.31 (7.9)	.44 (11.2)	.31 (7.9)	.44 (11.2)
16	.48 (12.2)	1.41 (35.8)	1.22 (31.0)	.50 (12.7)	.63 (15.9)	.50 (12.7)	.63 (15.9)	.50 (12.7)	.63 (15.9)
18	.55 (14.0)	1.50 (38.1)	1.24 (31.5)	.56 (14.2)	.69 (17.5)	.56 (14.2)	.69 (17.5)	.56 (14.2)	.69 (17.5)
20	.64 (16.0)	1.56 (39.6)	1.37 (34.8)	.63 (16.0)	.75 (19.1)	.63 (16.0)	.75 (19.1)	.63 (16.0)	.75 (19.1)
22	.72 (18.3)	1.69 (42.9)	1.49 (37.8)	.75 (19.1)	.88 (22.2)	.75 (19.1)	.88 (22.2)	.75 (19.1)	.88 (22.2)
24	.79 (20.1)	1.81 (46.0)	1.62 (41.1)	.88 (22.4)	1.00 (25.4)	.88 (22.4)	1.00 (25.4)	.88 (22.4)	1.00 (25.4)
28	.89 (22.0)	1.91 (48.5)	1.68 (42.7)	1.00 (25.4)	1.13 (28.6)	1.00 (25.4)	1.13 (28.6)	1.00 (25.4)	1.13 (28.6)
32	.96 (24.0)	2.02 (51.3)	1.82 (46.2)	1.13 (28.6)	1.25 (31.8)	1.13 (28.6)	1.25 (31.8)	1.13 (28.6)	1.25 (31.8)

\* Cable range equals diameter of cable outer jacket.

**NOTES**

1. Coupling nut supplied unplated.
2. See Table I in Intro for front-end dimensional details.

**TABLE III: FINISH**

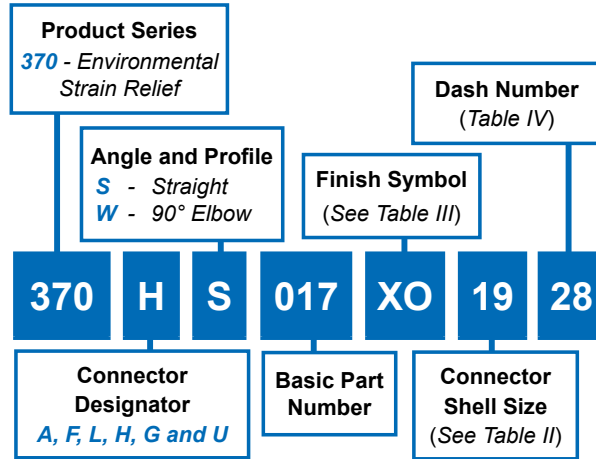
Symbol	Finish Description
XB	No Plating - Black Color (Non-Conductive Finish)
XM	2000 Hour Corrosion Resistant Electroless Nickel
XMT	2000 Hour Corrosion Resistant Ni-PTFE, Nickel-Fluorocarbon Polymer. <i>1000 Hour Grey™</i>
XO	No Plating - Brown Color (Non-Conductive Finish)
XW	2000 Hour Corrosion Resistant Cadmium/Olive Drab over Electroless Nickel



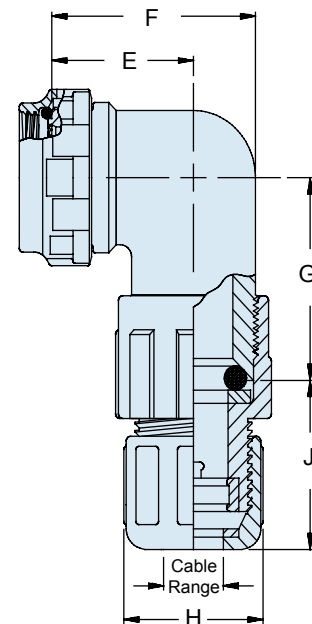
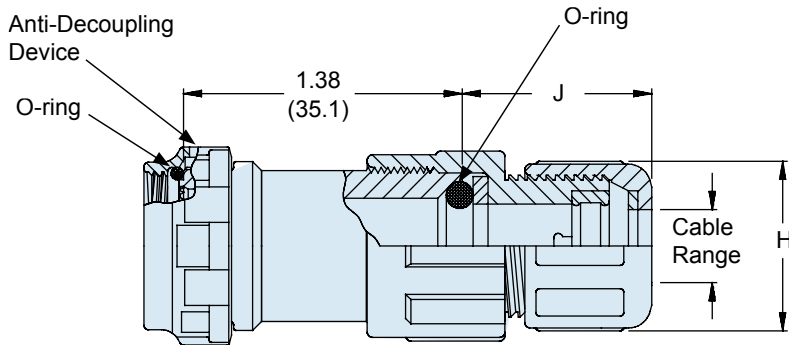
# 370-017 Composite Cable-Sealing Environmental Backshell with Self-Locking Rotatable Coupling and Qwik-Clamp

A

CONNECTOR DESIGNATOR:	
<b>A</b>	MIL-DTL-5015, -26482 Series II, and -83723 Series I and III
<b>F</b>	MIL-DTL-38999 Series I, II
<b>L</b>	MIL-DTL-38999 Series 1.5 (JN1003)
<b>H</b>	MIL-DTL-38999 Series III and IV
<b>G</b>	MIL-DTL-28840
<b>U</b>	DG123 and DG123A
<b>SELF-LOCKING</b>	
<b>ROTATABLE COUPLING</b>	
<b>STANDARD PROFILE</b>	



US PATENT 5211576



### NOTES

1. Coupling nut supplied unplated.
2. See Table I in Intro for front-end dimensional details.

# 370-017

## Composite Cable-Sealing Environmental Backshell with Self-Locking Rotatable Coupling and Qwik-Clamp



Composite Backshells

A

**TABLE II: CONNECTOR SHELL SIZE ORDER NUMBER**

Shell Size For Connector Designator*					E		F		G		Max Entry Dash No.**
A	F/L	H	G	U	± .06	(1.5)	± .09	(2.3)	± .09	(2.3)	
08	08	09	-	-	.69	(17.5)	.88	(22.4)	1.06	(26.9)	08
10	10	11	-	08	.75	(19.1)	1.00	(25.4)	1.13	(28.7)	12
12	12	13	11	10	.81	(20.6)	1.13	(28.7)	1.19	(30.2)	16
14	14	15	13	12	.88	(22.4)	1.31	(33.3)	1.25	(31.8)	20
16	16	17	15	14	.94	(23.9)	1.38	(35.1)	1.31	(33.3)	24
18	18	19	17	16	.97	(24.6)	1.44	(36.6)	1.34	(34.0)	28
20	20	21	19	18	1.06	(26.9)	1.63	(41.4)	1.44	(36.6)	32
22	22	23	-	20	1.13	(28.7)	1.75	(44.5)	1.50	(38.1)	36
24	24	25	23	22	1.19	(30.2)	1.88	(47.8)	1.56	(39.6)	40
28	-	-	25	24	1.34	(34.0)	2.13	(54.1)	1.66	(42.2)	44

\*\*Consult factory for additional entry sizes available.

**TABLE III: FINISH**

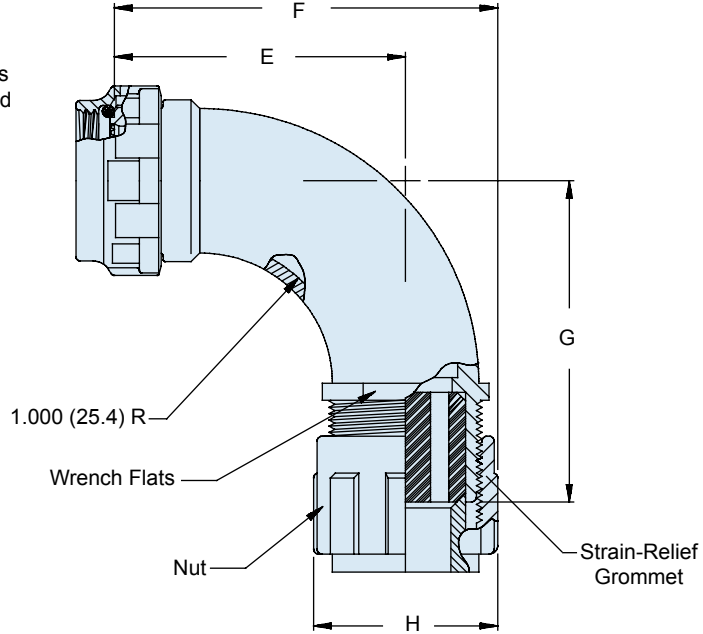
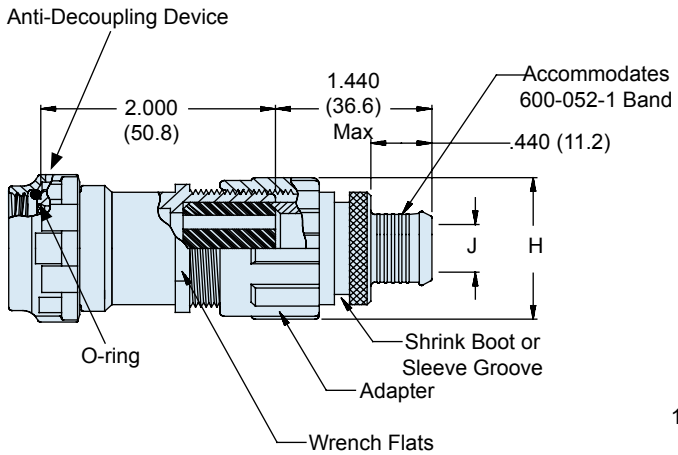
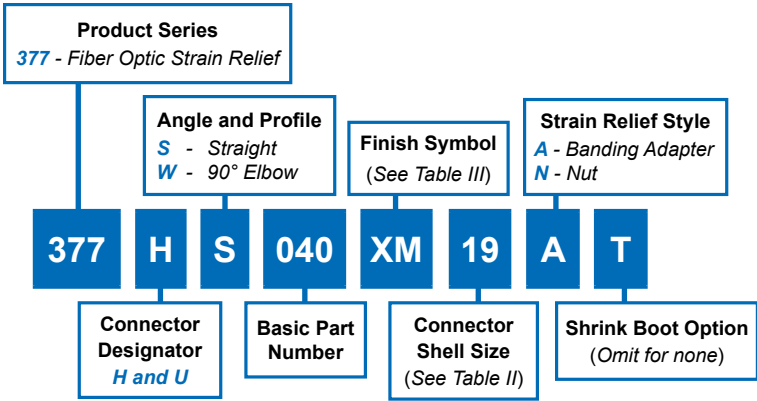
Symbol	Finish Description
XB	No Plating - Black Color (Non-Conductive Finish)
XM	2000 Hour Corrosion Resistant Electroless Nickel
XMT	2000 Hour Corrosion Resistant Ni-PTFE, Nickel-Fluorocarbon Polymer. 1000 Hour Grey™
XO	No Plating - Brown Color (Non-Conductive Finish)
XW	2000 Hour Corrosion Resistant Cadmium/Olive Drab over Electroless Nickel

**TABLE IV: CABLE ENTRY**

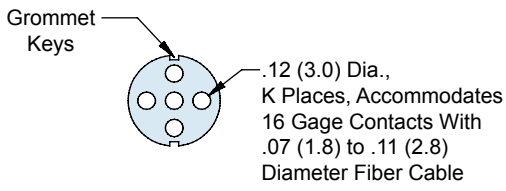
Dash No.	H	J	Cable Range	
	(Max)	(Max)	Minimum	Maximum
08	.72 (18.3)	.87 (22.1)	.13 (3.3)	.25 (6.4)
12	.91 (23.1)	1.01 (25.7)	.22 (5.6)	.38 (9.7)
16	1.09 (27.7)	1.11 (28.2)	.34 (8.6)	.50 (12.7)
20	1.22 (31.0)	1.11 (28.2)	.47 (11.9)	.63 (15.9)
24	1.34 (34.0)	1.11 (28.2)	.60 (15.0)	.75 (19.1)
28	1.53 (38.9)	1.26 (32.0)	.72 (18.3)	.88 (22.2)
32	1.72 (43.7)	1.41 (35.8)	.84 (21.3)	1.00 (25.4)
36	1.85 (47.0)	1.41 (35.8)	.97 (24.6)	1.13 (28.6)
40	1.97 (50.0)	1.41 (35.8)	1.09 (27.7)	1.25 (31.8)
44	2.09 (53.1)	1.53 (38.9)	1.22 (31.0)	1.38 (34.9)

A

CONNECTOR DESIGNATOR:	
<b>H</b>	MIL-DTL-38999 Series III and IV
<b>U</b>	DG123 and DG123A
<b>SELF-LOCKING</b>	
<b>ROTATABLE COUPLING</b>	
<b>STANDARD PROFILE</b>	



U.S. PATENT NO. 6358077



**377-040**  
**Composite Fiber-Optic Strain-Relief Backshell**  
**with Cable Alignment Grommet**  
**and Self-Locking Rotatable Coupling**



**TABLE II: CONNECTOR SHELL SIZE ORDER NUMBER**

Shell Size For Conn. Desig.		E		F		G		H		J		K (# of Holes)*	
H	U	±.06	(1.5)	±.09	(2.3)	±.06	(1.5)	(Max)	Ref.			Code H	Code U
11	---	1.70	(43.2)	2.39	(60.7)	1.90	(48.3)	1.41 (35.8)	.27 (6.9)			2	---
13	11	1.78	(45.2)	2.47	(62.7)	1.96	(49.8)	1.41 (35.8)	.33 (8.4)			4	2
15	13	1.82	(46.2)	2.51	(63.8)	2.02	(51.3)	1.41 (35.8)	.39 (9.9)			5	4
17	15	1.89	(48.0)	2.70	(68.6)	2.09	(53.1)	1.64 (41.7)	.51 (13.0)			8	5
19	17	1.93	(49.0)	2.74	(69.6)	2.13	(54.1)	1.64 (41.7)	.64 (16.3)			11	8
21	19	2.00	(50.8)	2.94	(74.7)	2.19	(55.6)	1.89 (48.0)	.77 (19.6)			16	11
23	21	2.08	(52.8)	3.02	(76.7)	2.25	(57.2)	1.89 (48.0)	.84 (21.3)			21	16
25	23	2.14	(54.4)	3.20	(81.3)	2.32	(58.9)	2.16 (54.9)	.84 (21.3)			29	21
---	25	2.22	(56.4)	3.28	(83.3)	2.39	(60.7)	2.16 (54.9)	.89 (22.6)			---	29

\* Use Glenair 687-142 seal plug in vacant holes

**TABLE III: FINISH**

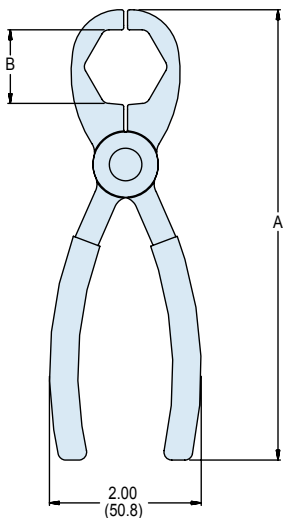
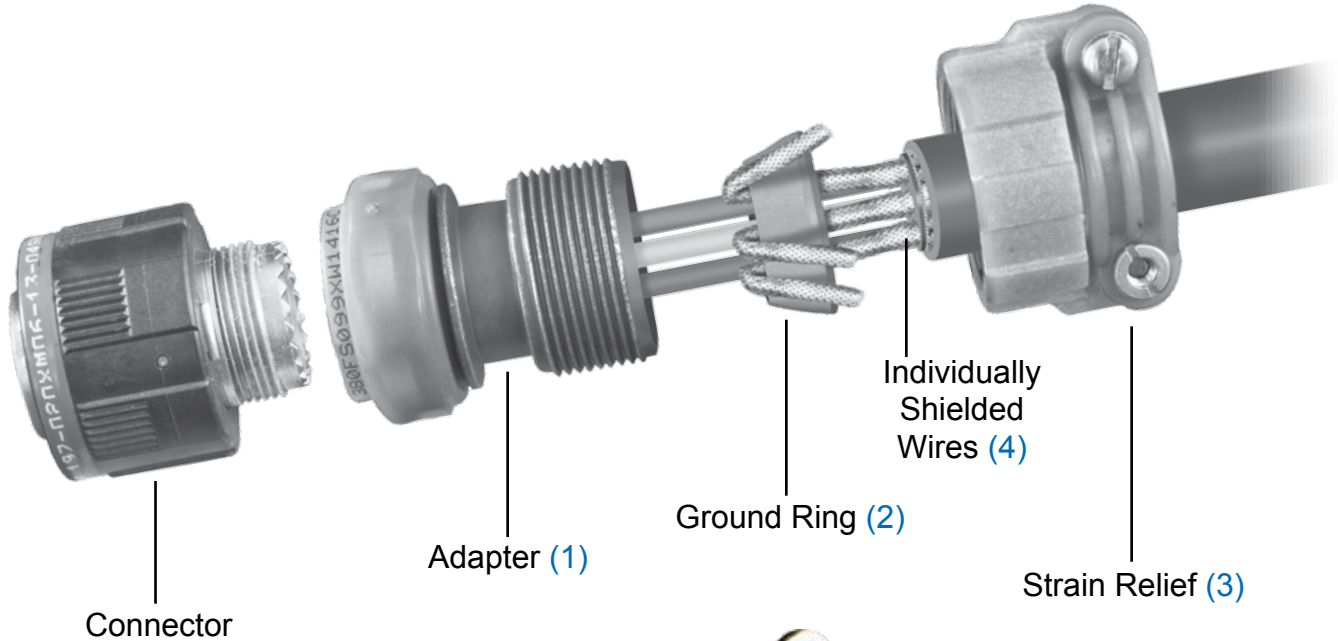
Symbol	Finish Description
XB	No Plating - Black Color (Non-Conductive Finish)
XO	No Plating - Brown Color (Non-Conductive Finish)

**NOTES**

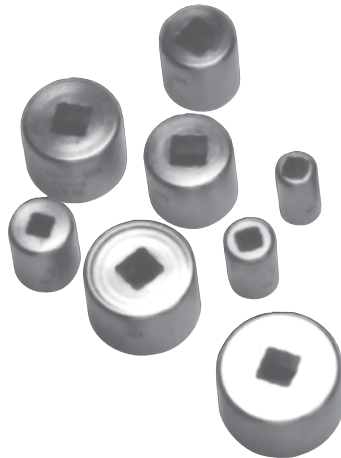
1. See Table I in Intro for front-end dimensional details.
2. Metric dimensions (mm) are in parentheses and are for reference only

Series 380 EMI/RFI Non-Environmental (Type D) Assembly Instructions

A



(5) 600-157 Stainless Steel Composite Hex Coupling Wrench



(6) Plug and Receptacle Holding Tools for 1/4" and 3/8" Socket



(7) 600-161 Hand Held Digital Torque Wrench

COMPOSITE COUPLING TORQUE VALUES	
Shell Size Reference	Composite Torque (Inch-Pounds)
08/09	35
10/11	35
12/13	40
14/15	40
16/17	40
18/19	40
20/21	80
22/23	80
24/25	80
28	120
32	120
36	120



The following suggested procedure serves as a guide for the proper assembly and installation of Glenair Series 380 EMI/RFI Non-Environmental Backshells (Type D individual wire shield termination). It is recommended that trial samples of appropriate cables or harnesses be used to determine proper trim dimensions of the outer shield and individual conductors.

**NOTE: As with any electrical connector assembly procedure, be sure to use the proper tools. For convenient, reliable assembly of the connector and backshell, it is suggested that Glenair's connector holding tools, strap wrenches and connector pliers be used.**

1. Temporarily assemble backshell (1) to connector.
2. Remove strain relief clamp (3) from adapter (1) and stage it, along with the ground ring (2) in the sequence pictured, up the cable for installation after wires are terminated to the connector contacts.
3. Insert cable into adapter (1), and bottom against connector. Hold cable in position and mark outer shield at rear end of adapter (1).
4. Remove adapter (1) from connector and place on cable with items in step two above.
5. Trim cable jacket at a point 3/4 inch toward connector from mark made in step three above, exposing individual conductors.
6. Trim outer shield at mark made in step three above (this procedure is for termination of individually shielded conductors only).
7. Extract shield pigtail from individual conductors. Fold back and tape or tie pigtails flat against the wire bundle.
8. Prepare and terminate contacts to individual conductors in accordance with established practices. (Crimp or solder in place)
9. Slide adapter (1) forward to connector, and tighten securely using appropriate tools.
10. Move the tapered ground ring forward near the rear of the adapter. Untie individual pigtails, and flare back over ground ring as to evenly disperse pigtails around the circumference of the ring. Tie or tape pigtails back to bundle allowing for approx. 1/2 inch of slack.
11. Push ground ring forward and into the tapered counter-bore at the rear of the backshell adapter (1).
12. Thread strain relief clamp (3) onto the adapter (1) and tighten securely.
13. Tighten strain relief saddle bar clamps until they bottom against saddle ears (see saddle clamp assembly procedure). This will provide good shielding and bonding to the adapter shell. (This same procedure can also be utilized for overall shield).



# 380-099 Composite Cone and Ring Style EMI/RFI Shield Termination Backshell with Self-Locking Coupling Nut and Strain Relief

A

CONNECTOR DESIGNATOR:	
<b>A</b>	MIL-DTL-5015, -26482 Series II, and -83723 Series I and III
<b>F</b>	MIL-DTL-38999 Series I, II
<b>L</b>	MIL-DTL-38999 Series 1.5 (JN1003)
<b>H</b>	MIL-DTL-38999 Series III and IV
<b>G</b>	MIL-DTL-28840
<b>U</b>	DG123 and DG123A
<b>SELF-LOCKING</b>	
<b>ROTATABLE COUPLING</b>	
<b>STANDARD PROFILE</b>	

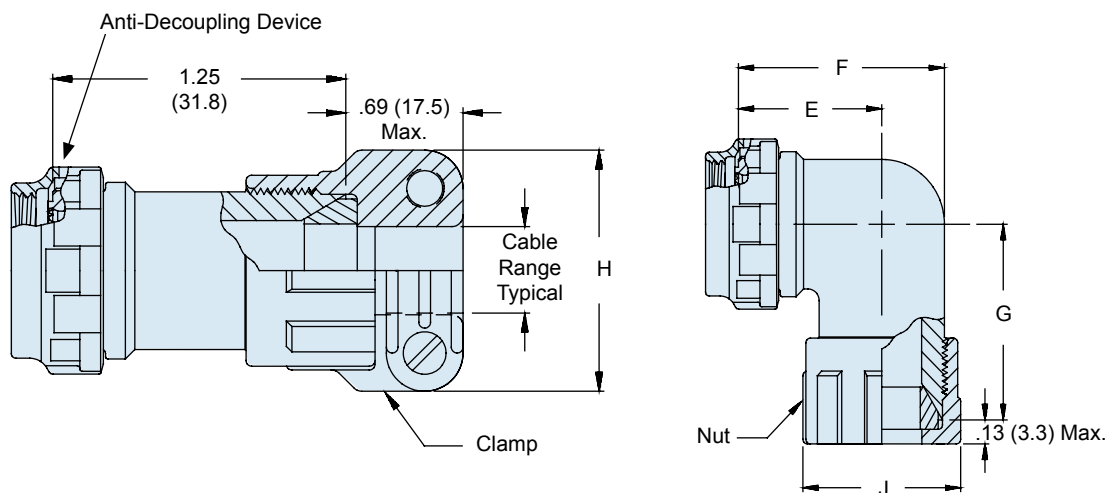
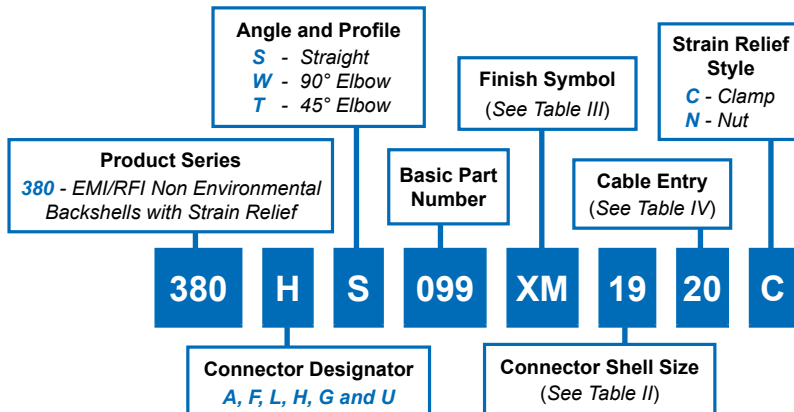


TABLE II: CONNECTOR SHELL SIZE

Shell Size For Connector Designator		E	F	G	Max Entry
A	F/L H G U	±.06 (1.5)	±.09 (2.3)	±.09 (2.3)	Dash No.**
08	08 09 - -	.69 (17.5)	.88 (22.4)	1.19 (30.2)	10
10	10 11 - 08	.75 (19.1)	1.00 (25.4)	1.25 (31.8)	12
12	12 13 11 10	.81 (20.6)	1.13 (28.7)	1.31 (33.3)	14
14	14 15 13 12	.88 (22.4)	1.31 (33.3)	1.38 (35.1)	16
16	16 17 15 14	.94 (23.9)	1.38 (35.1)	1.44 (36.6)	20
18	18 19 17 16	.97 (24.6)	1.44 (36.6)	1.47 (37.3)	20
20	20 21 19 18	1.06 (26.9)	1.63 (41.4)	1.56 (39.6)	22
22	22 23 - 20	1.13 (28.7)	1.75 (44.5)	1.63 (41.4)	24
24	24 25 23 22	1.19 (30.2)	1.88 (47.8)	1.69 (42.9)	28
28	- - 25 24	1.34 (34.0)	2.13 (54.1)	1.78 (45.2)	32

\*\*Consult factory for additional entry sizes available.  
See Introduction for additional connector front-end details.

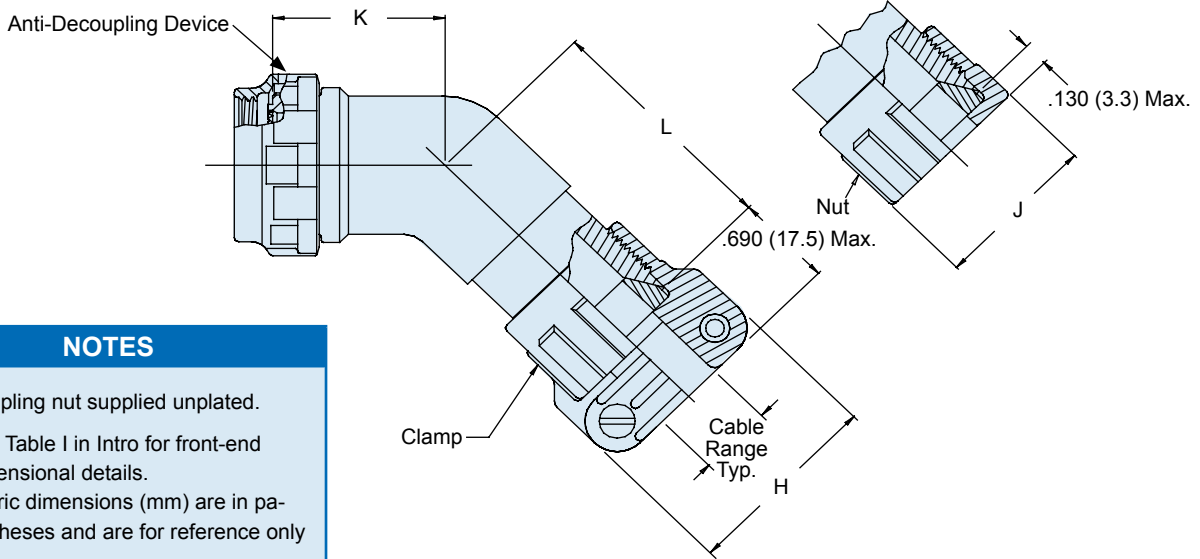
TABLE III: FINISH

Symbol	Finish Description
XM	2000 Hour Corrosion Resistant Electroless Nickel
XMT	2000 Hour Corrosion Resistant Ni-PTFE, Nickel-Fluorocarbon Polymer. 1000 Hour Grey™
XW	2000 Hour Corrosion Resistant Cadmium/Olive Drab over Electroless Nickel

**380-099**  
**Composite Cone and Ring Style**  
**EMI/RFI Shield Termination Backshell**  
**with Self-Locking Coupling Nut and Strain Relief Clamp**



Composite Backshells



**A**

- NOTES**
1. Coupling nut supplied unplated.
  2. See Table I in Intro for front-end dimensional details.
  3. Metric dimensions (mm) are in parentheses and are for reference only

**TABLE II: CONNECTOR SHELL SIZE (CONT.)**

Shell Size For Connector Designator		K		L		Max Entry Dash No. *
A & F/L	H	±.06 (1.5)	±.06 (1.5)	±.06 (1.5)	±.06 (1.5)	
08	09	.72 (18.3)	.88 (22.4)	.88 (22.4)	.88 (22.4)	10
10	11	.75 (19.1)	.94 (23.9)	.94 (23.9)	.94 (23.9)	12
12	13	.75 (19.1)	1.00 (25.4)	1.00 (25.4)	1.00 (25.4)	14
14	15	.76 (19.3)	1.03 (26.2)	1.03 (26.2)	1.03 (26.2)	16
16	17	.78 (19.8)	1.06 (26.9)	1.06 (26.9)	1.06 (26.9)	20
18	19	.79 (20.1)	1.07 (27.2)	1.07 (27.2)	1.07 (27.2)	20
20	21	.82 (20.8)	1.09 (27.7)	1.09 (27.7)	1.09 (27.7)	22
22	23	.86 (21.8)	1.14 (29.0)	1.14 (29.0)	1.14 (29.0)	24
24	25	.92 (23.4)	1.17 (29.7)	1.17 (29.7)	1.17 (29.7)	28

\* Consult factory for additional entry sizes available.

**TABLE IV: CABLE ENTRY**

Dash No.	H		J		Cable Range *			
	±.06 (1.5)	±.06 (1.5)	±.06 (1.5)	±.06 (1.5)	Minimum		Maximum	
10	.94 (23.9)	.80 (20.3)	.20 (5.1)	.25 (6.4)	.20 (5.1)	.25 (6.4)	.25 (6.4)	.25 (6.4)
12	1.17 (29.7)	.93 (23.6)	.29 (5.1)	.38 (9.7)	.29 (5.1)	.38 (9.7)	.38 (9.7)	.38 (9.7)
14	1.28 (32.5)	1.06 (26.9)	.40 (10.1)	.44 (11.2)	.40 (10.1)	.44 (11.2)	.44 (11.2)	.44 (11.2)
16	1.41 (35.8)	1.22 (31.0)	.48 (12.2)	.63 (15.9)	.48 (12.2)	.63 (15.9)	.63 (15.9)	.63 (15.9)
18	1.50 (38.1)	1.24 (31.5)	.55 (14.0)	.69 (17.5)	.55 (14.0)	.69 (17.5)	.69 (17.5)	.69 (17.5)
20	1.56 (39.6)	1.37 (34.8)	.64 (16.3)	.75 (19.1)	.64 (16.3)	.75 (19.1)	.75 (19.1)	.75 (19.1)
22	1.69 (42.9)	1.49 (37.8)	.72 (18.3)	.88 (22.2)	.72 (18.3)	.88 (22.2)	.88 (22.2)	.88 (22.2)
24	1.81 (46.0)	1.62 (41.1)	.79 (20.0)	1.00 (25.4)	.79 (20.0)	1.00 (25.4)	1.00 (25.4)	1.00 (25.4)
28	1.91 (48.5)	1.68 (42.7)	.89 (20.3)	1.13 (28.6)	.89 (20.3)	1.13 (28.6)	1.13 (28.6)	1.13 (28.6)
32	2.02 (51.3)	1.82 (46.2)	.96 (24.4)	1.25 (31.8)	.96 (24.4)	1.25 (31.8)	1.25 (31.8)	1.25 (31.8)

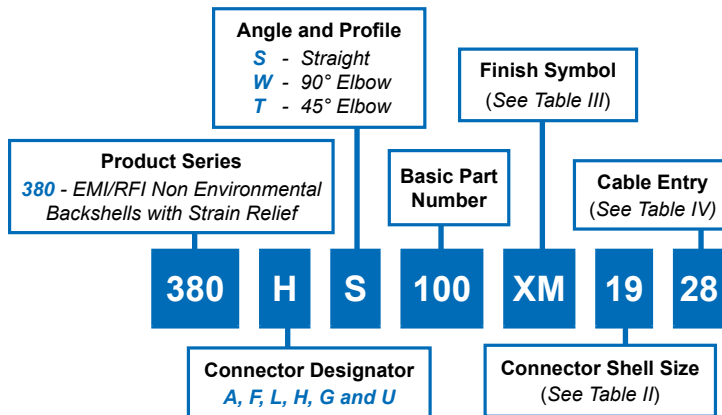
\* Cable range equals diameter of cable outer jacket.



# 380-100 Composite Cone and Ring Style EMI/RFI Shield Termination Backshell with Self-Locking Rotatable Coupling and Qwik Clamp

A

CONNECTOR DESIGNATOR:	
<b>A</b>	MIL-DTL-5015, -26482 Series II, and -83723 Series I and III
<b>F</b>	MIL-DTL-38999 Series I, II
<b>L</b>	MIL-DTL-38999 Series 1.5 (JN1003)
<b>H</b>	MIL-DTL-38999 Series III and IV
<b>G</b>	MIL-DTL-28840
<b>U</b>	DG123 and DG123A
<b>SELF-LOCKING</b>	
<b>ROTATABLE COUPLING</b>	
<b>STANDARD PROFILE</b>	



Anti-Decoupling Device

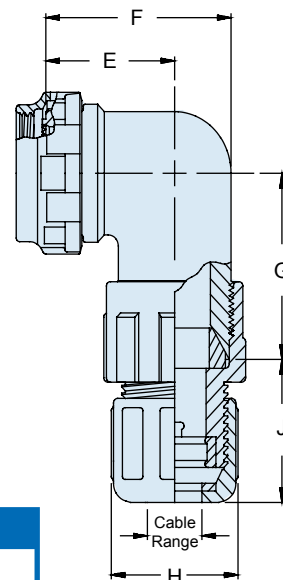
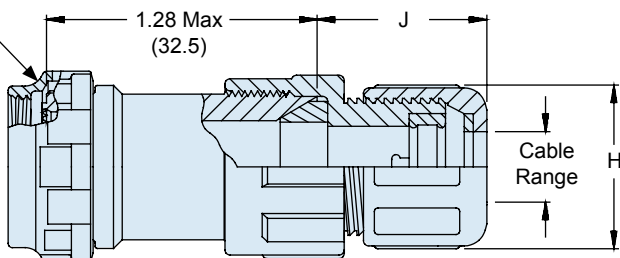


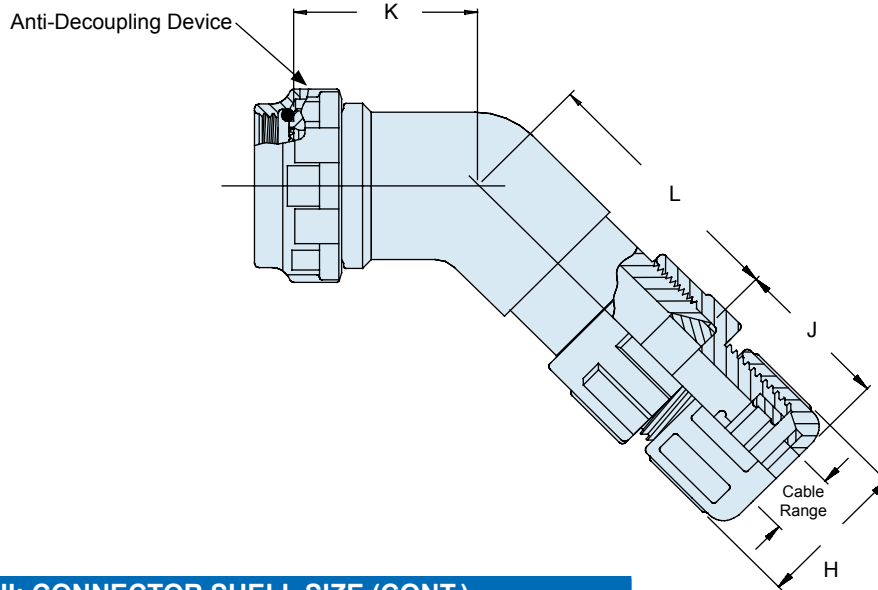
TABLE II: CONNECTOR SHELL SIZE

Shell Size For					E	F	G	Max Entry
Connector Designator								
A	F/L	H	G	U	± .06 (1.5)	± .09 (2.3)	± .09 (2.3)	Dash No.**
08	08	09	-	-	.69 (17.5)	.88 (22.4)	1.06 (26.9)	08
10	10	11	-	08	.75 (19.1)	1.00 (25.4)	1.13 (28.7)	12
12	12	13	11	10	.81 (20.6)	1.13 (28.7)	1.19 (30.2)	16
14	14	15	13	12	.88 (22.4)	1.31 (33.3)	1.25 (31.8)	20
16	16	17	15	14	.94 (23.9)	1.38 (35.1)	1.31 (33.3)	24
18	18	19	17	16	.97 (24.6)	1.44 (36.6)	1.34 (34.0)	28
20	20	21	19	18	1.06 (26.9)	1.63 (41.4)	1.44 (36.6)	32
22	22	23	-	20	1.13 (28.7)	1.75 (44.5)	1.50 (38.1)	36
24	24	25	23	22	1.19 (30.2)	1.88 (47.8)	1.56 (39.6)	40
28	-	-	25	24	1.34 (34.0)	2.13 (54.1)	1.66 (42.2)	44

\*\*Consult factory for additional entry sizes available.  
See introduction for additional connector front-end details.

US PATENT 5211576

**380-100**  
**Composite Cone and Ring Style**  
**EMI/RFI Shield Termination Backshell**  
**with Self-Locking Rotatable Coupling and Qwik Clamp**



**TABLE II: CONNECTOR SHELL SIZE (CONT.)**

Shell Size For Connector Designator		K		L		Max Entry Dash No. *
A & F/L	H	± .06	(1.5)	± .06	(1.5)	
08	09	.72	(18.3)	.88	(22.4)	08
10	11	.75	(19.1)	.94	(23.9)	12
12	13	.75	(19.1)	1.00	(25.4)	16
14	15	.76	(19.3)	1.03	(26.2)	20
16	17	.78	(19.8)	1.06	(26.9)	24
18	19	.79	(20.1)	1.07	(27.2)	28
20	21	.82	(20.8)	1.09	(27.7)	32
22	23	.86	(21.8)	1.14	(29.0)	36
24	25	.92	(23.4)	1.17	(29.7)	40

\* Consult factory for additional entry sizes available.

**NOTES**

1. Coupling nut supplied unplated.
2. See Table I in Intro for front-end dimensional details.
3. Metric dimensions (mm) are in parentheses and are for reference only.

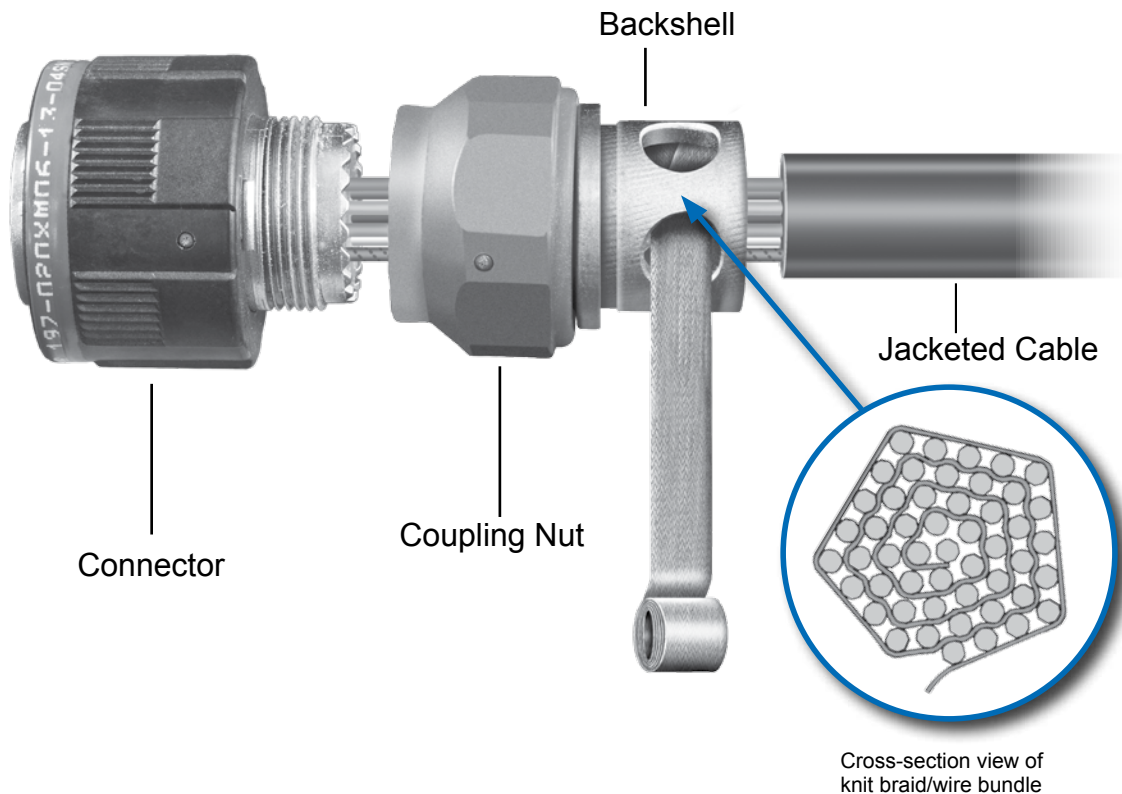
**TABLE IV: CABLE ENTRY**

Entry Code	H (Max)	J (Max)	Cable Range			
			Minimum	Maximum	Minimum	Maximum
08	.72 (18.3)	.87 (22.1)	.10 (2.5)	.25 (6.4)	.10 (2.5)	.25 (6.4)
12	.91 (23.1)	1.01 (25.7)	.20 (5.1)	.38 (9.7)	.20 (5.1)	.38 (9.7)
16	1.09 (27.7)	1.11 (28.2)	.33 (8.4)	.50 (12.7)	.33 (8.4)	.50 (12.7)
20	1.22 (31.0)	1.11 (28.2)	.45 (11.4)	.63 (15.9)	.45 (11.4)	.63 (15.9)
24	1.34 (34.0)	1.11 (28.2)	.52 (13.2)	.75 (19.1)	.52 (13.2)	.75 (19.1)
28	1.53 (38.9)	1.26 (32.0)	.64 (16.3)	.88 (22.2)	.64 (16.3)	.88 (22.2)
32	1.72 (43.7)	1.41 (35.8)	.77 (19.6)	1.00 (25.4)	.77 (19.6)	1.00 (25.4)
36	1.85 (47.0)	1.41 (35.8)	.86 (21.8)	1.13 (28.6)	.86 (21.8)	1.13 (28.6)
40	1.97 (50.0)	1.41 (35.8)	.98 (24.9)	1.25 (31.8)	.98 (24.9)	1.25 (31.8)
44	2.09 (53.1)	1.53 (38.9)	1.13 (28.6)	1.38 (34.9)	1.13 (28.6)	1.38 (34.9)

**TABLE III: FINISH**

Symbol	Finish Description
XM	2000 Hour Corrosion Resistant Electroless Nickel
XMT	2000 Hour Corrosion Resistant Ni-PTFE, Nickel-Fluorocarbon Polymer. <i>1000 Hour Grey™</i>
XW	2000 Hour Corrosion Resistant Cadmium/Olive Drab over Electroless Nickel

A

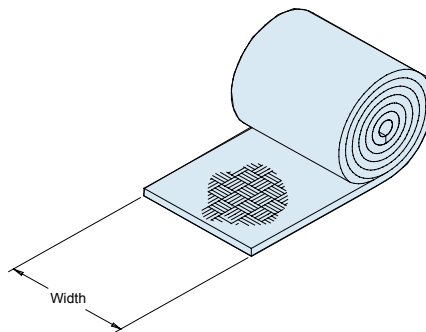


1. Temporarily assemble backshell to connector.
2. If cable is jacketed, insert cable into backshell and bottom against connector. Using the end of the backshell as a guide, mark the location of solder sleeves and/or pigtail breakouts on the cable.
3. Disassemble backshell from connector and stage it up the cable for installation after wire termination is complete.
4. Trim cable jacket at marked location from step 2 above and pull out pigtails and/or apply solder sleeves. Terminate contacts to wires in accordance with established practices.
5. Insert contacts into connector in accordance with established practices.
6. Pull braid forward and wrap the knit braid around individual wires in groups of two or three, ensuring that the knitmesh braid is in contact with all exposed braids (see cross-section illustration).
7. Pull the knit braid tightly around the wire bundle and pass through one of the holes in the backshell.
8. Screw the backshell partially onto the connector, ensuring that the interface teeth *do not* engage—allowing the backshell to rotate freely.

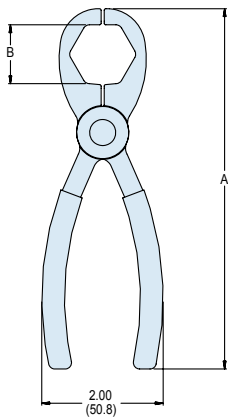
# Knit Braid Backshell Assembly Instructions



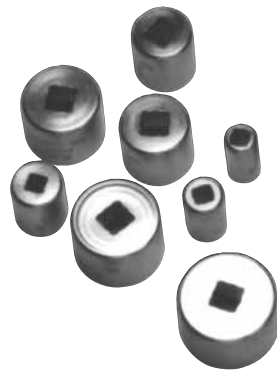
9. Rotate the backshell so that the knit braid is drawn into the backshell. Maintain firm pressure on the free knit braid during this step to provide tight coverage. Continue rotating until the knit braid is wound tightly into the backshell and further rotation becomes difficult.
10. Cut the braid flush with the backshell O.D. Rotate the backshell body 1/4 turn to ensure that the end of the braid is out of sight.
11. Tighten the backshell fully onto the connector using established procedures and torque values.



107-044  
Nickel Plated Copper Knit Braid  
(see product page for details)



600-157  
Stainless Steel Composite  
Hex Coupling Wrench



Plug and Receptacle  
Holding Tools  
for 1/4" and 3/8" Socket



600-161  
Hand Held Digital  
Torque Wrench

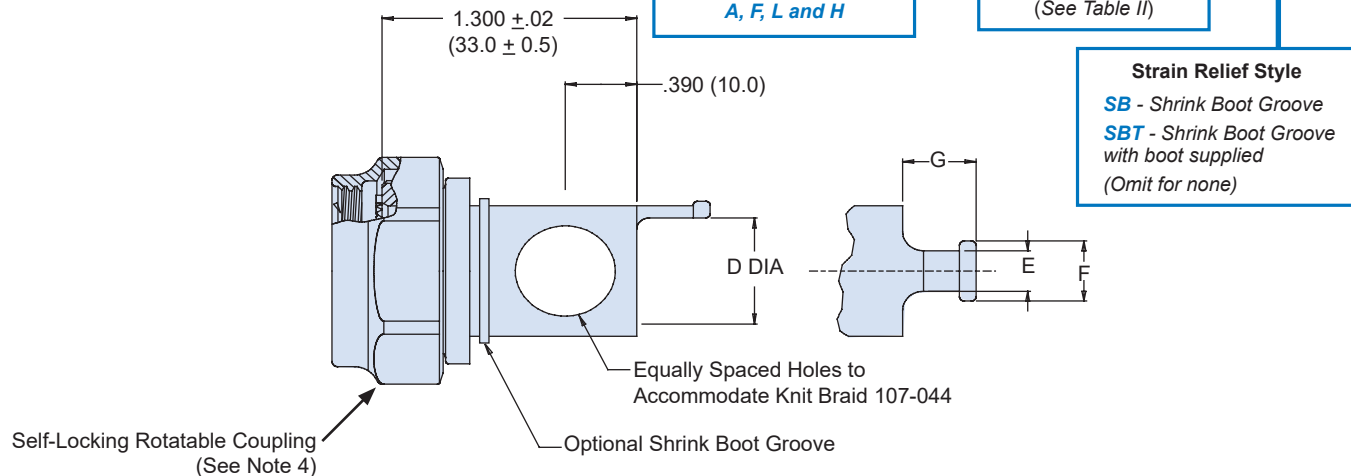
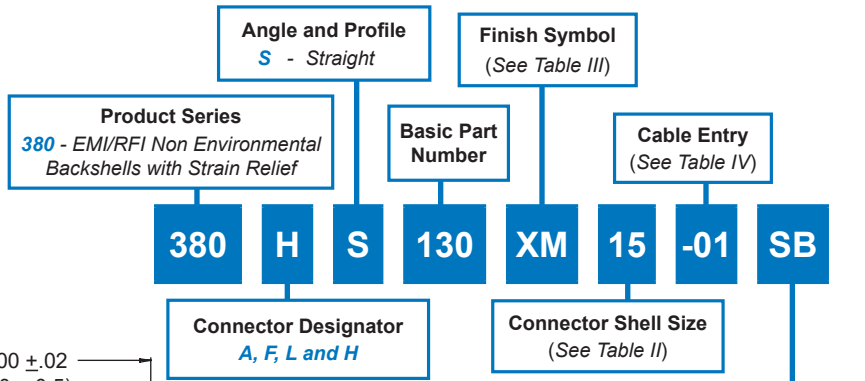
COMPOSITE COUPLING TORQUE VALUES	
Shell Size Reference	Composite Torque (Inch-Pounds)
08/09	35
10/11	35
12/13	40
14/15	40
16/17	40
18/19	40
20/21	80
22/23	80
24/25	80
28	120
32	120
36	120



# 380-130 Composite Knit-Braid Style EMI/RFI Shield Termination Backshell with Qwik-Ty® and Rotatable Coupling

A

CONNECTOR DESIGNATOR:	
A	MIL-DTL-5015, -26482 Series II, and -83723 Series I and III
F	MIL-DTL-38999 Series I, II
L	MIL-DTL-38999 Series 1.5 (JN1003)
H	MIL-DTL-38999 Series III and IV
ROTATABLE COUPLING	



Shell Size	Max Entry Code**	Shell Size			
		F/L	H	Code**	Max Entry Code**
08	00	08	09	01	
10	01	10	11	02	
12	02	12	13	03	
14	03	14	15	04	
16	04	16	17	05	
18	05	18	19	06	
20	06	20	21	07	
22	07	22	23	08	
24	08	24	25	09	

Entry Code**	D	E	F	G	Number of Holes
	±.010 (0.25)	±.020 (0.50)	±.020 (0.50)	±.020 (0.50)	
00	.268 (6.8)	.187 (4.8)	.312 (7.9)	.512 (13.0)	2*
01	.354 (9.0)	.187 (4.8)	.312 (7.9)	.512 (13.0)	2**
02	.472 (12.0)	.187 (4.8)	.312 (7.9)	.512 (13.0)	2**
03	.591 (15.0)	.187 (4.8)	.312 (7.9)	.630 (16.0)	2*
04	.709 (18.0)	.219 (5.6)	.369 (9.4)	.630 (16.0)	2*
05	.837 (21.3)	.219 (5.6)	.369 (9.4)	.630 (16.0)	2*
06	.945 (24.0)	.219 (5.6)	.369 (9.4)	.630 (16.0)	2*
07	1.063 (27.0)	.250 (6.4)	.437 (11.1)	.630 (16.0)	4*
08	1.191 (30.3)	.250 (6.4)	.437 (11.1)	.630 (16.0)	4*
09	1.319 (33.5)	.250 (6.4)	.437 (11.1)	.630 (16.0)	4*

\*Oval Holes, .256 (6.5) x .512 (13.0) \*\*Oval Holes, .315 (8.0) x .512 (13.0) \*Circular Holes, .512 (13.0) Diameter.

Symbol	Finish Description
XM	2000 Hour Corrosion Resistant Electroless Nickel
XMT	2000 Hour Corrosion Resistant Ni-PTFE, Nickel-Fluorocarbon Polymer. 1000 Hour Grey™
XW	2000 Hour Corrosion Resistant Cadmium/Olive Drab over Electroless Nickel

- |    |  |
|----|--|
| 1. | For effective grounding, connector with conductive finish should be used.        |
| 2. | Coupling nut supplied unplated.  |
| 3. | Metric dimensions (mm) are in parentheses and are for reference only.            |
| 4. | Connector Code H supplied with black coupling nut.                               |
| 5. | Consult factory for additional entry sizes available.                            |
| 6. | For angled part requirements, use in conjunction with Glenair 327-060 Extenders. |
| 7. | See Table I in Intro for additional connector front-end dimensional details.     |



# 380-131 Composite Knit-Braid Style EMI/RFI Shield Termination Backshell with Strain-Relief Clamp and Rotatable Coupling



Composite Backshells

A

CONNECTOR DESIGNATOR:	
<b>A</b>	MIL-DTL-5015, -26482 Series II, and -83723 Series I and III
<b>F</b>	MIL-DTL-38999 Series I, II
<b>L</b>	MIL-DTL-38999 Series 1.5 (JN1003)
<b>H</b>	MIL-DTL-38999 Series III and IV
<b>ROTATABLE COUPLING</b>	

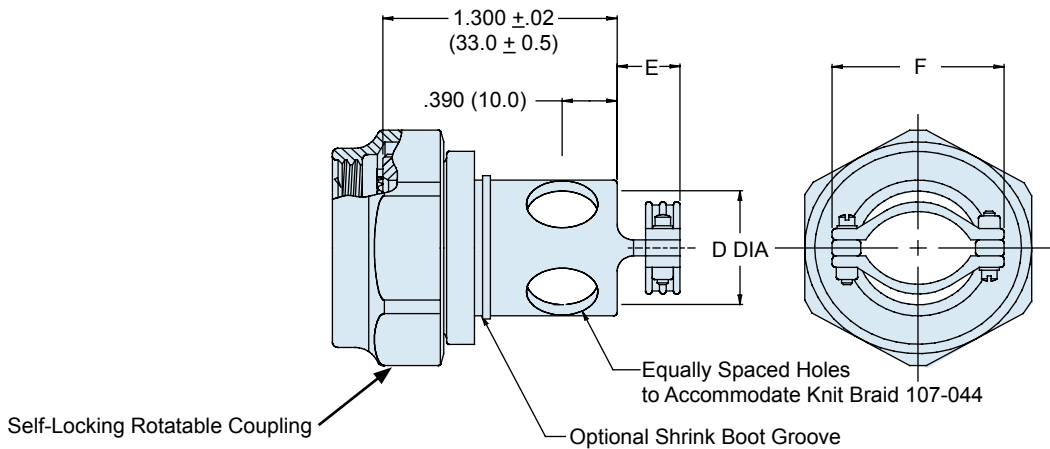
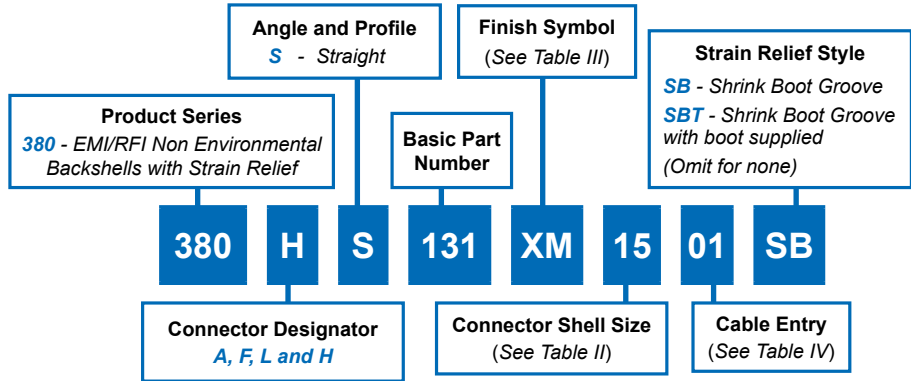


TABLE II: SHELL SIZE			
Shell Size	Max Entry Code**	Shell Size	Max Entry Code**
A		F/L H	
08	00	08 09	01
10	01	10 11	02
12	02	12 13	03
14	03	14 15	04
16	04	16 17	05
18	05	18 19	06
20	06	20 21	07
22	07	22 23	08
24	08	24 25	09

TABLE IV: CABLE ENTRY					
Entry Code**	D ±.010 (0.25)	E ±.020 (0.50)	F ±.060 (1.5)	Number of Holes	
00	.268 (6.8)	.512 (13.0)	.880 (22.4)	2*	
01	.354 (9.0)	.512 (13.0)	.940 (23.9)	2**	
02	.472 (12.0)	.512 (13.0)	1.170 (29.7)	2**	
03	.591 (15.0)	.630 (16.0)	1.280 (32.5)	2*	
04	.709 (18.0)	.630 (16.0)	1.410 (35.8)	2*	
05	.837 (21.3)	.630 (16.0)	1.500 (38.1)	2*	
06	.945 (24.0)	.630 (16.0)	1.560 (39.6)	2*	
07	1.063 (27.0)	.630 (16.0)	1.690 (42.9)	4*	
08	1.191 (30.3)	.630 (16.0)	1.820 (46.2)	4*	
09	1.319 (33.5)	.630 (16.0)	1.910 (48.5)	4*	

\*Oval Holes, .256 (6.5) x .512 (13.0) \*\*Oval Holes, .315 (8.0) x .512 (13.0)  
\*Circular Holes, .512 (13.0) Diameter.

- ### APPLICATION NOTES
1. Coupling nut and saddle bars supplied unplated.
  2. Metric dimensions (mm) are in parentheses and are for reference only.
  3. Consult factory for additional entry sizes available.
  4. For angled part requirements, use in conjunction with Glenair 327-060 Extenders.
  5. See Table I in Intro for additional connector front-end dimensions.

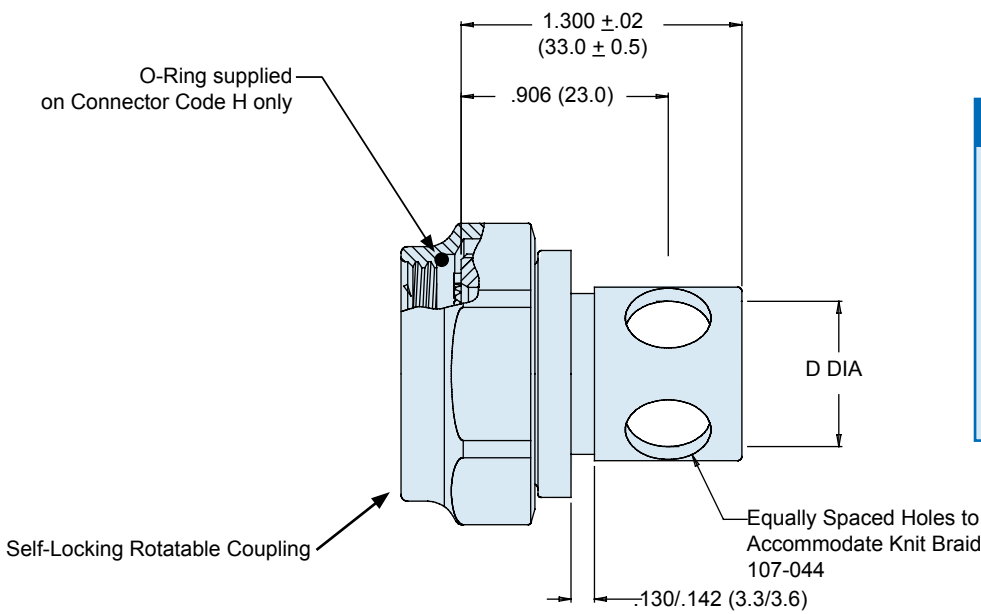
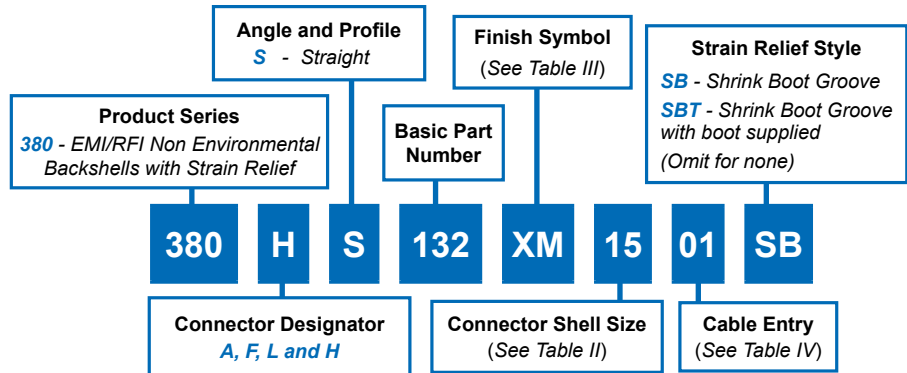
TABLE III: FINISH	
Symbol	Finish Description
XM	2000 Hour Corrosion Resistant Electroless Nickel
XMT	2000 Hour Corrosion Resistant Ni-PTFE, Nickel-Fluorocarbon Polymer. <i>1000 Hour Grey™</i>
XW	2000 Hour Corrosion Resistant Cadmium/Olive Drab over Electroless Nickel



# 380-132 Composite Knit-Braid Style EMI/RFI O-Ring Equipped Shield Termination Backshell with Shrink Boot Adapter and Rotatable Coupling

A

CONNECTOR DESIGNATOR:	
<b>A</b>	MIL-DTL-5015, -26482 Series II, and -83723 Series I and III
<b>F</b>	MIL-DTL-38999 Series I, II
<b>L</b>	MIL-DTL-38999 Series 1.5 (JN1003)
<b>H</b>	MIL-DTL-38999 Series III and IV
<b>ROTATABLE COUPLING</b>	



- ### APPLICATION NOTES
1. Coupling nut and saddle bars supplied unplated.
  2. Consult factory for additional entry sizes available.
  3. For angled part requirements, use in conjunction with Glenair 327-060 Extenders.
  4. See Table I in Intro for additional front-end dimensional details.

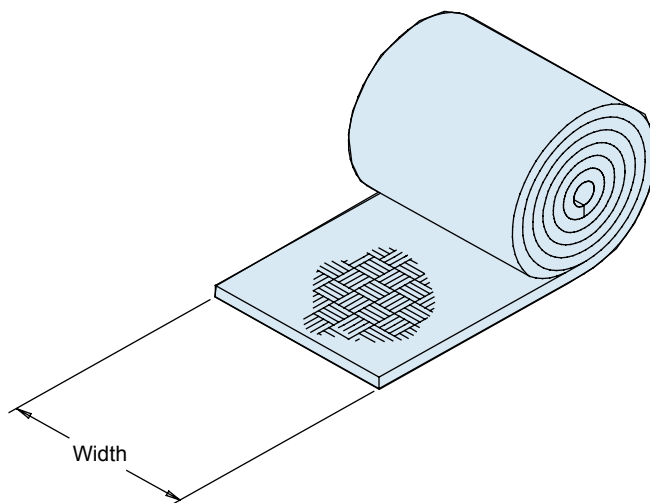
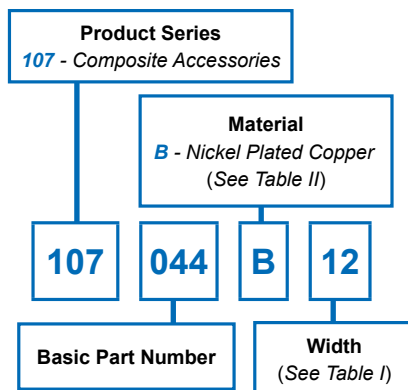
Shell Size	Max Entry Code**	Shell Size		Max Entry Code**
		F/L	H	
08	00	08	09	01
10	01	10	11	02
12	02	12	13	03
14	03	14	15	04
16	04	16	17	05
18	05	18	19	06
20	06	20	21	07
22	07	22	23	08
24	08	24	25	09

Entry Code**	D ±.010 (0.25)	Number of Holes
00	.268 (6.8)	2*
01	.354 (9.0)	2**
02	.472 (12.0)	2**
03	.591 (15.0)	2*
04	.709 (18.0)	2*
05	.837 (21.3)	2*
06	.945 (24.0)	2*
07	1.063 (27.0)	4*
08	1.191 (30.3)	4*
09	1.319 (33.5)	4*

Symbol	Finish Description
XM	2000 Hour Corrosion Resistant Electroless Nickel
XMT	2000 Hour Corrosion Resistant Ni-PTFE, Nickel-Fluorocarbon Polymer. 1000 Hour Grey™
XW	2000 Hour Corrosion Resistant Cadmium/Olive Drab over Electroless Nickel

\*Oval Holes, .256 (6.5) x .512 (13.0)  
 \*\*Oval Holes, .315 (8.0) x .512 (13.0)  
 \*Circular Holes, .512 (13.0) Diameter.

**107-044**  
**EMI/RFI Nickel Plated Copper Knit Braid**  
 for use with Knit Braid Adapters 380-130, 380-131 and 380-132



Width Code	Width	Strands Diameter	Approx. No. of Stitches per CM on Length	Approx. No. of Stitches per CM Across Length
12	.472 (12.0)	.006 (0.2)	.138 (3.5)	.173 (4.4)

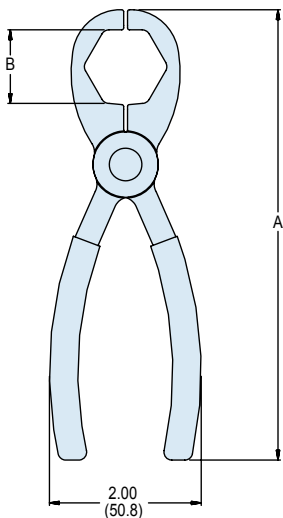
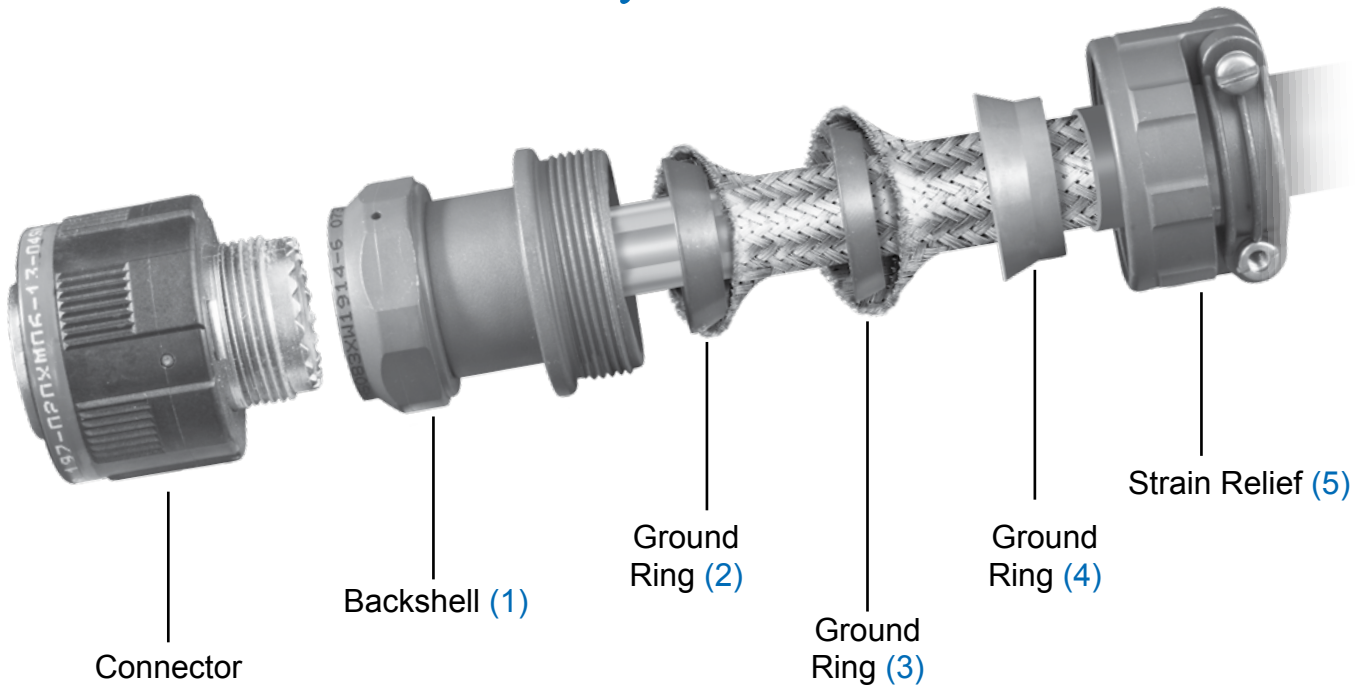
B *	Nickel Plated Copper
-----	----------------------

\* For other material options and sizes please consult factory

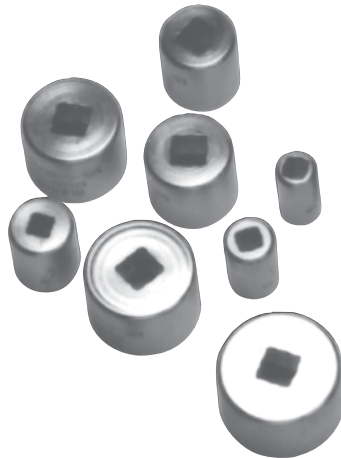
- APPLICATION NOTES**
1. The woven braid is to be used with 360° RFI/EMI shield terminations.
  2. Metric dimensions (mm) are in parentheses and are for reference only

## Series 380 EMI/RFI Non-Environmental (Type E) Assembly Instructions

A



(6) 600-157  
Stainless Steel Composite  
Hex Coupling Wrench



(7) Plug and Receptacle  
Holding Tools  
for 1/4" and 3/8" Socket



(8) 600-161  
Hand Held Digital  
Torque Wrench

COMPOSITE COUPLING TORQUE VALUES	
Shell Size Reference	Composite Torque (Inch-Pounds)
08/09	35
10/11	35
12/13	40
14/15	40
16/17	40
18/19	40
20/21	80
22/23	80
24/25	80
28	120
32	120
36	120

**Series 380 (Type E) Multi-Shield EMI/RFI  
Non-Environmental  
Backshell Assembly Instructions**



The following suggested procedure serves as a guide for the proper assembly and installation of Glenair EMI/RFI Non-Environmental Backshells (Type E shield termination). It is recommended that trial samples of appropriate cables or harnesses be used to determine proper trim dimensions of the outer shield and individual conductors. This procedure is for the three ring style.

**NOTE: *As with any electrical connector assembly procedure, be sure to use the proper tools. For convenient, reliable assembly of the connector and backshell, it is suggested that Glenair's connector holding tools, strap wrenches and connector pliers be used.***

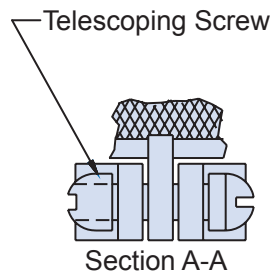
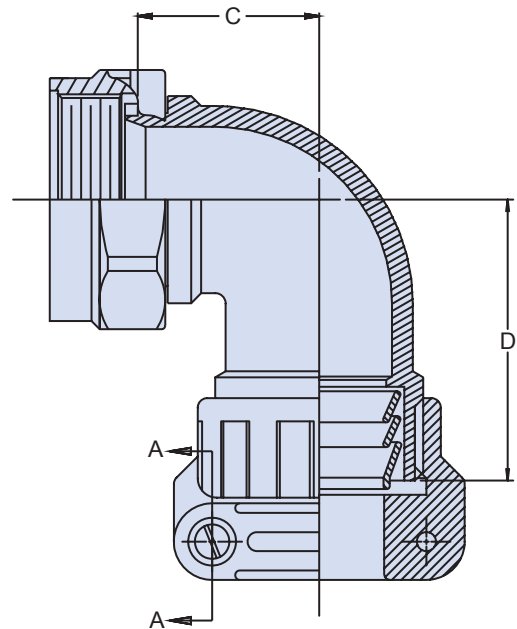
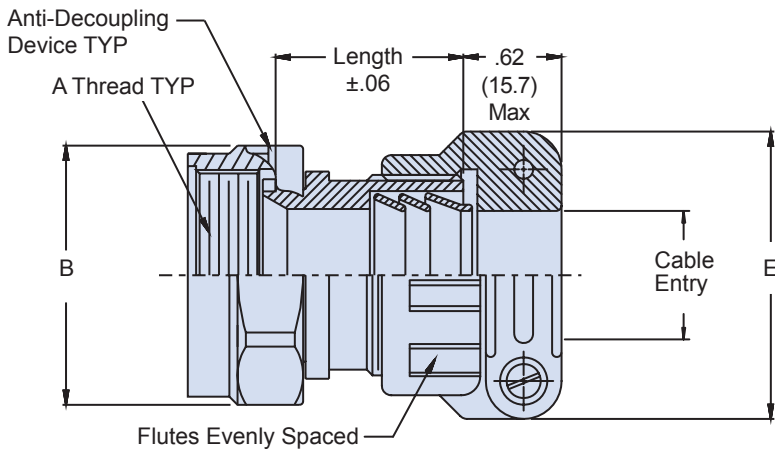
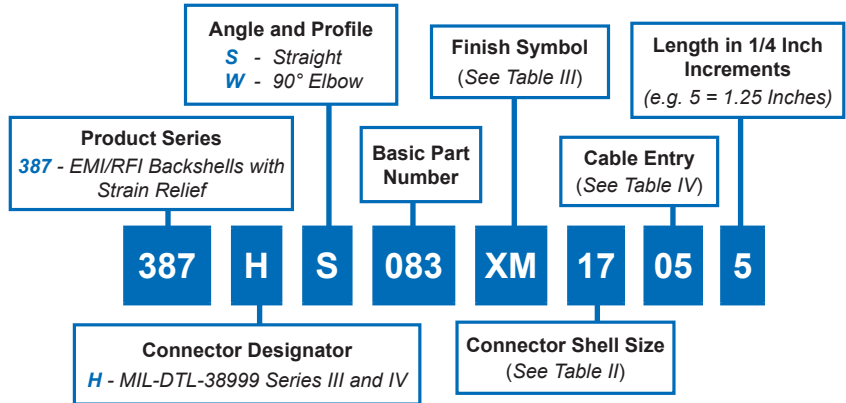
1. Temporarily assemble backshell (1) to connector.
2. Remove backshell from connector and stage it, along with the ground rings (2), (3), (4) and strain relief clamp (2), up the cable for installation after wires are terminated to the connector contacts.
3. Insert cable or harness into backshell (1) and bottom against connector. Hold cable in position and mark outer shield at rear end of backshell (1).
4. Remove backshell from connector and place on cable with items in step two above.
5. Trim outer shield at mark made in step three above.
6. Extract shield pigtail from individual conductor's. Tape or tie pigtails to the bundle.
7. Prepare and terminate contacts to individual conductors in accordance with established practices. (Crimp or solder in place.)
8. Slide backshell (1) forward to connector, and tighten securely.
9. Remove tape or untie pigtails from bundle. Slide ground ring (2) forward to flared-out pigtails. Fold pigtails back over ground ring (2) tie back to bundle leaving about 1/2" to 1" slack.
10. Bring ground ring (3) forward to overall braid, fold braid back over ring (3), push forward onto ring (2). Slide ground ring (4) onto overall braid and onto ring (3). . . push all three rings forward into the counter bore at the rear of backshell (1).
11. Thread backshell (1) onto the connector and tighten securely. Glenair recommends the use of the appropriate sized series 600-157 composite hex coupling wrench (6) to prevent damage to the composite backshell coupling nut. For added convenience in assembly, an appropriately sized series 600-005 connector holding tool (7) is recommended, as well as Glenair digital torque wrench (8). Tighten strain relief saddles securely on cable or harness (see saddle clamp assembly procedure). This will then provide a good ground or bonding joint for both the individual and over-all shields. (For the two ring style, ground ring (3) is omitted, and above steps I or J is utilized with either overall or individual braids).

# 387-083 Composite Multi-Shield Cone and Ring Style EMI/RFI Shield Termination Backshell with Self-Locking Rotatable Coupling and Strain Relief

A

CONNECTOR DESIGNATOR:	
<b>H</b>	MIL-DTL-38999 Series III and IV
<b>SELF-LOCKING</b>	
<b>ROTATABLE COUPLING</b>	
<b>STANDARD PROFILE</b>	

Note: See Table I in Intro for Front-End Dimensional Details



- NOTES**
1. See Table I in Intro for front-end dimensional details.
  2. Coupling nut supplied plated.
  3. Metric dimensions (mm) are in parenthesis and are for reference only.

**387-083**  
**Composite Multi-Shield Cone and Ring Style**  
**EMI/RFI Shield Termination Backshell**  
**with Self-Locking Rotatable Coupling and Strain Relief**



TABLE II: SHELL SIZE						
Shell Size	Shell Size Code	A Thread ISO Metric	B Max	C ±.078 (2.0)	D ±.078 (2.0)	Max Available Entry
09	A	M12x 1-6H	.94 (23.9)	.722 (18.3)	1.750 (44.4)	04
11	B	M15x 1-6H	1.06 (26.9)	.784 (19.9)	1.820 (46.2)	06
13	C	M18x 1-6H	1.17 (29.7)	.816 (20.7)	1.860 (47.2)	08
15	D	M22x 1-6H	1.29 (32.8)	.878 (22.3)	1.880 (47.8)	10
17	E	M25x 1-6H	1.42 (36.1)	.942 (23.9)	1.942 (49.3)	12
19	F	M28x 1-6H	1.54 (39.1)	1.003 (25.5)	2.000 (50.8)	14
21	G	M31x 1-6H	1.67 (42.4)	1.037 (26.3)	2.062 (52.4)	16
23	H	M34x 1-6H	2.01 (51.1)	1.116 (28.3)	2.194 (55.7)	17
25	J	M37x 1-6H	2.12 (53.8)	1.194 (30.3)	2.257 (57.3)	20

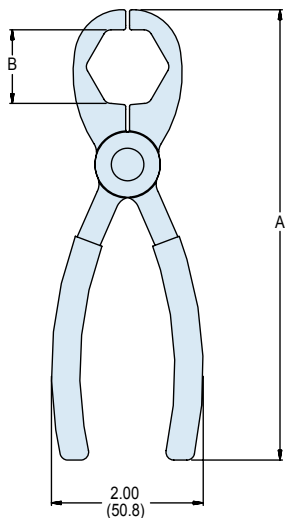
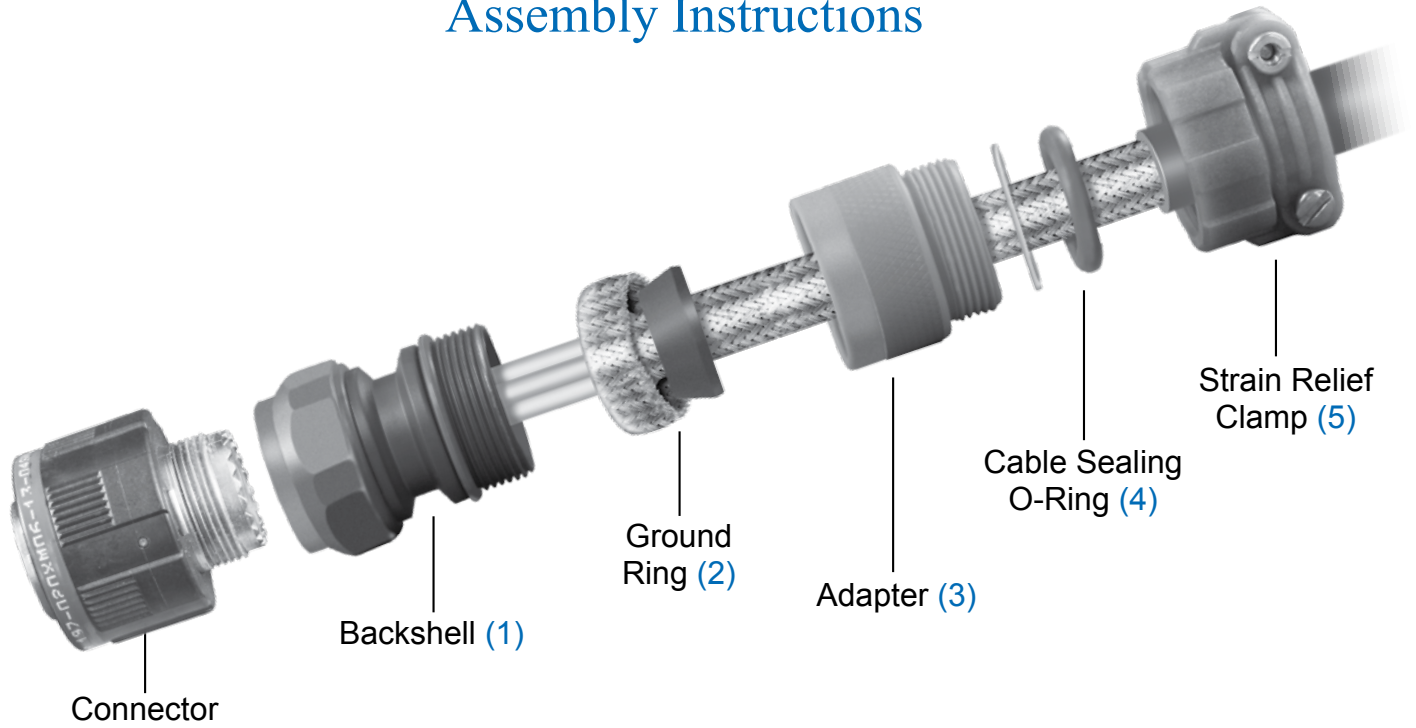
TABLE IV: CABLE ENTRY		
Dash Number	E Max	Cable Entry ±.039 (1.0)
04	1.125 (28.6)	.312 (7.9)
06	1.250 (31.8)	.437 (11.1)
08	1.312 (33.3)	.500 (12.7)
10	1.438 (36.5)	.625 (15.9)
12	1.625 (41.3)	.750 (19.1)
14	1.688 (42.9)	.874 (22.2)
16	1.750 (44.5)	.937 (23.8)
17	1.906 (48.5)	1.094 (27.8)
20	2.062 (52.4)	1.250 (31.8)

TABLE III: FINISH	
Symbol	Finish Description
XM	2000 Hour Corrosion Resistant Electroless Nickel
XMT	2000 Hour Corrosion Resistant Ni-PTFE, Nickel-Fluorocarbon Polymer. <i>1000 Hour Grey™</i>
XW	2000 Hour Corrosion Resistant Cadmium/Olive Drab over Electroless Nickel

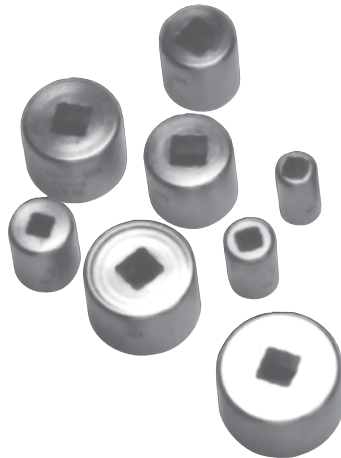
BACKSHELL WEIGHT					
Symbol "S" Straight Weight Table			Symbol "W" 90° Weight Table		
Shell Size	Dash Number	Max Weight (KG)	Shell Size	Dash Number	Max Weight (KG)
09	04	.0296	09	04	.0326
11	06	.0327	11	06	.0360
13	08	.0370	13	08	.0420
15	10	.0430	15	10	.0480
17	12	.0500	17	12	.0550
19	12	.0560	19	12	.0610
21	16	.0640	21	16	.0690
23	16	.0700	23	16	.0750
25	20	.0750	25	20	.0800

# Series 390 (Single Shield) EMI/RFI Environmental Assembly Instructions

A



(6) 600-157  
Stainless Steel Composite Hex Coupling Wrench



(7) Plug and Receptacle Holding Tools for 1/4" and 3/8" Socket



(8) 600-161 Hand Held Digital Torque Wrench

COMPOSITE COUPLING TORQUE VALUES	
Shell Size Reference	Composite Torque (Inch-Pounds)
08/09	35
10/11	35
12/13	40
14/15	40
16/17	40
18/19	40
20/21	80
22/23	80
24/25	80
28	120
32	120
36	120



Series 390 (Single Shield) EMI/RFI  
Environmental Backshell  
Assembly Instructions



The following suggested procedure serves as a guide for proper assembly and installation of straight Glenair Series 390 EMI/RFI Cable Sealing Backshells for use with jacketed cables and a single overall EMI shield. It is recommended that trial samples of appropriate cables be used to determine proper trim dimensions of the cable jacket, individual conductors and shielding.

**NOTE: As with any electrical connector assembly procedure, be sure to use the proper tools. For convenient reliable assembly of the connector and backshell, it is suggested that Glenair's connector holding tools, strap wrenches and connector pliers be used.**

1. Temporarily assemble backshell (1) to connector.
2. Place the ground ring (2), adapter, o-ring seal (plus washer if provided) and strain relief clamp on the cable in the sequence shown. You are staging these components on the cable for installation after wires are terminated to the connector contacts.
3. Insert cable into backshell (1) and bottom against connector. Hold cable in position and mark cable jacket at rear end of backshell.
4. Remove backshell from connector and place on cable with components from step two above
5. Trim cable jacket at a point 3/4 inch toward connector from mark made in step two above, exposing cable shielding.
6. Prepare and terminate wires in accordance with established practices.
7. Assemble backshell (1) to connector and tighten securely using appropriate tools.
8. Flare EMI shield completely over grounding ring. Manipulate shield into the conical counter-bore in the adapter and capture in place with the ground ring.
9. Tighten adapter in place using TG70 strap wrench.
10. Slide O-ring and washer (if provided) against adapter (3).
11. Thread strain relief clamp (5) firmly in place.
12. Tighten saddle bar clamps until they bottom against saddle clamp ears (see saddle clamp assembly procedure).



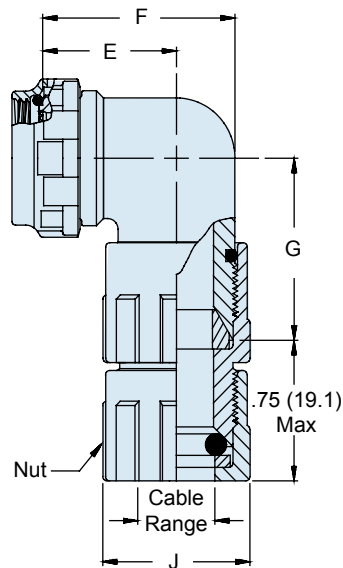
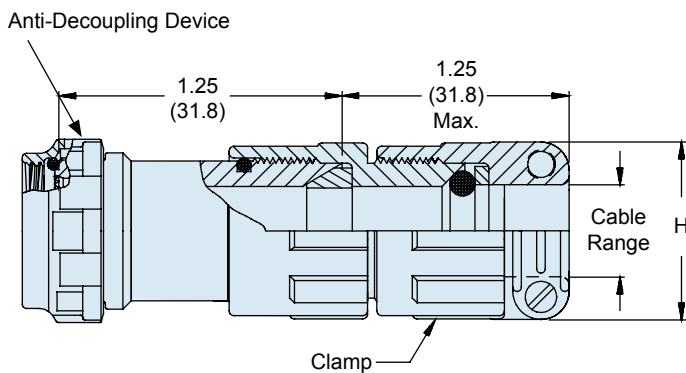
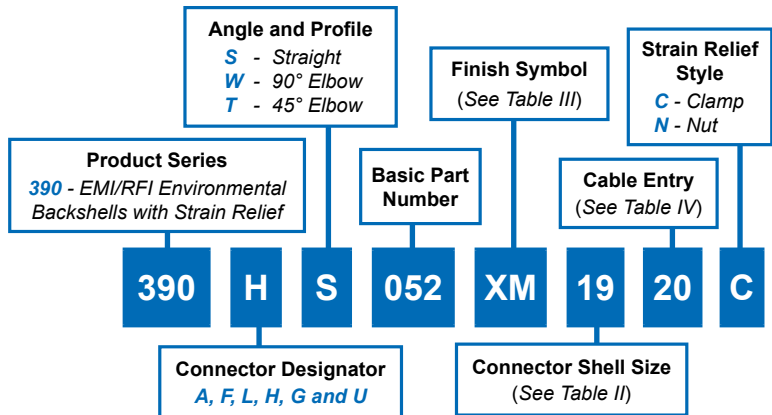
# 390-052

## Composite Cone and Ring Style

### EMI/RFI Environmental Shield Termination Backshell with Self-Locking Rotatable Coupling and Strain Relief

A

CONNECTOR DESIGNATOR:	
<b>A</b>	MIL-DTL-5015, -26482 Series II, and -83723 Series I and III
<b>F</b>	MIL-DTL-38999 Series I, II
<b>L</b>	MIL-DTL-38999 Series 1.5 (JN1003)
<b>H</b>	MIL-DTL-38999 Series III and IV
<b>G</b>	MIL-DTL-28840
<b>U</b>	DG123 and DG123A
<b>SELF-LOCKING</b>	
<b>ROTATABLE COUPLING</b>	
<b>STANDARD PROFILE</b>	



**TABLE II: CONNECTOR SHELL SIZE**

Shell Size For		Connector Designator									
A	F/L	H	G	U	±.06 (1.5)	±.09 (2.3)	±.09 (2.3)	±.09 (2.3)	G	Max Entry	Dash No.**
08	08	09	-	-	.69 (17.5)	.88 (22.4)	1.06 (26.9)	1.06 (26.9)	10	10	
10	10	11	-	08	.75 (19.1)	1.00 (25.4)	1.13 (28.7)	1.13 (28.7)	12	12	
12	12	13	11	10	.81 (20.6)	1.13 (28.7)	1.19 (30.2)	1.19 (30.2)	14	14	
14	14	15	13	12	.88 (22.4)	1.31 (33.3)	1.25 (31.8)	1.25 (31.8)	16	16	
16	16	17	15	14	.94 (23.9)	1.38 (35.1)	1.31 (33.3)	1.31 (33.3)	20	20	
18	18	19	17	16	.97 (24.6)	1.44 (36.6)	1.34 (34.0)	1.34 (34.0)	20	20	
20	20	21	19	18	1.06 (26.9)	1.63 (41.4)	1.44 (36.6)	1.44 (36.6)	22	22	
22	22	23	-	20	1.13 (28.7)	1.75 (44.5)	1.50 (38.1)	1.50 (38.1)	24	24	
24	24	25	23	22	1.19 (30.2)	1.88 (47.8)	1.56 (39.6)	1.56 (39.6)	28	28	
28	-	-	25	24	1.34 (34.0)	2.13 (54.1)	1.66 (42.2)	1.66 (42.2)	32	32	

**TABLE III: FINISH**

Symbol	Finish Description
XM	2000 Hour Corrosion Resistant Electroless Nickel
XMT	2000 Hour Corrosion Resistant Ni-PTFE, Nickel-Fluorocarbon Polymer. 1000 Hour Grey™
XW	2000 Hour Corrosion Resistant Cadmium/Olive Drab over Electroless Nickel

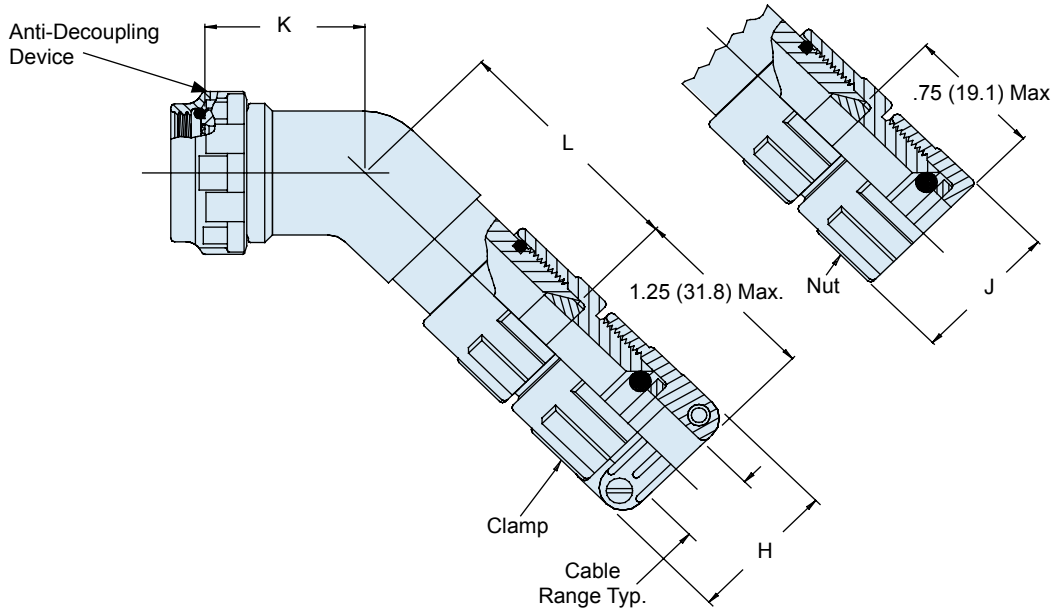
390-052

**Composite Cone and Ring Style**  
EMI/RFI Environmental Shield Termination Backshell  
with Self-Locking Rotatable Coupling and Strain Relief



Composite Backshells

**A**



**TABLE IV: CABLE ENTRY (CONT.)**

Entry Code	H		J		Cable Range				Entry Code	Clamp Saddle Closed	
	±.06	(1.5)	±.06	(1.5)	Minimum	Maximum					
10	.94	(23.9)	.80	(20.3)	.13	(3.3)	.25	(6.4)	10	.20	(5.1)
12	1.17	(29.7)	.93	(23.6)	.25	(6.4)	.38	(9.7)	12	.29	(7.4)
14	1.28	(32.5)	1.06	(26.9)	.31	(7.9)	.44	(11.2)	14	.40	(10.2)
16	1.41	(35.8)	1.22	(31.0)	.50	(12.7)	.63	(15.9)	16	.48	(12.2)
18	1.50	(38.1)	1.24	(31.5)	.56	(14.2)	.69	(17.5)	18	.55	(14.0)
20	1.56	(39.6)	1.37	(34.8)	.63	(16.0)	.75	(19.1)	20	.64	(16.0)
22	1.69	(42.9)	1.49	(37.8)	.75	(19.1)	.88	(22.2)	22	.72	(18.3)
24	1.81	(46.0)	1.62	(41.1)	.88	(22.4)	1.00	(25.4)	24	.79	(20.1)
28	1.91	(48.5)	1.68	(42.7)	1.00	(25.4)	1.13	(28.6)	28	.89	(22.0)
32	2.02	(51.3)	1.82	(46.2)	1.13	(28.6)	1.25	(31.8)	32	.96	(24.0)

**TABLE II: CONNECTOR SHELL SIZE (CONT.)**

Shell Size For Connector Designator						
A & F/L	H	K		L		Max Entry Dash No. *
		±.06	(1.5)	±.06	(1.5)	
08	09	.72	(18.3)	.88	(22.4)	10
10	11	.75	(19.1)	.94	(23.9)	12
12	13	.75	(19.1)	1.00	(25.4)	14
14	15	.76	(19.3)	1.03	(26.2)	16
16	17	.78	(19.8)	1.06	(26.9)	20
18	19	.79	(20.1)	1.07	(27.2)	20
20	21	.82	(20.8)	1.09	(27.7)	22
22	23	.86	(21.8)	1.14	(29.0)	24
24	25	.92	(23.4)	1.17	(29.7)	28

**NOTES**

1. Coupling nut supplied unplated.
2. Metric dimensions (mm) are in parenthesis and are for reference only.
3. Consult factory for additional entry sizes available.
4. See Table I in Intro for front-end dimensional details.

CONNECTOR DESIGNATOR:

<b>F</b>	MIL-DTL-38999 Series I, II
<b>H</b>	MIL-DTL-38999 Series III and IV
<b>ROTATABLE COUPLING</b>	
<b>STANDARD PROFILE</b>	

A

Product Series  
440 - Banding Strain Relief

Angle and Profile  
A - 90° Clamp  
B - 45° Clamp  
S - Straight  
W - 90° Split Clamp

Coupling Nut  
Finish Symbol  
(See Table III)  
XM - 90° Elbow

Supplied with  
600-083 Band  
(Omit if Not Required)

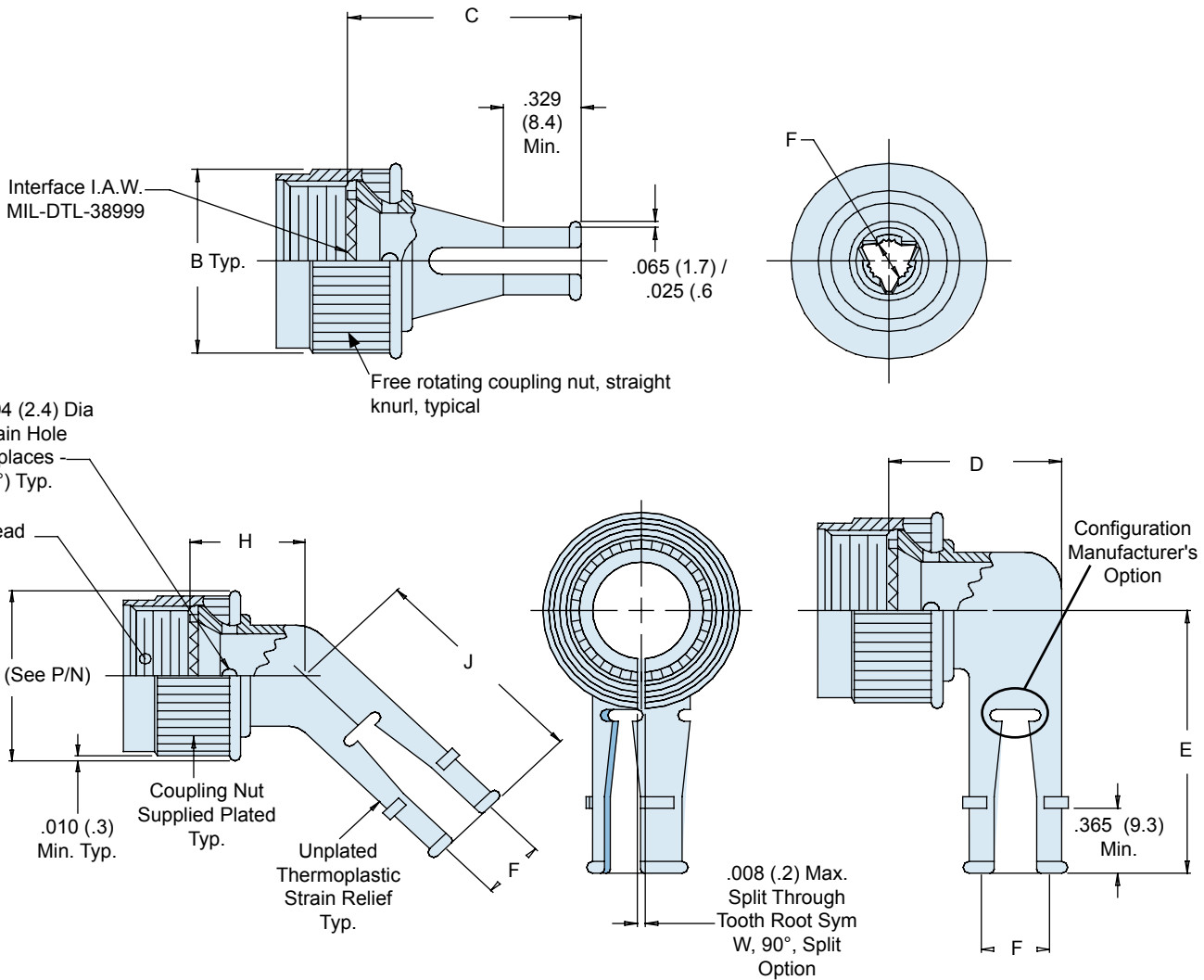
**440 F S 087 XM 20 B L**

Connector Designator  
F and H

Basic Part Number  
087

Connector Shell Size  
(See Table II)  
XM 20

Add Letter "L" for Coupling Nut Less G Diameter  
Omit Letter "L" for Coupling Nut With G Diameter



440-087  
Ultra Lightweight Banding Strain Relief  
with Rotatable Coupling



TABLE II: CONNECTOR SHELL SIZE ORDER NUMBER

Shell Size For Connector Designator		B	C	D		E
H	F	Max	Max	+03 -06	(.8) (1.5)	Max
09	08	.562 (14.3)	1.22 (31.0)	.66	(16.8)	1.02 (25.9)
11	10	.688 (17.5)	1.22 (31.0)	.69	(17.5)	1.07 (27.2)
13	12	.817 (20.8)	1.22 (31.0)	.75	(19.1)	1.13 (28.7)
15	14	.930 (23.6)	1.22 (31.0)	.86	(21.8)	1.33 (33.8)
17	16	1.062 (27.0)	1.22 (31.0)	.94	(23.9)	1.40 (35.6)
19	18	1.188 (30.2)	1.22 (31.0)	1.00	(25.4)	1.46 (37.1)
21	20	1.312 (33.3)	1.30 (33.0)	1.07	(27.2)	1.61 (40.9)
23	22	1.438 (36.5)	1.30 (33.0)	1.15	(29.2)	1.66 (42.2)
25	24	1.562 (39.7)	1.30 (33.0)	1.21	(30.7)	1.72 (43.7)

TABLE II: CONNECTOR SHELL SIZE ORDER NUMBER (CONT.)

Shell Size For Connector Designator		F Cable Dia		G	H	J
H	F	Minimum	Maximum	Max	Max	Max
09	08	.094 (2.4)	.203 (5.2)	.65 (16.5)	.470 (11.9)	1.02 (25.9)
11	10	.141 (3.6)	.250 (6.4)	.76 (19.3)	.482 (12.2)	1.07 (27.2)
13	12	.172 (4.4)	.323 (8.2)	.89 (22.6)	.494 (12.5)	1.13 (28.7)
15	14	.203 (5.2)	.422 (10.7)	1.04 (26.4)	.530 (13.5)	1.33 (33.8)
17	16	.234 (5.9)	.500 (12.7)	1.16 (29.5)	.557 (14.1)	1.40 (35.6)
19	18	.265 (6.7)	.562 (14.3)	1.28 (32.5)	.576 (14.6)	1.46 (37.1)
21	20	.297 (7.5)	.625 (15.9)	1.40 (35.6)	.600 (15.2)	1.61 (40.9)
23	22	.328 (8.3)	.703 (17.9)	1.51 (38.4)	.627 (15.9)	1.66 (42.2)
25	24	.359 (9.1)	.765 (19.4)	1.63 (41.4)	.653 (16.6)	1.72 (43.7)

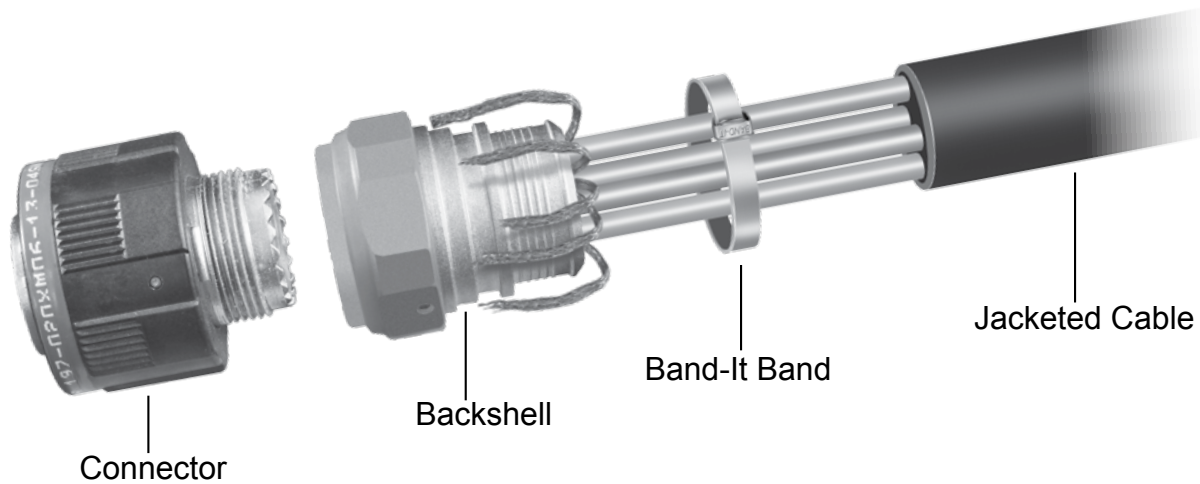
NOTES

- Metric dimensions (mm) are in parenthesis and are for reference only.
- See Table I in Intro for front-end dimensional details.

TABLE III: FINISH

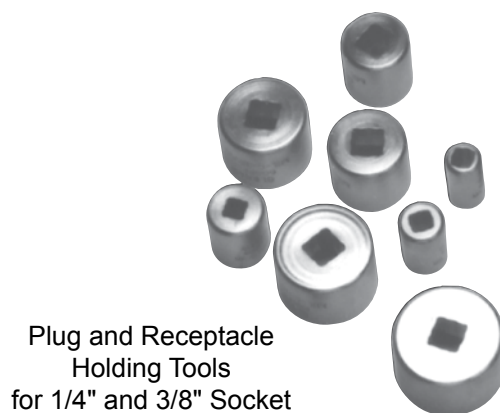
Symbol	Material / Finish Description
XM	Coupling Nut: Aluminum / Electroless Nickel Body: Thermoplastic / Black Color
XMT	Coupling Nut: Aluminum / 1000 Hour Grey™ Body: Thermoplastic / Black Color
XW	Coupling Nut: Aluminum / Cad O.D. over Electroless Nickel Body: Thermoplastic / Black Color

A



1. Temporarily assemble backshell to connector.
2. If cable is jacketed, insert cable into backshell and bottom against connector. Using the end of the backshell as a guide, mark the location of solder sleeves and/or pigtail breakouts on the cable.
3. Remove backshell from connector and stage it up the cable for installation after wire termination is complete.
4. Trim cable jacket at marked location from step 2 above and pull out pigtails and/or apply solder sleeves. Terminate contacts to wires in accordance with established practices.
5. Evenly distribute shields around backshell banding platform.
6. Secure shields to banding platform via Band-It band. See banding assembly procedure for details.
7. Apply silicone tape to band area (if applicable).
8. Apply Glenair 770-001 heat moldable shrink boot to terminated banding area for added environmental protection and strain relief. See heat moldable product user instructions for details.

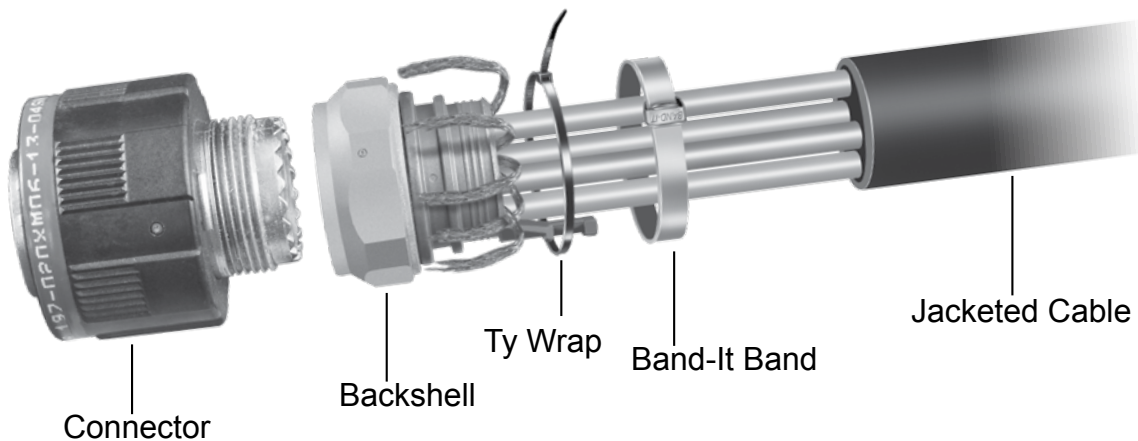
COMPOSITE COUPLING TORQUE VALUES	
Shell Size Reference	Composite Torque (Inch-Pounds)
08/09	35
10/11	35
12/13	40
14/15	40
16/17	40
18/19	40
20/21	80
22/23	80
24/25	80
28	120
32	120
36	120



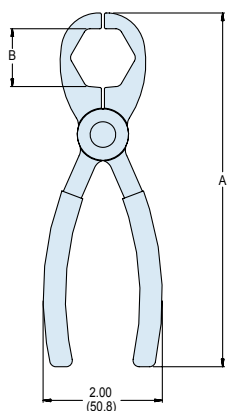
600-161  
Hand Held Digital Torque Wrench



# Banding Backshell with Qwik-Ty Assembly Instructions for 440-143 and 447-327



1. Temporarily assemble backshell to connector.
2. If cable is jacketed, insert cable into backshell and bottom against connector. Using the end of the backshell as a guide, mark the location of solder sleeves and/or pigtail breakouts on the cable.
3. Remove backshell from connector and stage it up the cable for installation after wire termination is complete.
4. Trim cable jacket at marked location from step 2 above and pull out pigtails and/or apply solder sleeves. Terminate contacts to wires in accordance with established practices.
5. Evenly distribute shields around backshell banding platform.
6. Secure shields to banding platform via Band-It band. See banding procedure for details.
7. Apply silicone tape to band area (if applicable).
8. Apply lacing cord or ty wrap around bundle—securing it to Qwik Ty arm.
9. Apply Glenair 770-001 heat moldable shrink boot to terminated banding area for added environmental protection and strain relief. See heat moldable product user instructions for details.



600-157  
Stainless Steel Composite  
Hex Coupling Wrench

600-052 and -057  
Standard and Micro  
Band-It® Bands



600-058  
Band-It®  
Hand Banding Tool



# 440-143

## Composite Ultra Low Profile EMI/RFI Micro-Banding Backshell with Qwik-Ty, Shrink Boot Porch and Self-Locking Rotatable Coupling

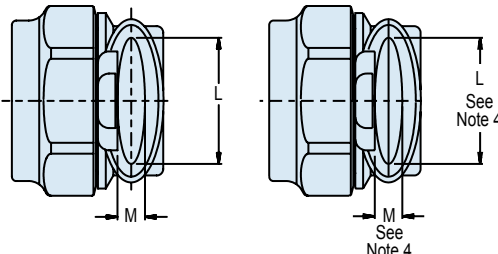
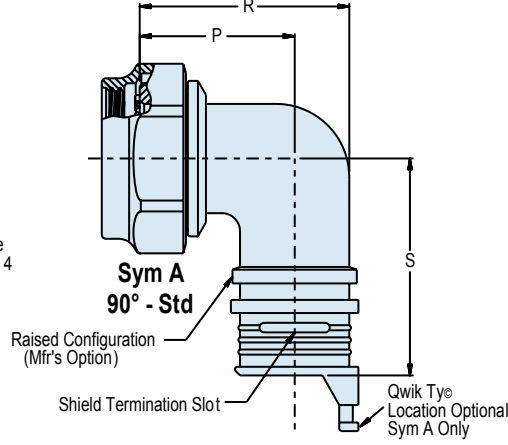
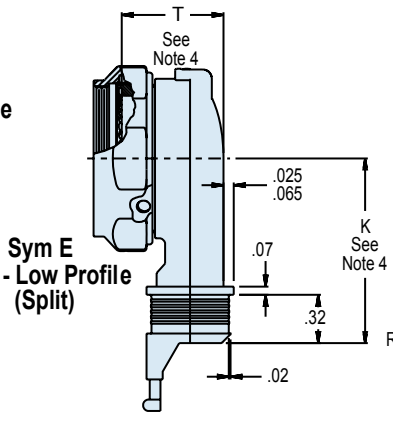
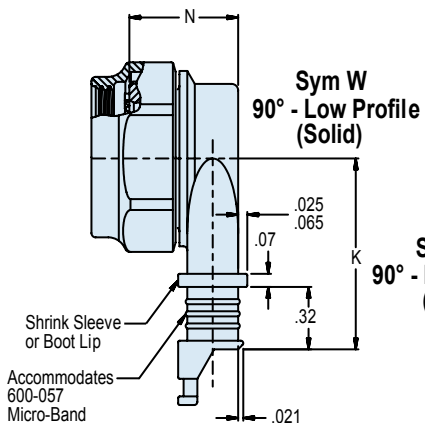
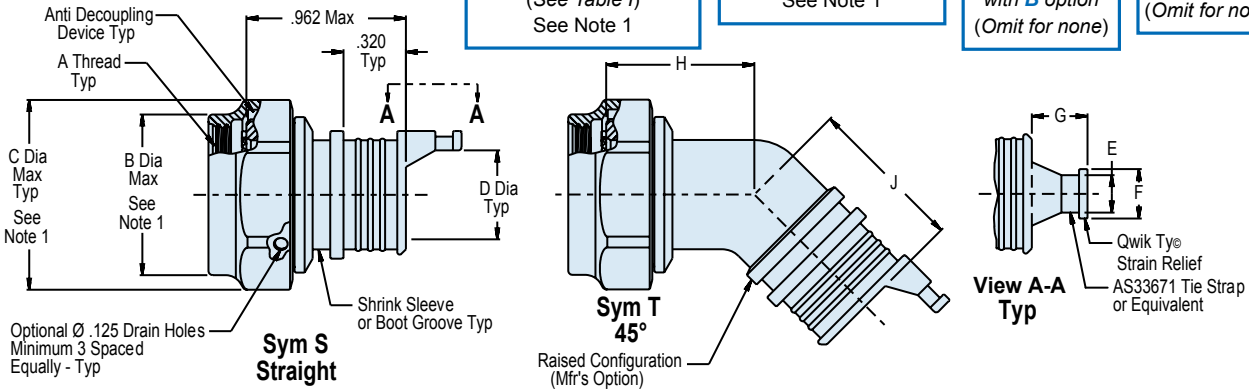
**A**

CONNECTOR DESIGNATOR:	
<b>F</b>	MIL-DTL-38999 Series I, II
<b>H</b>	MIL-DTL-38999 Series III and IV
<b>SELF-LOCKING</b>	
<b>ROTATABLE COUPLING</b>	
<b>ULTRA LOW PROFILE</b>	

<b>Angle and Profile</b> <i>S</i> - Straight <i>A</i> - 90° Low Profile, Std <i>T</i> - 45° Elbow <i>E</i> - 90° Low Profile, Split <i>W</i> - 90° Low Profile, Solid	<b>Cable Entry</b> (See Table II) Omit for <i>E</i> and <i>W</i> Option Only	<b>Drain Hole Option</b> (Omit "D" if not required)
<b>Product Series</b> 440 - EMI/RFI Non-Environmental Micro-Banding Backshells	<b>Basic Part Number</b>	<b>Shrink Boot Option</b> Shrink boot supplied with <i>T</i> option O-Ring will not be supplied with Connector Designator A (Omit for none)
<b>Finish Symbol</b> (See Table III)		

**440 H S 143 XM 15 09 D B T S**

<b>Connector Designator</b> <i>A, F or H</i> (See Table I) See Note 1	<b>Connector Shell Size</b> (See Table I) See Note 1	<b>Band Option</b> Band supplied with <i>B</i> option (Omit for none)	<b>Shield Termination Slot</b> (Omit for none)
--	--	--	---





**440-143**  
**Composite Ultra Low Profile EMI/RFI**  
**Micro-Banding Backshell with Qwik-Ty, Shrink Boot Porch**  
**and Self-Locking Rotatable Coupling**



**TABLE I: SHELL SIZE**

Shell Size		Entry Code Available for Straight, 45° and 90° Std Configuration	K ± .03	L	M	N Max	P ±.09	R ±.09	S Max	T Max
A & F	H									
08	09	04	1.042 (26.5)	.304 (7.7)	.160 (4.1)	.630 (16.0)	.690 (17.5)	.880 (22.4)	1.360 (34.5)	.810 (20.6)
10	11	05	1.107 (28.1)	.432 (11.0)	.174 (4.4)	.660 (16.8)	.750 (19.1)	1.000 (24.5)	1.420 (36.1)	.810 (20.6)
12	13	07	1.174 (29.8)	.546 (13.9)	.195 (5.0)	.720 (18.3)	.810 (20.6)	1.130 (28.7)	1.480 (37.6)	.820 (20.8)
14	15	09	1.241 (31.5)	.670 (17.0)	.315 (8.0)	.830 (21.1)	.880 (22.4)	1.310 (33.3)	1.550 (39.4)	.880 (22.4)
16	17	05 and 11	1.305 (33.1)	.796 (20.2)	.385 (9.8)	.910 (23.1)	.940 (23.9)	1.380 (35.1)	1.610 (40.9)	.930 (23.6)
18	19	07 and 13	1.371 (34.8)	.902 (22.9)	.445 (11.3)	.930 (23.6)	.970 (24.6)	1.440 (36.6)	1.640 (41.7)	.990 (25.1)
20	21	09 and 15	1.438 (36.5)	1.027 (26.1)	.525 (13.3)	1.040 (26.4)	1.060 (26.9)	1.630 (41.4)	1.730 (43.9)	1.060 (26.9)
22	23	11 and 16	1.505 (38.2)	1.152 (29.3)	.595 (15.1)	1.120 (28.4)	1.130 (28.7)	1.750 (44.5)	1.800 (45.7)	1.130 (28.7)
24	25	07, 13 and 17	1.572 (39.9)	1.276 (32.4)	.655 (16.6)	1.180 (30.0)	1.190 (30.2)	1.880 (47.8)	1.860 (47.2)	1.050 (26.7)
24*	25		1.850 (47.0)	1.460 (37.1)	.450 (11.4)	1.020 (26.0)				1.050 (26.7)

\*See Note 4

**TABLE II: CABLE ENTRY**

Entry Code	D ± .030	E Ref	F Ref	G Ref	H ± .060	J ± .090
04	.250 (6.4)	.187 (4.7)	.312 (7.9)	.512 (13.0)	.720 (18.3)	.870 (22.1)
05	.310 (7.9)	.187 (4.7)	.312 (7.9)	.512 (13.0)	.750 (19.1)	.930 (23.6)
07	.440 (11.2)	.187 (4.7)	.312 (7.9)	.512 (13.0)	.750 (19.1)	1.00 (25.4)
09	.560 (14.2)	.219 (5.6)	.375 (9.5)	.630 (16.0)	.760 (19.3)	1.03 (26.2)
11	.680 (17.3)	.219 (5.6)	.375 (9.5)	.630 (16.0)	.780 (19.8)	1.05 (26.7)
13	.810 (20.6)	.219 (5.6)	.375 (9.5)	.630 (16.0)	.790 (20.1)	1.06 (26.9)
15	.940 (23.9)	.219 (5.6)	.375 (9.5)	.630 (16.0)	.820 (20.8)	1.09 (27.7)
16	1.000 (25.4)	.219 (5.6)	.375 (9.5)	.630 (16.0)	.860 (21.8)	1.13 (28.7)
17	1.160 (29.5)	.250 (6.4)	.437 (11.1)	.630 (16.0)	.890 (22.6)	1.16 (29.5)

**TABLE III: FINISH**

Symbol	Finish Description
<b>XM</b>	2000 Hour Corrosion Resistant Electroless Nickel
<b>XMT</b>	2000 Hour Corrosion Resistant Ni-PTFE, Nickel-Fluorocarbon Polymer. <i>1000 Hour Grey™</i>
<b>XW</b>	2000 Hour Corrosion Resistant Cadmium/Olive Drab over Electroless Nickel

**NOTES**

1. 770-001S\*\*-0 shrink boot supplied with T option. See shrink boot product page for more details.
2. Coupling nut supplied unplated.
3. See Table I in Intro for front-end dimensional details.
4. For Sym "E" low profile split shell sizes 24 and 25 dimensions, use indicator row in Table I.



# 440-144

## Composite Ultra Low Profile EMI/RFI Micro-Banding Backshell with Shrink Boot Porch and Self-Locking Rotatable Coupling

**A**

CONNECTOR DESIGNATOR:	
<b>F</b>	MIL-DTL-38999 Series I, II
<b>H</b>	MIL-DTL-38999 Series III and IV
<b>SELF-LOCKING</b>	
<b>ROTATABLE COUPLING</b>	
<b>ULTRA LOW PROFILE</b>	

**Angle and Profile**  
*S* - Straight      *A* - 90° Low Profile, Std  
*T* - 45° Elbow      *E* - 90° Low Profile, Split  
*W* - 90° Low Profile, Solid

**Cable Entry**  
 (See Table II)  
 Omit for *E* and *W* Option Only

**Drain Hole Option**  
 (Omit "D" if not required)

**Shrink Boot Option**  
 Shrink boot supplied with *T* option  
 O-Ring will not be supplied with Connector Designator A  
 (Omit for none)

**Product Series**  
 440 - EMI/RFI Non-Environmental Micro-Banding Backshells

**Basic Part Number**

**Finish Symbol**  
 (See Table III)

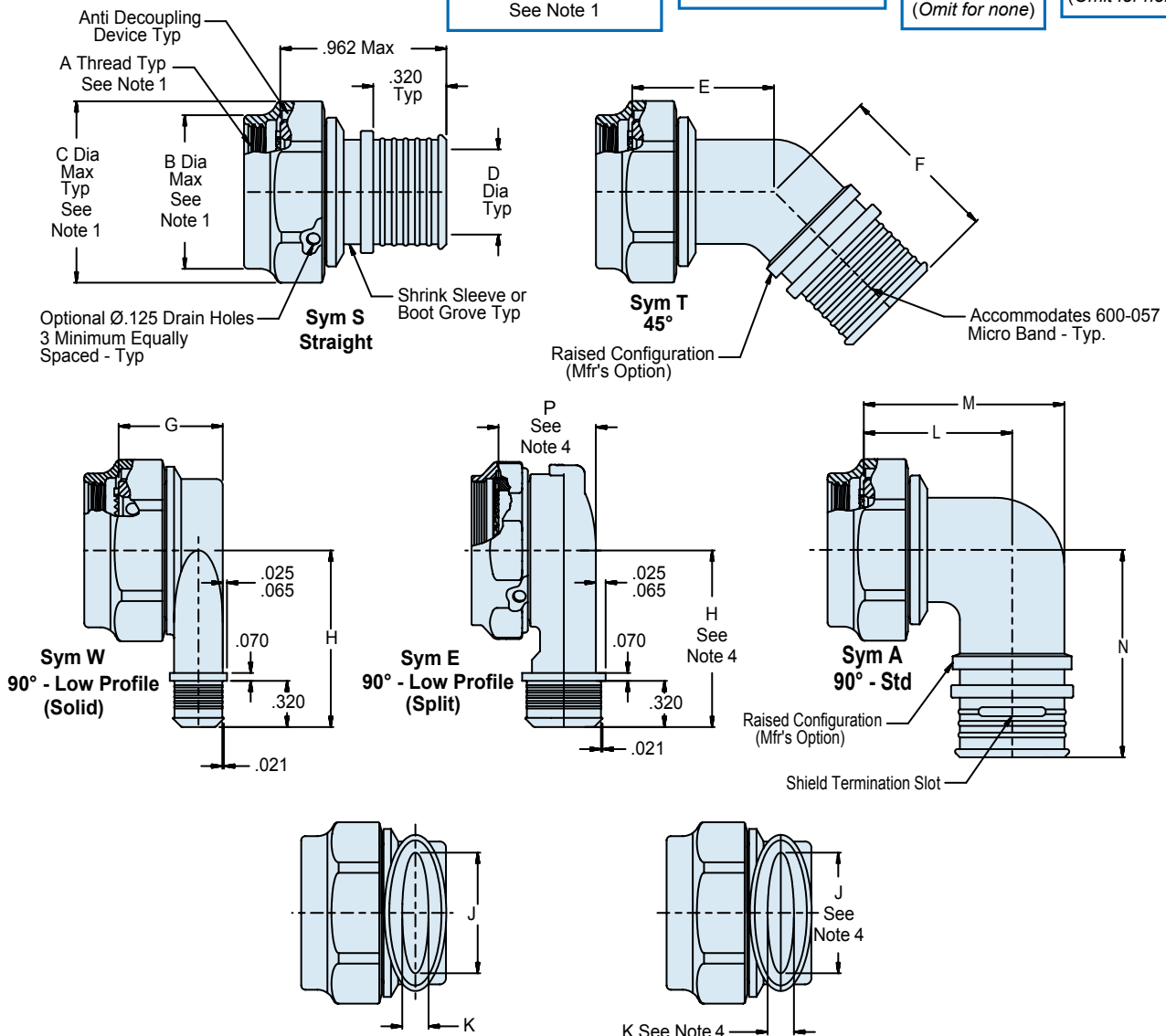
**440 H S 144 XM 15 09 D B T S**

**Connector Designator**  
*A, F or H*  
 (See Table I)  
 See Note 1

**Connector Shell Size**  
 (See Table I)  
 See Note 1

**Band Option**  
*B* - 600-057  
*K* - 600-057-1  
 (Omit for none)

**Shield Termination Slot**  
 (Omit for none)



**440-144**  
**Composite Ultra Low Profile EMI/RFI**  
**Micro-Banding Backshell with Shrink Boot Porch**  
**and Self-Locking Rotatable Coupling**



**TABLE I: SHELL SIZE**

Shell Size		Entry Code Available for Straight, 45° and 90° Std Configuration	G Max	H ± .03	J	K	L. ± .09	M ±.09	N Max	P Max
A & F	H									
08	09	04	.630 (16.0)	1.042 (26.5)	.304 (7.7)	.160 (4.1)	.690 (17.5)	.880 (22.4)	1.360 (34.5)	.810 (20.6)
10	11	05	.660 (16.8)	1.107 (28.1)	.432 (11.0)	.174 (4.4)	.750 (19.1)	1.000 (24.5)	1.420 (36.1)	.810 (20.6)
12	13	07	.720 (18.3)	1.174 (29.8)	.546 (13.9)	.195 (5.0)	.810 (20.6)	1.130 (28.7)	1.480 (37.6)	.820 (20.8)
14	15	09	.830 (21.1)	1.241 (31.5)	.670 (17.0)	.315 (8.0)	.880 (22.4)	1.310 (33.3)	1.550 (39.4)	.880 (22.4)
16	17	05 and 11	.910 (23.1)	1.305 (33.1)	.796 (20.2)	.385 (9.8)	.940 (23.9)	1.380 (35.1)	1.610 (40.9)	.930 (23.6)
18	19	07 and 13	.930 (23.6)	1.371 (34.8)	.902 (22.9)	.445 (11.3)	.970 (24.6)	1.440 (36.6)	1.640 (41.7)	.990 (25.1)
20	21	09 and 15	1.040 (26.4)	1.438 (36.5)	1.027 (26.1)	.525 (13.3)	1.060 (26.9)	1.630 (41.4)	1.730 (43.9)	1.060 (26.9)
22	23	11 and 16	1.120 (28.4)	1.505 (38.2)	1.152 (29.3)	.595 (15.1)	1.130 (28.7)	1.750 (44.5)	1.800 (45.7)	1.130 (28.7)
24	25	07, 13 and 17	1.180 (30.0)	1.572 (39.9)	1.276 (32.4)	.655 (16.6)	1.190 (30.2)	1.880 (47.8)	1.860 (47.2)	1.050 (26.7)
24*	25		1.020 (26.0)	1.850 (47.0)	1.460 (37.1)	.450 (11.4)				1.050 (26.7)

\*See Note 2

**TABLE II: CABLE ENTRY**

Entry Code	D ± .030	E ± .060	F ± .090
04	.250 (6.4)	.720 (18.3)	.870 (22.1)
05	.310 (7.9)	.750 (19.1)	.930 (23.6)
07	.440 (11.2)	.750 (19.1)	1.000 (25.4)
09	.560 (14.2)	.760 (19.3)	1.030 (26.2)
11	.680 (17.3)	.780 (19.8)	1.050 (26.7)
13	.810 (20.6)	.790 (20.1)	1.060 (26.9)
15	.940 (23.9)	.820 (20.8)	1.090 (27.7)
16	1.000 (25.4)	.860 (21.8)	1.130 (28.7)
17	1.160 (29.5)	.890 (22.6)	1.160 (29.5)

**TABLE III: FINISH**

Symbol	Finish Description
XM	2000 Hour Corrosion Resistant Electroless Nickel
XMT	2000 Hour Corrosion Resistant Ni-PTFE, Nickel-Fluorocarbon Polymer. <i>1000 Hour Grey™</i>
XW	2000 Hour Corrosion Resistant Cadmium/Olive Drab over Electroless Nickel

**NOTES**

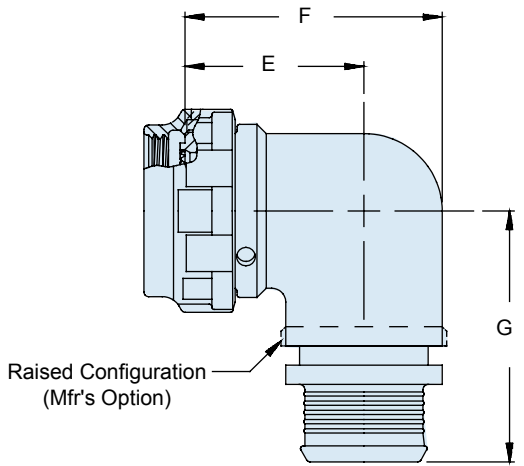
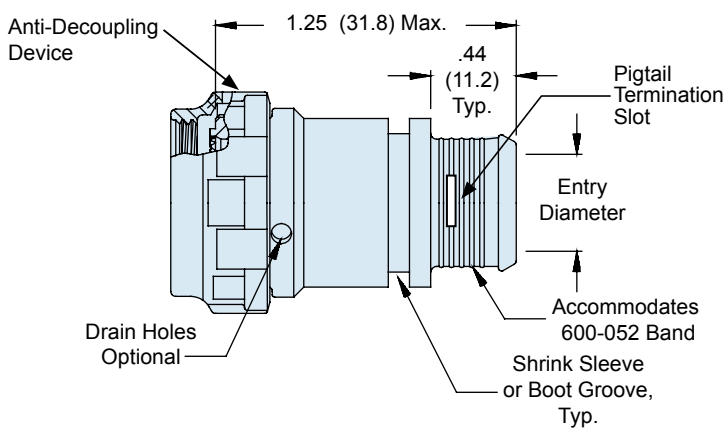
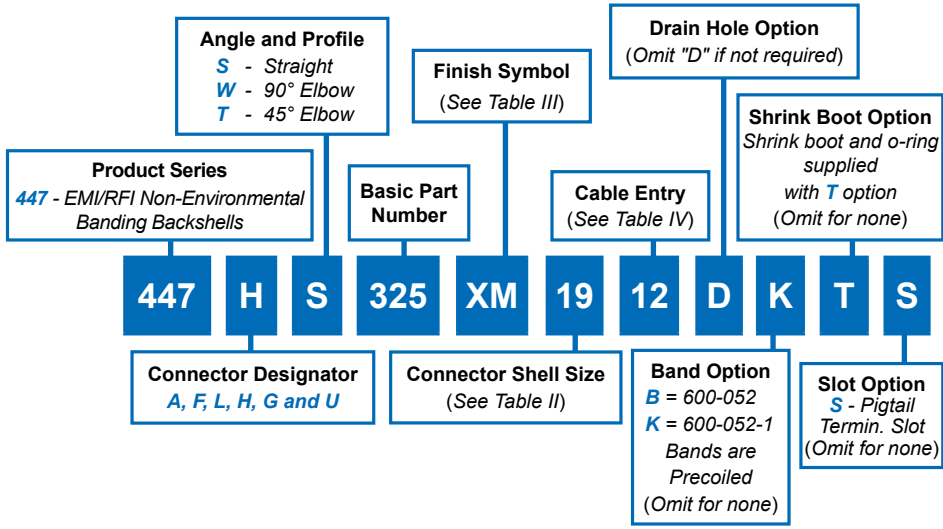
- 770-001S\*\*-0 shrink boot supplied with T option. See shrink boot product page for more details.
- For Sym "E" low profile split shell sizes 24 and 25 dimensions, use indicator row in Table I.
- Coupling nut supplied unplated.
- See Table I in Intro for front-end dimensional details.



# 447-325 Composite Standard Profile EMI/RFI Banding Backshell with Shrink Boot Porch and Self-Locking Rotatable Coupling

**A**

CONNECTOR DESIGNATOR:	
<b>A</b>	MIL-DTL-5015, -26482 Series II, and -83723 Series I and III
<b>F</b>	MIL-DTL-38999 Series I, II
<b>L</b>	MIL-DTL-38999 Series 1.5 (JN1003)
<b>H</b>	MIL-DTL-38999 Series III and IV
<b>G</b>	MIL-DTL-28840
<b>U</b>	DG123 and DG123A
<b>SELF-LOCKING</b>	
<b>ROTATABLE COUPLING</b>	
<b>STANDARD PROFILE</b>	



**TABLE II: CONNECTOR SHELL SIZE (90°)**

Shell Size For Connector Designator*					E	F	G	Max Entry Dash No. (Table IV)**
A	F/L	H	G	U	± .06 (1.5)	± .09 (2.3)	± .09 (2.3)	
08	08	09	-	-	.69 (17.5)	.88 (22.4)	1.19 (30.2)	04
10	10	11	-	08	.75 (19.1)	1.00 (25.4)	1.25 (31.8)	06
12	12	13	11	10	.81 (20.6)	1.13 (28.7)	1.31 (33.3)	08
14	14	15	13	12	.88 (22.4)	1.31 (33.3)	1.38 (35.1)	10
16	16	17	15	14	.94 (23.9)	1.38 (35.1)	1.44 (36.6)	12
18	18	19	17	16	.97 (24.6)	1.44 (36.6)	1.47 (37.3)	13
20	20	21	19	18	1.06 (26.9)	1.63 (41.4)	1.56 (39.6)	15
22	22	23	-	20	1.13 (28.7)	1.75 (44.5)	1.63 (41.4)	17
24	24	25	23	22	1.19 (30.2)	1.88 (47.8)	1.69 (42.9)	19
28	-	-	25	24	1.34 (34.0)	2.13 (54.1)	1.78 (45.2)	22

\*\*Consult factory for additional entry sizes available.

447-325

# Composite Standard Profile EMI/RFI Banding Backshell with Shrink Boot Porch and Self-Locking Rotatable Coupling

 Composite  
Backshells

A

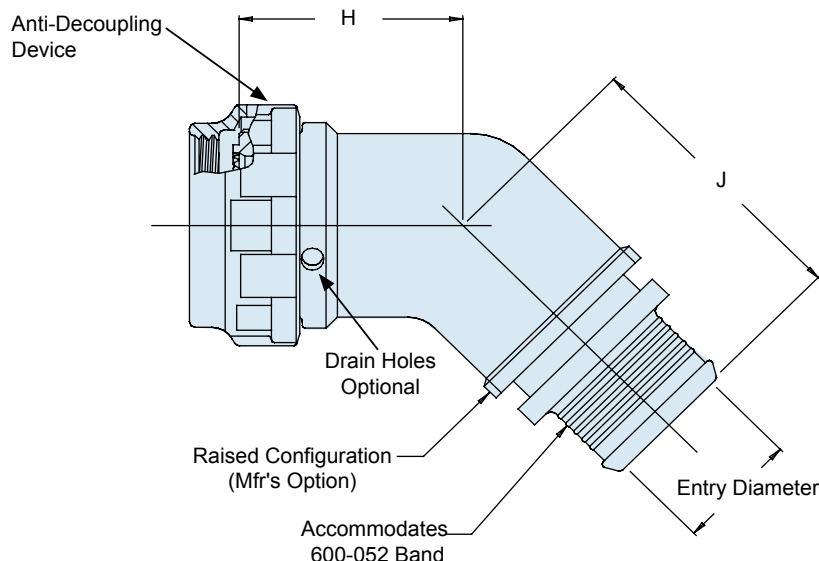


TABLE IV: CABLE ENTRY

Entry Code	Entry Dia.		Dash No.	Entry Dia.	
	±.03	(0.8)		±.03	(0.8)
03	.19	(4.8)	13	.81	(20.6)
04	.25	(6.4)	14	.88	(22.4)
05	.31	(7.9)	15	.94	(23.9)
06	.38	(9.7)	16	1.00	(25.4)
07	.44	(11.2)	17	1.06	(26.9)
08	.50	(12.7)	18	1.13	(28.7)
09	.56	(14.2)	19	1.19	(30.2)
10	.63	(16.0)	20	1.25	(31.8)
11	.69	(17.5)	22	1.38	(35.1)
12	.75	(19.1)			

TABLE III: FINISH

Symbol	Finish Description
XM	2000 Hour Corrosion Resistant Electroless Nickel
XMT	2000 Hour Corrosion Resistant Ni-PTFE, Nickel-Fluorocarbon Polymer. 1000 Hour Grey™
XW	2000 Hour Corrosion Resistant Cadmium/Olive Drab over Electroless Nickel

TABLE II: CONNECTOR SHELL SIZE (45°)

Shell Size For Connector Designator*						H	J	Max Entry Dash No.
A	F/L	H	G	U		±.06 (1.5)	±.09 (2.3)	(Table IV)
08	08	09	-	-		.72 (18.3)	1.00 (25.4)	04
10	10	11	-	08		.75 (19.1)	1.06 (26.9)	06
12	12	13	11	10		.75 (19.1)	1.13 (28.7)	08
14	14	15	13	12		.76 (19.3)	1.16 (29.5)	10
16	16	17	15	14		.78 (19.8)	1.18 (30.0)	12
18	18	19	17	16		.79 (20.1)	1.19 (30.2)	13
20	20	21	19	18		.82 (20.8)	1.22 (31.0)	15
22	22	23	-	20		.86 (21.8)	1.26 (32.0)	17
24	24	25	23	22		.89 (22.6)	1.29 (32.8)	19
28	-	-	25	24		.92 (23.4)	1.32 (33.5)	22

## NOTES

- 770-001S\*\*-0 shrink boot supplied with T option. See shrink boot product page for more details.
- O-Ring will not be supplied with Connector Designator A.
- Coupling nut supplied unplated.
- Consult factory for O-Ring to be supplied with part less shrink boot.
- Metric dimensions (mm) are in parenthesis and are for reference only.
- See Table I in Intro for front-end dimensional details.



# 447-326 Composite Standard Profile EMI/RFI Micro-Banding Backshell with Self-Locking Rotatable Coupling and Shrink Boot Porch

**A**

CONNECTOR DESIGNATOR:	
<b>A</b>	MIL-DTL-5015, -26482 Series II, and -83723 Series I and III
<b>F</b>	MIL-DTL-38999 Series I, II
<b>L</b>	MIL-DTL-38999 Series 1.5 (JN1003)
<b>H</b>	MIL-DTL-38999 Series III and IV
<b>G</b>	MIL-DTL-28840
<b>U</b>	DG123 and DG123A
<b>SELF-LOCKING</b>	
<b>ROTATABLE COUPLING</b>	
<b>STANDARD PROFILE</b>	

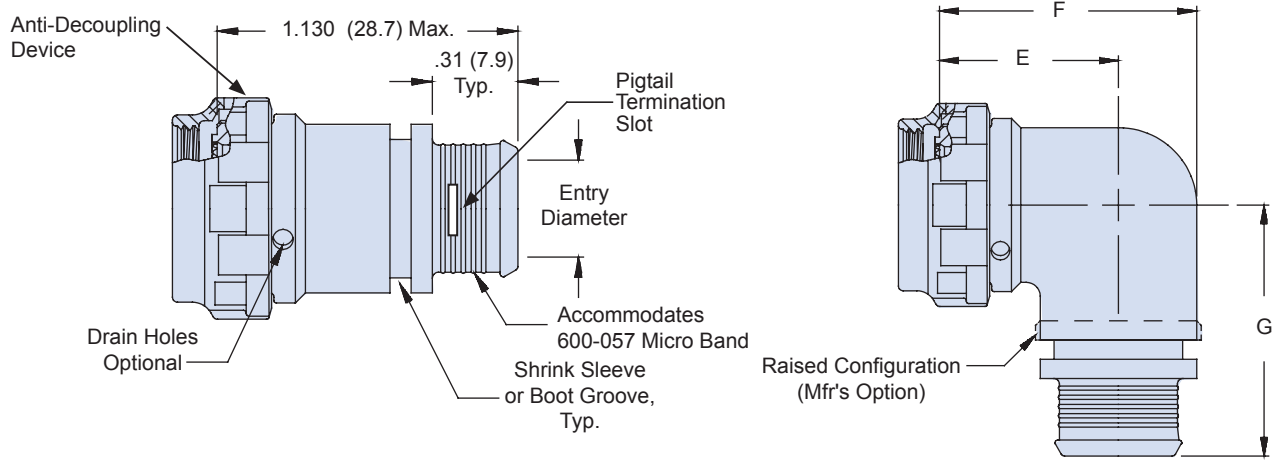
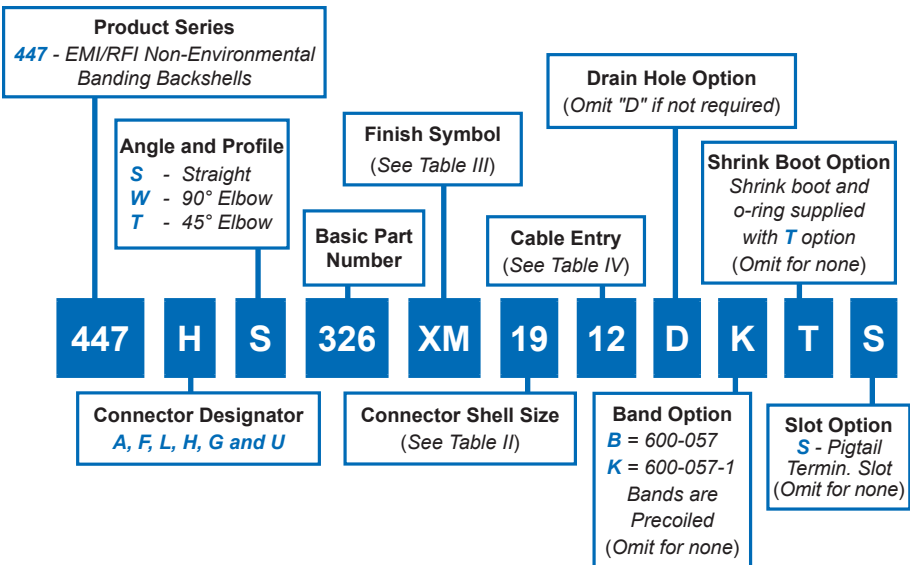
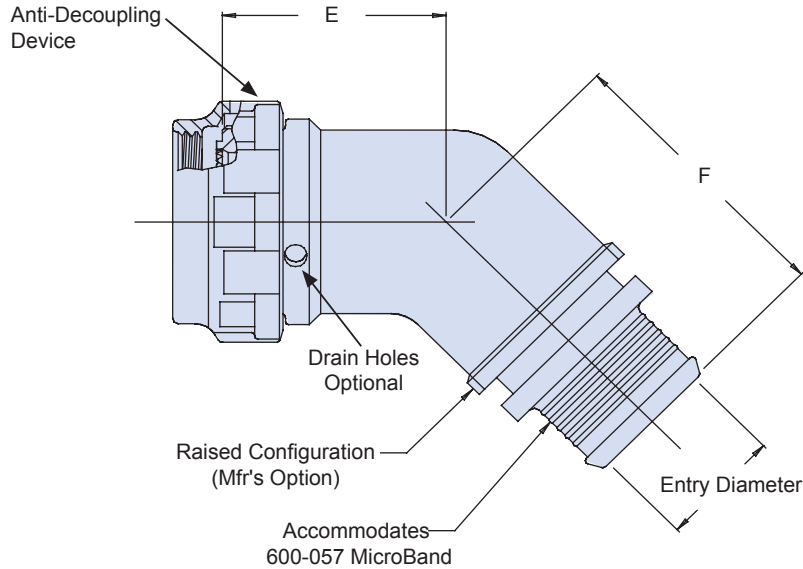


TABLE II: CONNECTOR SHELL SIZE									
Shell Size For Connector Designator*					E	F	G	Max Entry Dash No.**	
A	F/L	H	G	U	±.06 (1.5)	±.09 (2.3)	±.09 (2.3)		
08	08	09	-	-	.69 (17.5)	.88 (22.4)	1.06 (26.9)	04	
10	10	11	-	08	.75 (19.1)	1.00 (25.4)	1.13 (28.7)	06	
12	12	13	11	10	.81 (20.6)	1.13 (28.7)	1.19 (30.2)	08	
14	14	15	13	12	.88 (22.4)	1.31 (33.3)	1.25 (31.8)	10	
16	16	17	15	14	.94 (23.9)	1.38 (35.1)	1.31 (33.3)	12	
18	18	19	17	16	.97 (24.6)	1.44 (36.6)	1.38 (35.0)	13	
20	20	21	19	18	1.06 (26.9)	1.63 (41.4)	1.48 (36.8)	15	
22	22	23	-	20	1.13 (28.7)	1.75 (44.5)	1.54 (39.1)	17	
24	24	25	23	22	1.19 (30.2)	1.88 (47.8)	1.60 (40.6)	19	
28	-	-	25	24	1.34 (34.0)	2.13 (54.1)	1.70 (43.2)	22	

\*\*Consult factory for additional entry sizes available.  
See introduction for additional connector front-end details.

TABLE III: FINISH	
Symbol	Finish Description
XM	2000 Hour Corrosion Resistant Electroless Nickel
XMT	2000 Hour Corrosion Resistant Ni-PTFE, Nickel-Fluorocarbon Polymer. 1000 Hour Grey™
XW	2000 Hour Corrosion Resistant Cadmium/Olive Drab over Electroless Nickel

**447-326**  
**Composite Standard Profile EMI/RFI**  
**Micro-Banding Backshell**  
**with Self-Locking Rotatable Coupling and Shrink Boot Porch**



**TABLE II: CONNECTOR SHELL SIZE (CONT.)**

Shell Size For Connector Designator*					E	F	Max Entry Dash No. (Table 2)
A	F/L	H	G	U	±.06 (1.5)	±.09 (2.3)	
08	08	09	-	-	.72 (18.3)	.87 (22.1)	04
10	10	11	-	08	.75 (19.1)	.93 (23.6)	06
12	12	13	11	10	.75 (19.1)	1.00 (25.4)	08
14	14	15	13	12	.76 (19.3)	1.03 (26.2)	10
16	16	17	15	14	.78 (19.8)	1.05 (26.7)	12
18	18	19	17	16	.79 (20.1)	1.06 (26.9)	13
20	20	21	19	18	.82 (20.8)	1.09 (27.7)	15
22	22	23	-	20	.86 (21.8)	1.13 (28.7)	17
24	24	25	23	22	.89 (22.6)	1.16 (29.5)	19
28	-	-	25	24	.92 (23.4)	1.19 (30.2)	22

**TABLE IV: CABLE ENTRY**

Entry Code	Entry Dia. ±.03 (0.8)	Dash No.	Entry Dia. ±.03 (0.8)
02	.13 (3.3)	12	.75 (19.1)
03	.19 (4.8)	13	.81 (20.6)
04	.25 (6.4)	14	.88 (22.4)
05	.31 (7.9)	15	.94 (23.9)
06	.38 (9.7)	16	1.00 (25.4)
07	.44 (11.2)	17	1.06 (26.9)
08	.50 (12.7)	18	1.13 (28.7)
09	.56 (14.2)	19	1.19 (30.2)
10	.63 (16.0)	20	1.25 (31.8)
11	.69 (17.5)	22	1.38 (35.1)

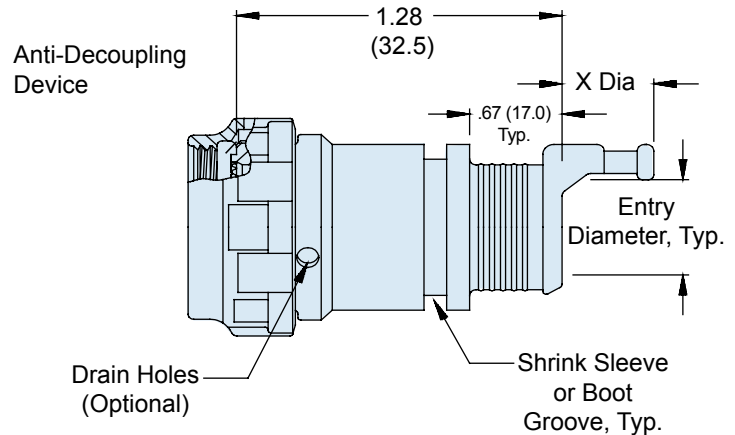
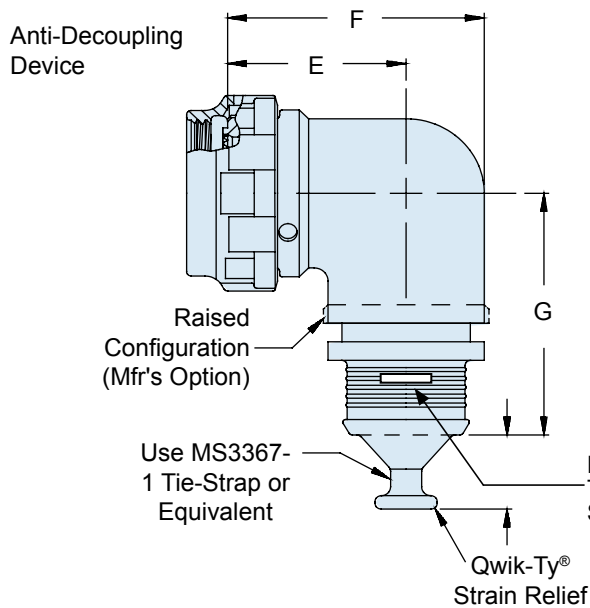
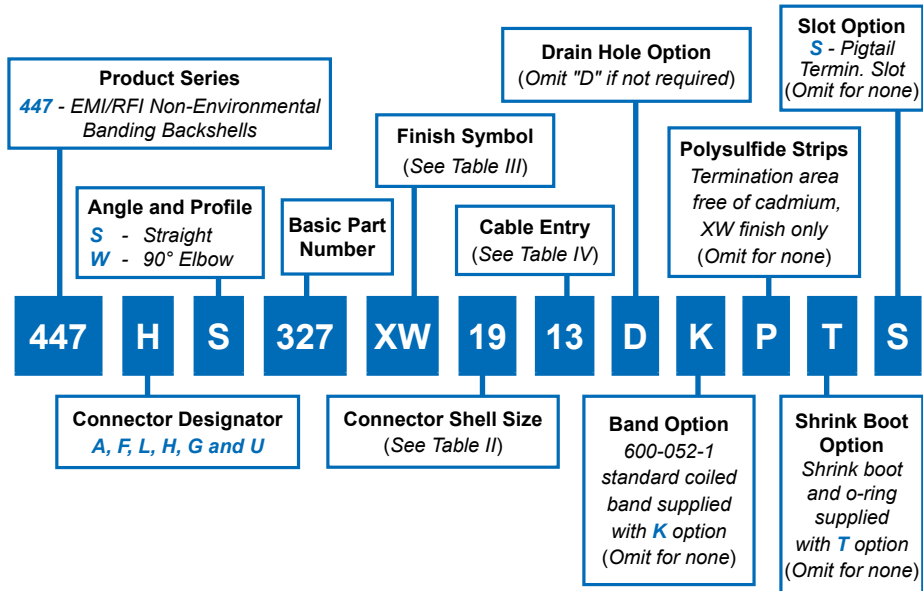
- NOTES**
- 770-001S\*\*-0 shrink boot supplied with T option. See shrink boot product page for more details.
  - O-Ring will not be supplied with Connector Designator A.
  - Metric dimensions (mm) are in parenthesis and are for reference only.
  - Coupling nut supplied unplated.
  - See Table I in Intro for front-end dimensional details.



# 447-327 Composite Standard Profile EMI/RFI Banding Backshell with Qwik-Ty® Strain Relief and Self-Locking Rotatable Coupling

**A**

CONNECTOR DESIGNATOR:	
<b>A</b>	MIL-DTL-5015, -26482 Series II, and -83723 Series I and III
<b>F</b>	MIL-DTL-38999 Series I, II
<b>L</b>	MIL-DTL-38999 Series 1.5 (JN1003)
<b>H</b>	MIL-DTL-38999 Series III and IV
<b>G</b>	MIL-DTL-28840
<b>U</b>	DG123 and DG123A
<b>SELF-LOCKING</b>	
<b>ROTATABLE COUPLING</b>	
<b>STANDARD PROFILE</b>	





**447-327**  
**Composite Standard Profile EMI/RFI**  
**Banding Backshell with Qwik-Ty® Strain Relief**  
**and Self-Locking Rotatable Coupling**



**TABLE II: CONNECTOR SHELL SIZE**

Shell Size For												
Connector Designator*					E		F		G		Max Entry	
A	F/L	H	G	U	±.06	(1.5)	±.09	(2.3)	±.09	(2.3)	Dash No**	
08	08	09	—	—	.69	(17.5)	.88	(22.4)	1.36	(34.5)	04	
10	10	11	—	08	.75	(19.1)	1.00	(25.4)	1.42	(36.1)	05	
12	12	13	11	10	.81	(20.6)	1.13	(28.7)	1.48	(37.6)	07	
14	14	15	13	12	.88	(22.4)	1.31	(33.3)	1.55	(39.4)	09	
16	16	17	15	14	.94	(23.9)	1.38	(35.1)	1.61	(40.9)	11	
18	18	19	17	16	.97	(24.6)	1.44	(36.6)	1.64	(41.7)	13	
20	20	21	19	18	1.06	(26.9)	1.63	(41.4)	1.73	(43.9)	15	
22	22	23	—	20	1.13	(28.7)	1.75	(44.5)	1.80	(45.7)	17	
24	24	25	23	22	1.19	(30.2)	1.88	(47.8)	1.86	(47.2)	20	

\*\*Consult factory for additional entry sizes available.

**TABLE III: FINISH**

Symbol	Finish Description
XM	2000 Hour Corrosion Resistant Electroless Nickel
XMT	2000 Hour Corrosion Resistant Ni-PTFE, Nickel-Fluorocarbon Polymer. <i>1000 Hour Grey™</i>
XW	2000 Hour Corrosion Resistant Cadmium/Olive Drab over Electroless Nickel

**TABLE IV: CABLE ENTRY**

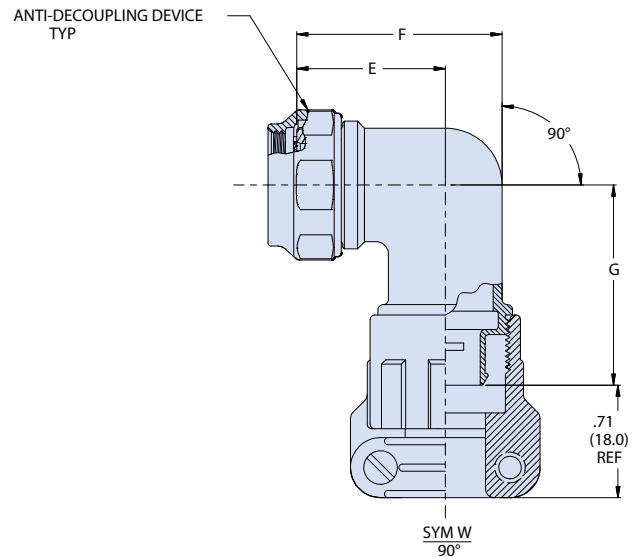
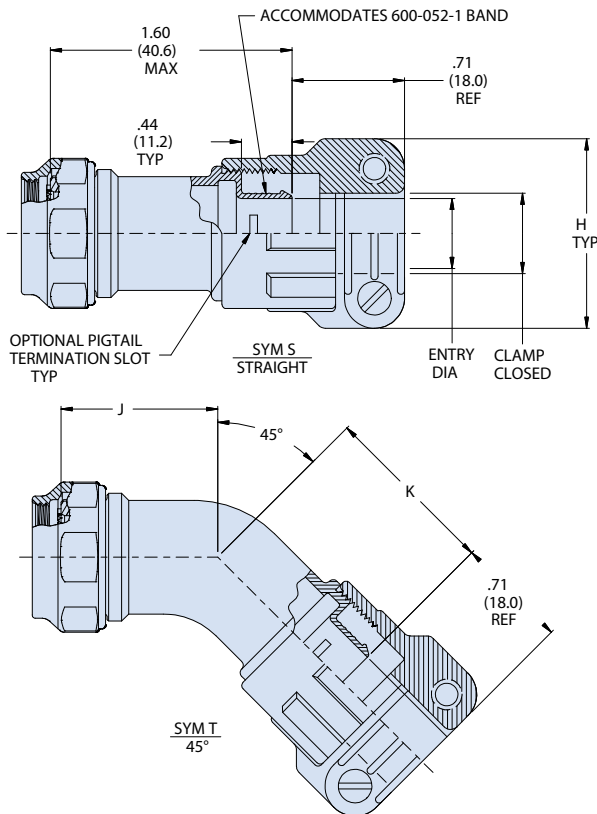
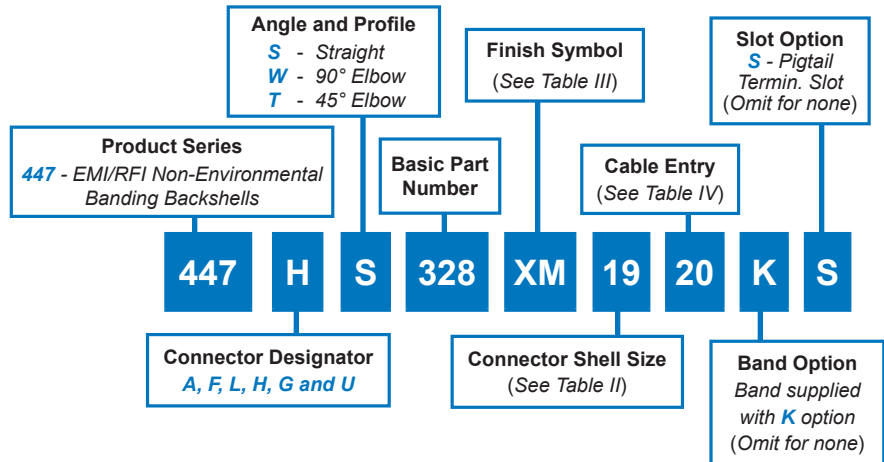
Entry Code	Entry Dia. ±.03 (0.8)	X Dia. ±.03 (0.8)
04	.250 (6.4)	.510 (13.0)
05	.310 (7.9)	.510 (13.0)
07	.440 (11.2)	.510 (13.0)
09	.560 (14.2)	.630 (16.0)
11	.680 (17.3)	.630 (16.0)
13	.810 (20.6)	.630 (16.0)
15	.940 (23.9)	.630 (16.0)
16	1.000 (25.4)	.630 (16.0)
17	1.160 (29.5)	.630 (16.0)
20	1.250 (31.8)	.630 (16.0)

**NOTES**

1. 770-001S\*\*-0 shrink boot supplied with T option. See shrink boot product page for more details.
2. O-Ring will not be supplied with Connector Designator A.
3. Consult factory for O-ring to be supplied with part less shrink boot.
4. Metric dimensions (mm) are in parenthesis and are for reference only.
5. Coupling nut supplied unplated.
6. See Table I in Intro for front-end dimensional details.

A

CONNECTOR DESIGNATOR:	
<b>A</b>	MIL-DTL-5015, -26482 Series II, and -83723 Series I and III
<b>F</b>	MIL-DTL-38999 Series I, II
<b>L</b>	MIL-DTL-38999 Series 1.5 (JN1003)
<b>H</b>	MIL-DTL-38999 Series III and IV
<b>G</b>	MIL-DTL-28840
<b>U</b>	DG123 and DG123A
<b>SELF-LOCKING</b>	
<b>ROTATABLE COUPLING</b>	
<b>STANDARD PROFILE</b>	



- NOTES**
1. Metric dimensions (mm) are in parenthesis and are for reference only.
  2. Coupling nut supplied unplated.
  3. See Table I in Intro for front-end dimensional details.

447-328

## Composite Standard Profile EMI/RFI Band-in-a-Can Backshell with Strain-Relief Clamp and Self-Locking Rotatable Coupling


Composite  
Backshells

TABLE II: CONNECTOR SHELL SIZE

Shell Size For Connector Designator*					E		F		G		J		K		Max Entry Dash No.**
A	F/L	H	G	U	±.06 (1.5)	±.09 (2.3)	Max	±.06 (1.5)	±.09 (2.3)	±.06 (1.5)	±.09 (2.3)	±.06 (1.5)	±.09 (2.3)		
08	08	09	-	-	.69 (17.5)	.88 (22.4)	1.31 (33.3)	.72 (18.3)	1.15 (29.2)					10	
10	10	11	-	08	.75 (19.1)	1.00 (25.4)	1.42 (36.1)	.75 (19.1)	1.27 (32.3)					12	
12	12	13	11	10	.81 (20.6)	1.13 (28.7)	1.57 (39.9)	.75 (19.1)	1.33 (33.8)					14	
14	14	15	13	12	.88 (22.4)	1.31 (33.3)	1.57 (39.9)	.76 (19.3)	1.37 (34.8)					16	
16	16	17	15	14	.94 (23.9)	1.38 (35.1)	1.64 (41.7)	.78 (19.8)	1.39 (35.3)					20	
18	18	19	17	16	.97 (24.6)	1.44 (36.6)	1.73 (43.9)	.79 (20.1)	1.41 (35.8)					20	
20	20	21	19	18	1.06 (26.9)	1.63 (41.4)	1.82 (46.2)	.82 (20.8)	1.43 (36.3)					22	
22	22	23	-	20	1.13 (28.7)	1.75 (44.5)	1.82 (46.2)	.86 (21.8)	1.47 (37.3)					24	
24	24	25	23	22	1.19 (30.2)	1.88 (47.8)	1.92 (48.8)	.89 (22.6)	1.50 (38.1)					32	
28	-	-	25	24	1.34 (34.0)	2.13 (54.1)	2.00 (50.8)	.92 (23.4)	1.53 (38.9)					32	

\*\*Consult factory for additional entry sizes available.

A

TABLE III: FINISH

Symbol	Finish Description
XM	2000 Hour Corrosion Resistant Electroless Nickel
XMT	2000 Hour Corrosion Resistant Ni-PTFE, Nickel-Fluorocarbon Polymer. 1000 Hour Grey™
XW	2000 Hour Corrosion Resistant Cadmium/Olive Drab over Electroless Nickel

TABLE IV: CABLE ENTRY

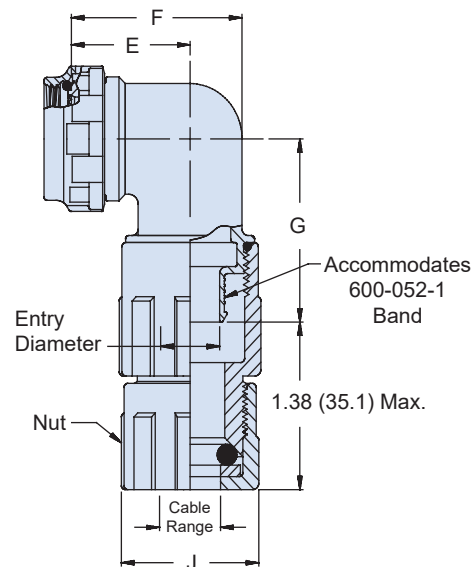
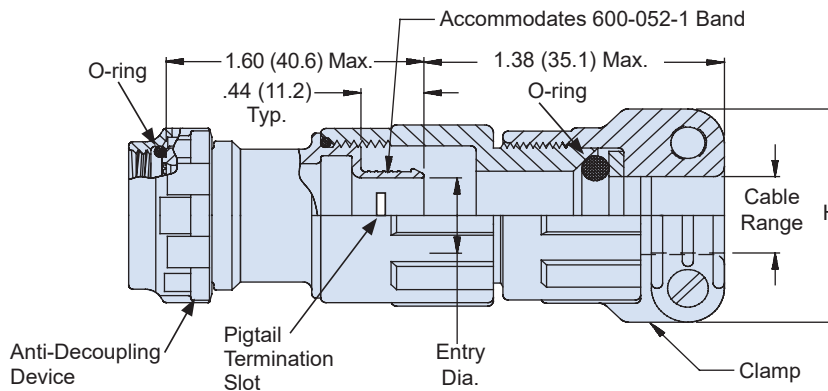
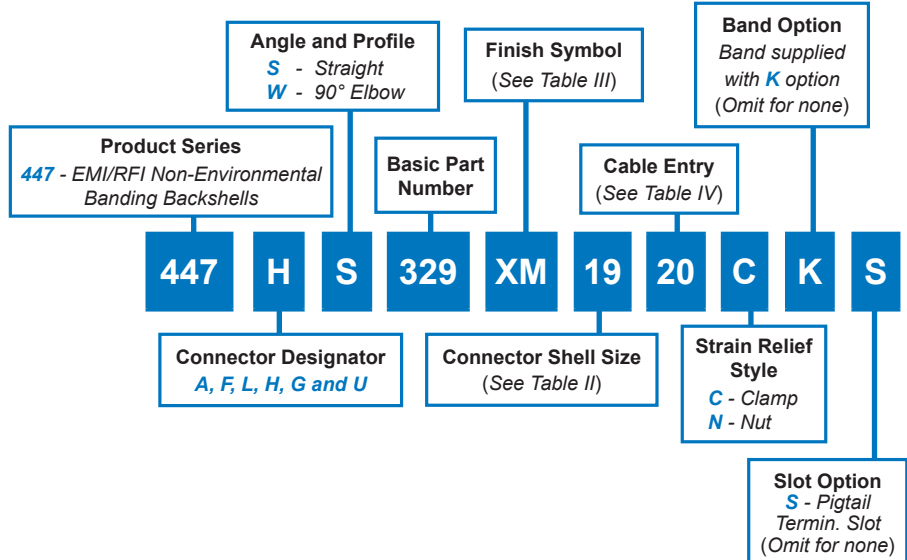
Entry Code	H		Entry Dia.*		Clamp Closed	
	±.06 (1.5)	(1.5)	±.03 (0.8)	(0.8)	±.03 (0.8)	(0.8)
10	.94 (23.9)		.22 (5.6)		.26 (6.6)	
12	1.17 (29.7)		.28 (7.1)		.34 (8.6)	
14	1.28 (32.5)		.34 (8.6)		.46 (11.7)	
16	1.41 (35.8)		.46 (11.7)		.55 (14.0)	
18	1.50 (38.1)		.55 (14.0)		.62 (15.7)	
20	1.56 (39.6)		.62 (15.7)		.70 (17.8)	
22	1.69 (42.9)		.70 (17.8)		.78 (19.8)	
24	1.81 (46.0)		.78 (19.8)		.85 (21.6)	
28	1.91 (48.5)		.85 (21.6)		.95 (24.1)	
32	2.02 (51.3)		.95 (24.1)		1.02 (25.9)	

\* Entry diameter equals maximum wire bundle diameter.

# 447-329 Composite EMI/RFI Environmental Band-in-a-Can Backshell with Strain-Relief Clamp and Self-Locking Rotatable Coupling

**A**

CONNECTOR DESIGNATOR:	
<b>A</b>	MIL-DTL-5015, -26482 Series II, and -83723 Series I and III
<b>F</b>	MIL-DTL-38999 Series I, II
<b>L</b>	MIL-DTL-38999 Series 1.5 (JN1003)
<b>H</b>	MIL-DTL-38999 Series III and IV
<b>G</b>	MIL-DTL-28840
<b>U</b>	DG123 and DG123A
<b>SELF-LOCKING</b>	
<b>ROTATABLE COUPLING</b>	
<b>STANDARD PROFILE</b>	



- NOTES**
1. Metric dimensions (mm) are in parenthesis and are for reference only.
  2. Coupling nut supplied unplated.
  3. See Table I in Intro for front-end dimensional details.

**447-329**  
**Composite EMI/RFI Environmental**  
**Band-in-a-Can Backshell with Strain-Relief Clamp**  
**and Self-Locking Rotatable Coupling**



**TABLE II: CONNECTOR SHELL SIZE**

Shell Size For					E ±.06 (1.5)	F ±.09 (2.3)	G Max	Max Entry Dash No.**
Connector Designator*								
A	F/L	H	G	U				
08	08	09	-	-	.69 (17.5)	.88 (22.4)	1.31 (33.3)	10
10	10	11	-	08	.75 (19.1)	1.00 (25.4)	1.42 (36.1)	12
12	12	13	11	10	.81 (20.6)	1.13 (28.7)	1.57 (39.9)	14
14	14	15	13	12	.88 (22.4)	1.31 (33.3)	1.57 (39.9)	16
16	16	17	15	14	.94 (23.9)	1.38 (35.1)	1.64 (41.7)	20
18	18	19	17	16	.97 (24.6)	1.44 (36.6)	1.73 (43.9)	20
20	20	21	19	18	1.06 (26.9)	1.63 (41.4)	1.82 (46.2)	22
22	22	23	-	20	1.13 (28.7)	1.75 (44.5)	1.82 (46.2)	24
24	24	25	23	22	1.19 (30.2)	1.88 (47.8)	1.92 (48.8)	28
28	-	-	25	24	1.34 (34.0)	2.13 (54.1)	2.00 (50.8)	32

\*\*Consult factory for additional entry sizes available.

**TABLE III: FINISH**

Symbol	Finish Description
XM	2000 Hour Corrosion Resistant Electroless Nickel
XMT	2000 Hour Corrosion Resistant Ni-PTFE, Nickel-Fluorocarbon Polymer. 1000 Hour Grey™
XW	2000 Hour Corrosion Resistant Cadmium/Olive Drab over Electroless Nickel

**TABLE IV: CABLE ENTRY**

Entry Code	H		J		Entry Dia.*		Cable Range **	
	±.06 (1.5)	(1.5)	±.06 (1.5)	(1.5)	±.03 (0.8)	(0.8)	Minimum	Maximum
10	.94	(23.9)	.80	(20.3)	.22	(5.6)	.13 (3.3)	.25 (6.4)
12	1.17	(29.7)	.93	(23.6)	.28	(7.1)	.25 (6.4)	.38 (9.7)
14	1.28	(32.5)	1.06	(26.9)	.34	(8.6)	.31 (7.9)	.44 (11.2)
16	1.41	(35.8)	1.22	(31.0)	.46	(11.7)	.50 (12.7)	.63 (15.9)
18	1.50	(38.1)	1.24	(31.5)	.55	(14.0)	.56 (14.2)	.69 (17.5)
20	1.56	(39.6)	1.37	(34.8)	.62	(15.7)	.63 (16.0)	.75 (19.1)
22	1.69	(42.9)	1.49	(37.8)	.70	(17.8)	.75 (19.1)	.88 (22.2)
24	1.81	(46.0)	1.62	(41.1)	.78	(19.8)	.88 (22.4)	1.00 (25.4)
28	1.91	(48.5)	1.68	(42.7)	.85	(21.6)	1.00 (25.4)	1.13 (28.6)
32	2.02	(51.3)	1.82	(46.2)	.95	(24.1)	1.13 (28.6)	1.25 (31.8)

\* Entry diameter equals maximum wire bundle diameter.

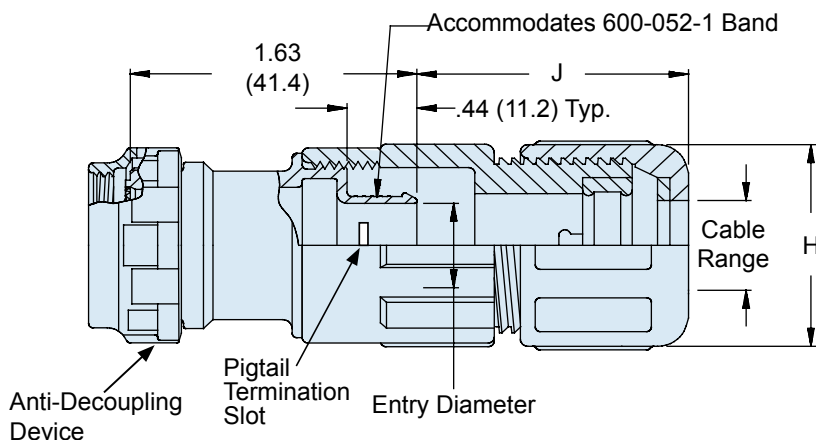
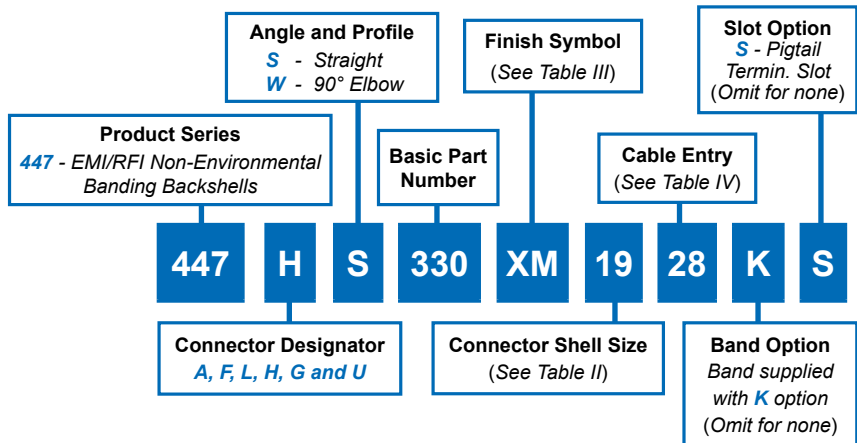
\*\* Cable range equals diameter of cable outer jacket.



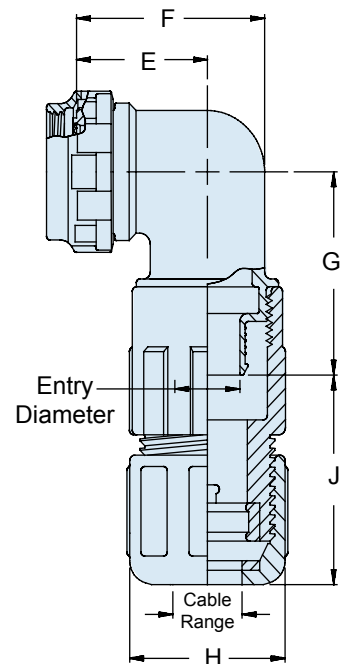
# 447-330 Composite Non-Environmental EMI/RFI Band-in-a-Can Backshell with Qwik-Clamp Strain-Relief and Self-Locking Rotatable Coupling

**A**

CONNECTOR DESIGNATOR:	
<b>A</b>	MIL-DTL-5015, -26482 Series II, and -83723 Series I and III
<b>F</b>	MIL-DTL-38999 Series I, II
<b>L</b>	MIL-DTL-38999 Series 1.5 (JN1003)
<b>H</b>	MIL-DTL-38999 Series III and IV
<b>G</b>	MIL-DTL-28840
<b>U</b>	DG123 and DG123A
<b>SELF-LOCKING</b>	
<b>ROTATABLE COUPLING</b>	
<b>STANDARD PROFILE</b>	



**US PATENT 5211576**



### NOTES

1. Metric dimensions (mm) are in parenthesis and are for reference only.
2. Coupling nut supplied unplated.
3. See Table I in Intro for front-end dimensional details.

447-330

**Composite Non-Environmental EMI/RFI  
Band-in-a-Can Backshell with Qwik-Clamp Strain-Relief  
and Self-Locking Rotatable Coupling**



Composite Backshells

A

TABLE II: CONNECTOR SHELL SIZE

Shell Size For					E	F	G	Max Entry
Connector Designator*								
A	F/L	H	G	U	±.06 (1.5)	±.09 (2.3)	±.09 (2.3)	Dash No**
08	08	09	-	-	.69 (17.5)	.88 (22.4)	1.19 (30.2)	08
10	10	11	-	08	.75 (19.1)	1.00 (25.4)	1.25 (31.8)	12
12	12	13	11	10	.81 (20.6)	1.13 (28.7)	1.31 (33.3)	16
14	14	15	13	12	.88 (22.4)	1.31 (33.3)	1.38 (35.1)	20
16	16	17	15	14	.94 (23.9)	1.38 (35.1)	1.44 (36.6)	24
18	18	19	17	16	.97 (24.6)	1.44 (36.6)	1.47 (37.3)	28
20	20	21	19	18	1.06 (26.9)	1.63 (41.4)	1.56 (39.6)	32
22	22	23	-	20	1.13 (28.7)	1.75 (44.5)	1.63 (41.4)	36
24	24	25	23	22	1.19 (30.2)	1.88 (47.8)	1.69 (42.9)	40
28	-	-	25	24	1.34 (34.0)	2.13 (54.1)	1.78 (45.2)	44

\*\*Consult factory for additional entry sizes available.

TABLE III: FINISH

Symbol	Finish Description
XM	2000 Hour Corrosion Resistant Electroless Nickel
XMT	2000 Hour Corrosion Resistant Ni-PTFE, Nickel-Fluorocarbon Polymer. <i>1000 Hour Grey™</i>
XW	2000 Hour Corrosion Resistant Cadmium/Olive Drab over Electroless Nickel

TABLE IV: CABLE ENTRY

Entry Code	H		J		Entry Dia.	Cable Range	
	±.06 (1.5)	±.06 (1.5)	±.06 (1.5)	±.06 (1.5)		Minimum	Maximum
08	.72 (18.3)	.97 (24.6)	.25 (6.4)	.10 (2.5)	.25 (6.4)	.10 (2.5)	.25 (6.4)
12	.91 (23.1)	1.11 (28.2)	.38 (9.7)	.20 (5.1)	.38 (9.7)	.20 (5.1)	.38 (9.7)
16	1.09 (27.7)	1.21 (30.7)	.50 (12.7)	.33 (8.4)	.50 (12.7)	.33 (8.4)	.50 (12.7)
20	1.22 (31.0)	1.21 (30.7)	.63 (15.9)	.45 (11.4)	.63 (15.9)	.45 (11.4)	.63 (15.9)
24	1.34 (34.0)	1.21 (30.7)	.75 (19.1)	.52 (13.2)	.75 (19.1)	.52 (13.2)	.75 (19.1)
28	1.53 (38.9)	1.36 (34.5)	.88 (22.2)	.64 (16.3)	.88 (22.2)	.64 (16.3)	.88 (22.2)
32	1.72 (43.7)	1.51 (38.4)	1.00 (25.4)	.77 (19.6)	1.00 (25.4)	.77 (19.6)	1.00 (25.4)
36	1.85 (47.0)	1.51 (38.4)	1.13 (28.6)	.86 (21.8)	1.13 (28.6)	.86 (21.8)	1.13 (28.6)
40	1.97 (50.0)	1.51 (38.4)	1.25 (31.8)	.98 (24.9)	1.25 (31.8)	.98 (24.9)	1.25 (31.8)
44	2.09 (53.1)	1.63 (41.4)	1.38 (35.1)	1.13 (28.6)	1.38 (35.1)	1.13 (28.6)	1.38 (35.1)

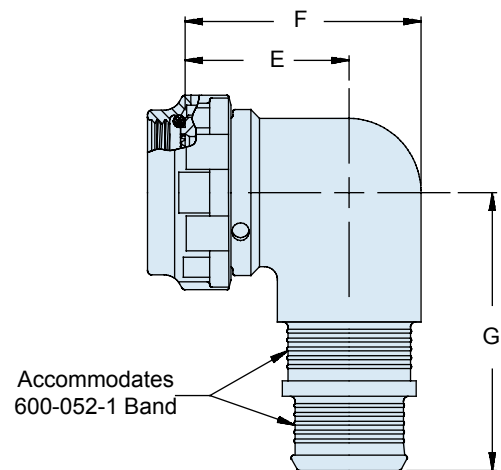
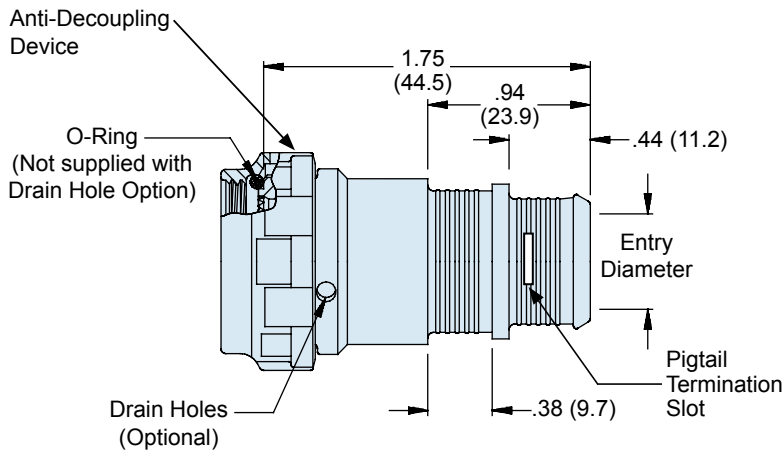
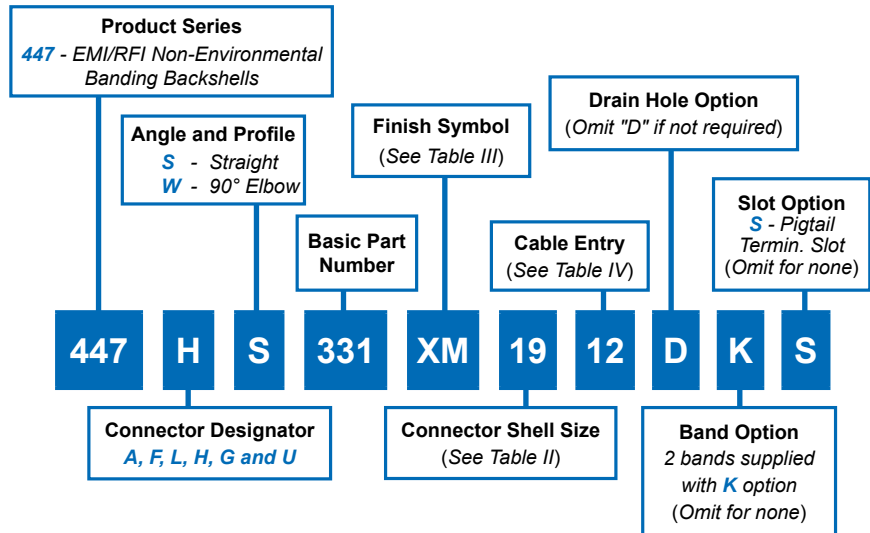
\* Entry diameter equals maximum wire bundle diameter.

\*\* Cable range equals cable outer diameter.

# 447-331 Composite EMI/RFI Dual-Banding Backshell with Self-Locking Rotatable Coupling

A

CONNECTOR DESIGNATOR:	
<b>A</b>	MIL-DTL-5015, -26482 Series II, and -83723 Series I and III
<b>F</b>	MIL-DTL-38999 Series I, II
<b>L</b>	MIL-DTL-38999 Series 1.5 (JN1003)
<b>H</b>	MIL-DTL-38999 Series III and IV
<b>G</b>	MIL-DTL-28840
<b>U</b>	DG123 and DG123A
<b>SELF-LOCKING</b>	
<b>ROTATABLE COUPLING</b>	
<b>STANDARD PROFILE</b>	



## NOTES

1. Metric dimensions (mm) are in parenthesis and are for reference only.
2. Coupling nut supplied unplated.
3. See Table I in Intro for front-end dimensional details.



**447-331**  
**Composite EMI/RFI Dual-Banding Backshell**  
**with Self-Locking Rotatable Coupling**



**TABLE II: CONNECTOR SHELL SIZE**

Shell Size For Connector Designator*					E	F	G	Max Entry
A	F/L	H	G	U	±.06 (1.5)	±.09 (2.3)	±.09 (2.3)	Dash No.**
08	08	09	-	-	.69 (17.5)	.88 (22.4)	1.69 (42.9)	04
10	10	11	-	08	.75 (19.1)	1.00 (25.4)	1.75 (44.5)	06
12	12	13	11	10	.81 (20.6)	1.13 (28.7)	1.81 (46.0)	08
14	14	15	13	12	.88 (22.4)	1.31 (33.3)	1.88 (47.8)	10
16	16	17	15	14	.94 (23.9)	1.38 (35.1)	1.94 (49.3)	12
18	18	19	17	16	.97 (24.6)	1.44 (36.6)	1.97 (50.0)	13
20	20	21	19	18	1.06 (26.9)	1.63 (41.4)	2.06 (52.3)	15
22	22	23	-	20	1.13 (28.7)	1.75 (44.5)	2.13 (54.1)	17
24	24	25	23	22	1.19 (30.2)	1.88 (47.8)	2.19 (55.6)	19
28	-	-	25	24	1.34 (34.0)	2.13 (54.1)	2.28 (57.9)	22

\*\*Consult factory for additional entry sizes available.

**TABLE III: FINISH**

Symbol	Finish Description
XM	2000 Hour Corrosion Resistant Electroless Nickel
XMT	2000 Hour Corrosion Resistant Ni-PTFE, Nickel-Fluorocarbon Polymer. <i>1000 Hour Grey™</i>
XW	2000 Hour Corrosion Resistant Cadmium/Olive Drab over Electroless Nickel

**TABLE IV: CABLE ENTRY**

Entry Code	Entry Dia. ±.03 (0.8)	Dash No.	Entry Dia. ±.03 (0.8)
03	.19 (4.8)	13	.81 (20.6)
04	.25 (6.4)	14	.88 (22.4)
05	.31 (7.9)	15	.94 (23.9)
06	.38 (9.7)	16	1.00 (25.4)
07	.44 (11.2)	17	1.06 (26.9)
08	.50 (12.7)	18	1.13 (28.7)
09	.56 (14.2)	19	1.19 (30.2)
10	.63 (16.0)	20	1.25 (31.8)
11	.69 (17.5)	22	1.38 (35.1)
12	.75 (19.1)		

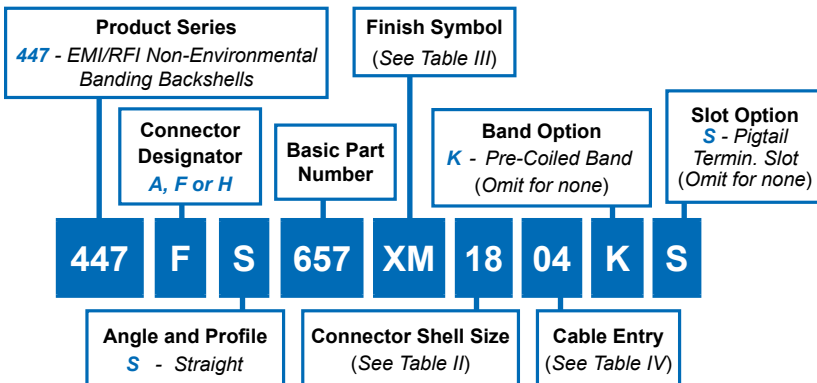
A

**CONNECTOR DESIGNATOR:**

<b>A</b>	MIL-DTL-5015, -26482 Series II, and -83723 Series I and III
<b>F</b>	MIL-DTL-38999 Series I, II
<b>H</b>	MIL-DTL-38999 Series III and IV

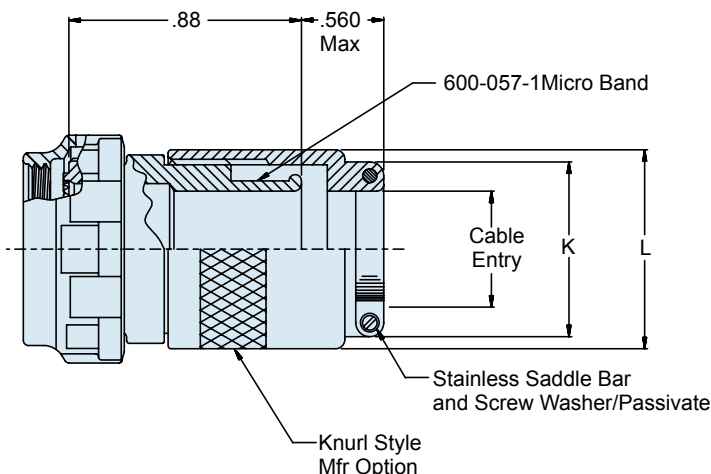
**ROTATABLE COUPLING**

**STANDARD PROFILE**



- NOTES**
- Metric dimensions (mm) are in parenthesis and are for reference only.
  - See Table I in Intro for front-end dimensional details.

For angled part requirements, use in conjunction with Glenair 327-060 Extenders



**TABLE II SHELL SIZE**

Shell Size			Max Dash Number (Table II)	
A	F	H	A	F, H
08	08	09	01	01
10	10	11	01	02
12	12	13	04	04
14	14	15	04	05
16	16	17	05	06
18	18	19	06	06
20	20	21	07	07
22	22	23	08	08
24	24	25	09	09
28	-	-	10	10
32	-	-	10	10
36	-	-	10	10
40	-	-	10	10

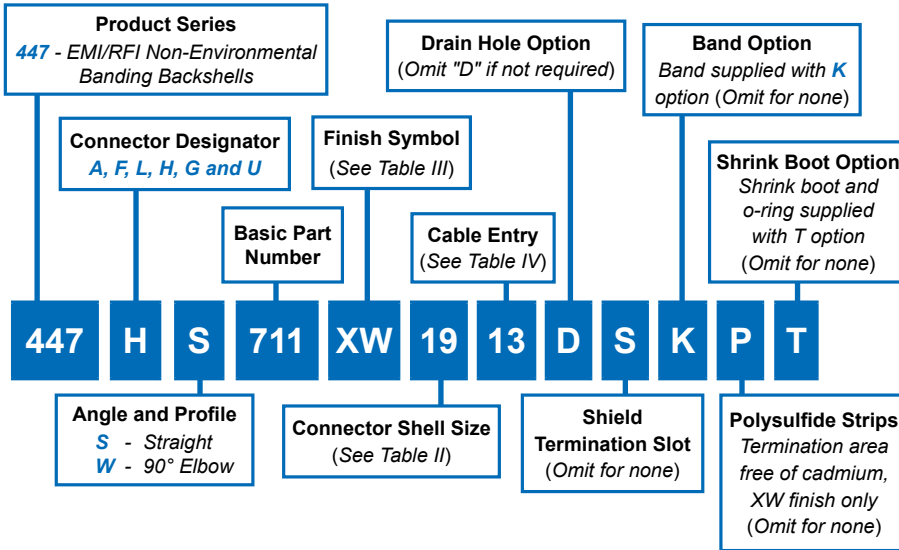
**TABLE III: FINISH**

Symbol	Finish Description
XM	2000 Hour Corrosion Resistant Electroless Nickel
XMT	2000 Hour Corrosion Resistant Ni-PTFE, Nickel-Fluorocarbon Polymer. 1000 Hour Grey™
XW	2000 Hour Corrosion Resistant Cadmium/Olive Drab over Electroless Nickel

**TABLE IV: CABLE ENTRY**

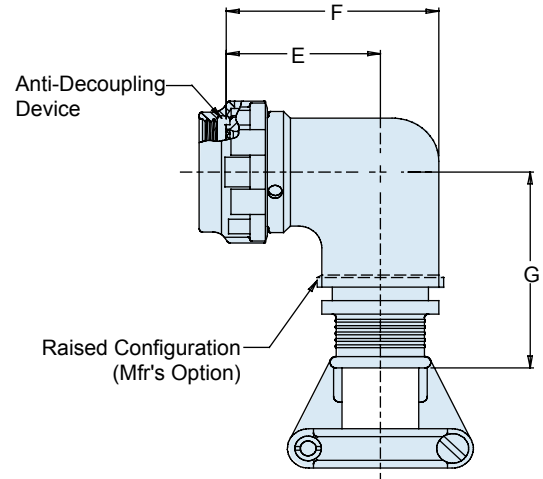
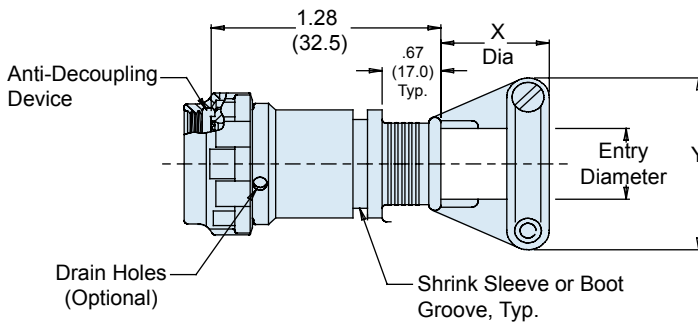
Dash Number	K Max	L Max	Cable Entry	
			Min	Max
01	.843 (21.4)	.78 (19.8)	.125 (3.2)	.250 (6.4)
02	.968 (24.6)	.97 (24.6)	.156 (4.0)	.375 (9.5)
03	1.046 (26.6)	1.05 (26.7)	.250 (6.4)	.438 (11.1)
04	1.156 (29.4)	1.15 (29.2)	.280 (7.1)	.500 (12.7)
05	1.218 (30.9)	1.22 (31.0)	.375 (9.5)	.625 (15.9)
06	1.343 (34.1)	1.34 (34.0)	.500 (12.7)	.750 (19.1)
07	1.468 (37.3)	1.47 (37.3)	.625 (15.9)	.875 (22.2)
08	1.593 (40.5)	1.59 (40.4)	.750 (19.1)	1.000 (25.4)
09	1.718 (43.6)	1.72 (43.7)	.875 (22.2)	1.125 (28.6)
10	1.843 (46.8)	1.84 (46.7)	1.000 (25.4)	1.250 (31.8)

# 447-711 Composite EMI/RFI Banding Backshell with Strain Relief and Self-Locking Rotatable Coupling



Entry Code	Entry Dia. ±.03 (0.8)	X Dia. ±.03 (0.8)	Y Dia. ±.03 (0.8)
04	.250 (6.4)	.51 (13.0)	.875 (22.2)
05	.310 (7.9)	.51 (13.0)	.936 (23.8)
07	.420 (10.7)	.51 (13.0)	1.172 (29.8)
09	.530 (13.5)	.63 (16.0)	1.281 (32.5)
10	.630 (16.0)	.63 (16.0)	1.406 (35.7)
12	.750 (19.1)	.63 (16.0)	1.500 (38.1)
13	.810 (20.6)	.63 (16.0)	1.562 (39.7)
15	.940 (23.9)	.63 (16.0)	1.687 (42.8)
16	1.00 (25.4)	.63 (16.0)	1.812 (46.0)
19	1.16 (29.5)	.63 (16.0)	1.912 (48.6)

NOTE: Coupling Nut Supplied Unplated



Shell Size For Connector Designator*					E	F	G	Max Entry
A	F/L	H	G	U	±.06 (1.5)	±.09 (2.3)	±.09 (2.3)	Dash No.**
08	08	09	-	-	.69 (17.5)	.88 (22.4)	1.36 (34.5)	04
10	10	11	-	08	.75 (19.1)	1.00 (25.4)	1.42 (36.1)	05
12	12	13	11	10	.81 (20.6)	1.13 (28.7)	1.48 (37.6)	07
14	14	15	13	12	.88 (22.4)	1.31 (33.3)	1.55 (39.4)	09
16	16	17	15	14	.94 (23.9)	1.38 (35.1)	1.61 (40.9)	11
18	18	19	17	16	.97 (24.6)	1.44 (36.6)	1.64 (41.7)	13
20	20	21	19	18	1.06 (26.9)	1.63 (41.4)	1.73 (43.9)	15
22	22	23	-	20	1.13 (28.7)	1.75 (44.5)	1.80 (45.7)	17
24	24	25	23	22	1.19 (30.2)	1.88 (47.8)	1.86 (47.2)	20

\*\*Consult factory for additional entry sizes available.  
Consult factory for O-Ring to be supplied with part less shrink boot.

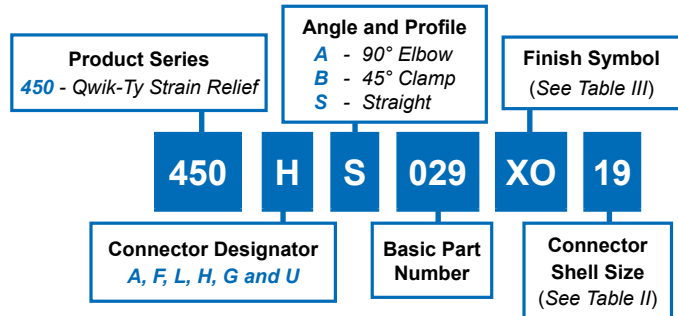
Symbol	Finish Description
XM	2000 Hour Corrosion Resistant Electroless Nickel
XMT	2000 Hour Corrosion Resistant Ni-PTFE, Nickel-Fluorocarbon Polymer. 1000 Hour Grey™
XW	2000 Hour Corrosion Resistant Cadmium/Olive Drab over Electroless Nickel



# 450-029 Composite Qwik-Ty® Strain-Relief with Self-Locking Rotatable Coupling Straight, 45° and 90°

A

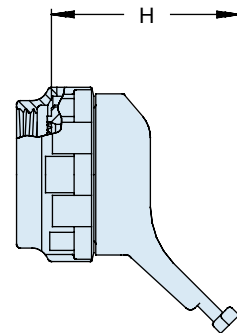
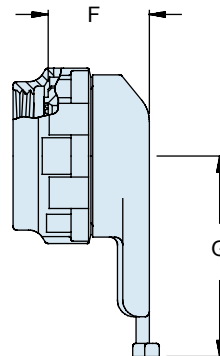
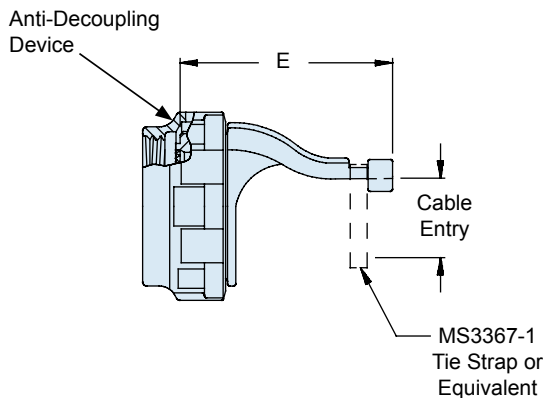
CONNECTOR DESIGNATOR:	
<b>A</b>	MIL-DTL-5015, -26482 Series II, and -83723 Series I and III
<b>F</b>	MIL-DTL-38999 Series I, II
<b>L</b>	MIL-DTL-38999 Series 1.5 (JN1003)
<b>H</b>	MIL-DTL-38999 Series III and IV
<b>G</b>	MIL-DTL-28840
<b>U</b>	DG123 and DG123A
<b>SELF-LOCKING</b>	
<b>ROTATABLE COUPLING</b>	
<b>LOW PROFILE</b>	



- NOTES**
- Metric dimensions (mm) are in parenthesis and are for reference only.
  - See Table I in Intro for front-end dimensional details.

**TABLE III: FINISH**

Symbol	Finish Description
XB	No Plating - Black Material
XO	No Plating - Brown Material



**TABLE II: CONNECTOR SHELL SIZE ORDER NUMBER**

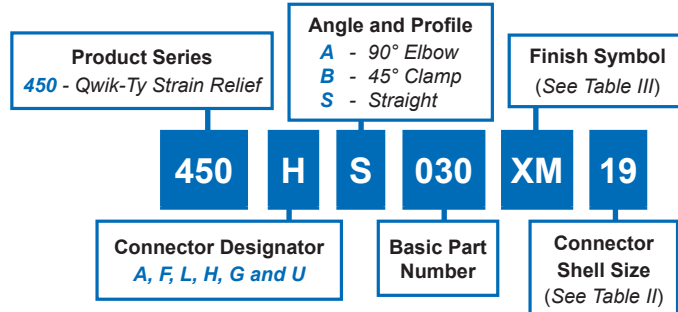
Shell Size For Connector Designator*					E Code A,F,H	E Code G,U	F	G	H	Cable Entry
A	F/L	H	G	U	Max	Max	Max	Max	Max	Max
08	08	09	-	-	1.14 (29.0)	-	.75 (19.0)	1.22 (31.0)	1.14 (29.0)	.25 (6.4)
10	10	11	-	08	1.14 (29.0)	1.30 (33.0)	.75 (19.0)	1.29 (32.8)	1.14 (29.0)	.38 (9.7)
12	12	13	11	10	1.20 (30.5)	1.36 (34.5)	.75 (19.0)	1.62 (41.1)	1.14 (29.0)	.50 (12.7)
14	14	15	13	12	1.38 (35.1)	1.54 (39.1)	.75 (19.0)	1.66 (42.2)	1.64 (41.7)	.63 (16.0)
16	16	17	15	14	1.38 (35.1)	1.54 (39.1)	.75 (19.0)	1.72 (43.7)	1.64 (41.7)	.75 (19.1)
18	18	19	17	16	1.44 (36.6)	1.69 (42.9)	.75 (19.0)	1.72 (43.7)	1.74 (44.2)	.81 (21.8)
20	20	21	19	18	1.57 (39.9)	1.73 (43.9)	.75 (19.0)	1.79 (45.5)	1.74 (44.2)	.94 (23.9)
22	22	23	-	20	1.69 (42.9)	1.91 (48.5)	.75 (19.0)	1.85 (47.0)	1.74 (44.2)	1.06 (26.9)
24	24	25	23	22	1.83 (46.5)	1.99 (50.5)	.75 (19.0)	1.91 (48.5)	1.95 (49.5)	1.19 (30.2)
28	-	-	25	24	1.99 (50.5)	2.15 (54.6)	.75 (19.0)	2.07 (52.6)	n/a	1.38 (35.1)

# 450-030 Composite Qwik-Ty® Strain-Relief with Self-Locking Rotatable Coupling and Ground Lug Straight, 45° and 90°



Composite Backshells

CONNECTOR DESIGNATOR:	
<b>A</b>	MIL-DTL-5015, -26482 Series II, and -83723 Series I and III
<b>F</b>	MIL-DTL-38999 Series I, II
<b>L</b>	MIL-DTL-38999 Series 1.5 (JN1003)
<b>H</b>	MIL-DTL-38999 Series III and IV
<b>G</b>	MIL-DTL-28840
<b>U</b>	DG123 and DG123A
<b>SELF-LOCKING</b>	
<b>ROTATABLE COUPLING</b>	
<b>LOW PROFILE</b>	



A

TABLE III: FINISH	
Symbol	Finish Description
XM	2000 Hour Corrosion Resistant Electroless Nickel
XMT	2000 Hour Corrosion Resistant Ni-PTFE, Nickel-Fluorocarbon Polymer. 1000 Hour Grey™
XW	2000 Hour Corrosion Resistant Cadmium/Olive Drab over Electroless Nickel
XB	No Plating - Black Material
XO	No Plating - Brown Material

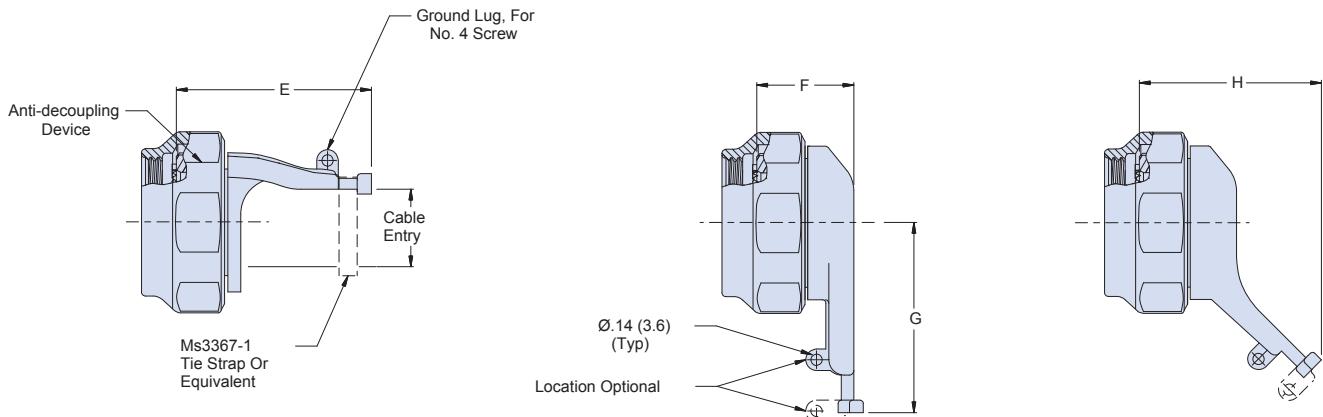
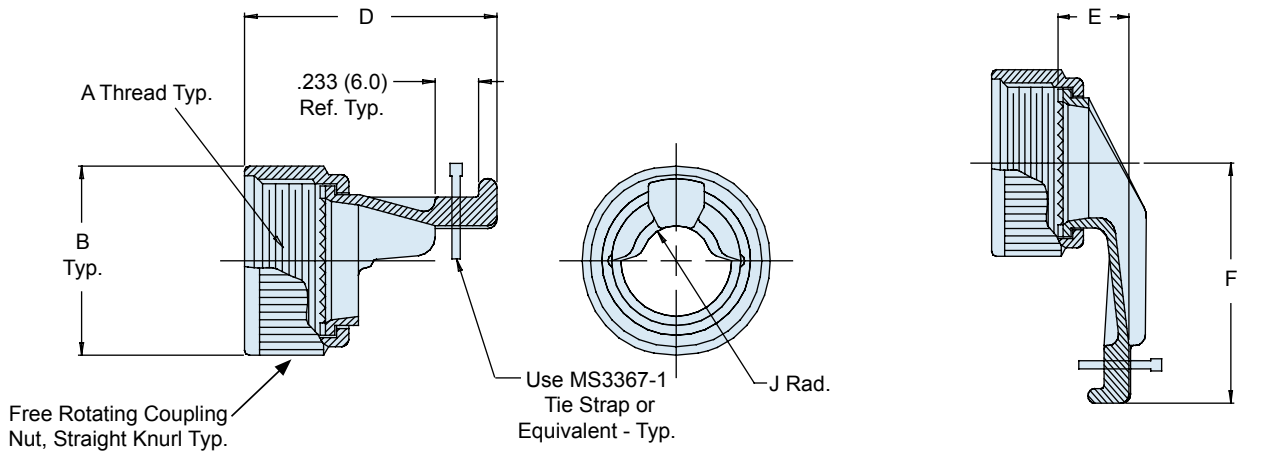
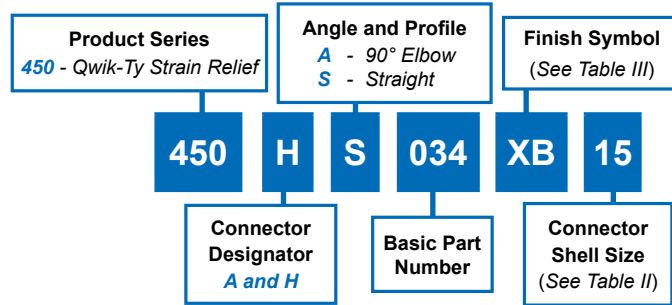


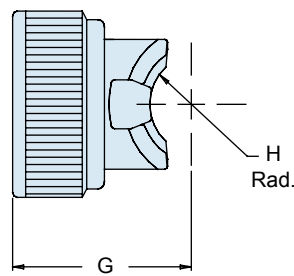
TABLE II: CONNECTOR SHELL SIZE ORDER NUMBER																
Shell Size For Connector Designator*					E Code A,F,H		E Code G,U		F	G	H	Cable Entry				
A	F/L	H	G	U	Max	Max	Max	Max	Max	Max	Max	Max	Max	Max	Max	
08	08	09	-	-	1.14	(29.0)	-	.75	(19.0)	1.22	(31.0)	1.14	(29.0)	.25	(6.4)	
10	10	11	-	08	1.14	(29.0)	1.30	(33.0)	.75	(19.0)	1.29	(32.8)	1.14	(29.0)	.38	(9.7)
12	12	13	11	10	1.20	(30.5)	1.36	(34.5)	.75	(19.0)	1.62	(41.1)	1.14	(29.0)	.50	(12.7)
14	14	15	13	12	1.38	(35.1)	1.54	(39.1)	.75	(19.0)	1.66	(42.2)	1.64	(41.7)	.63	(16.0)
16	16	17	15	14	1.38	(35.1)	1.54	(39.1)	.75	(19.0)	1.72	(43.7)	1.64	(41.7)	.75	(19.1)
18	18	19	17	16	1.44	(36.6)	1.69	(42.9)	.75	(19.0)	1.72	(43.7)	1.74	(44.2)	.81	(21.8)
20	20	21	19	18	1.57	(39.9)	1.73	(43.9)	.75	(19.0)	1.79	(45.5)	1.74	(44.2)	.94	(23.9)
22	22	23	-	20	1.69	(42.9)	1.91	(48.5)	.75	(19.0)	1.85	(47.0)	1.74	(44.2)	1.06	(26.9)
24	24	25	23	22	1.83	(46.5)	1.99	(50.5)	.75	(19.0)	1.91	(48.5)	1.95	(49.5)	1.19	(30.2)
28	-	-	25	24	1.99	(50.5)	2.15	(54.6)	.75	(19.0)	2.07	(52.6)	n/a		1.38	(35.1)

**A**

CONNECTOR DESIGNATOR:	
<b>A</b>	MIL-DTL-5015, -26482 Series II, and -83723 Series I and III
<b>H</b>	MIL-DTL-38999 Series III and IV
<b>ROTATABLE COUPLING</b>	
<b>LOW PROFILE</b>	



- NOTES**
1. Metric dimensions (mm) are in parenthesis and are for reference only.
  2. See Table I in Intro for front-end dimensional details.



**450-034**  
**Composite Qwik-Ty® Strain-Relief**  
**with Free-Rotating Coupling**  
**90° and 45°**



**TABLE II: CONNECTOR SHELL SIZE & CABLE ENTRY**

Shell Size*		B Dia	D	E	F
A	H	Max	Max	Max	Max
08	09	.640 (16.3)	1.107 (28.1)	.472 (12.0)	.886 (22.5)
10	11	.765 (19.4)	1.107 (28.1)	.472 (12.0)	.945 (24.0)
12	13	.890 (22.6)	1.166 (29.6)	.492 (12.5)	1.004 (25.5)
14	15	1.015 (25.8)	1.268 (32.2)	.492 (12.5)	1.319 (33.5)
16	17	1.140 (29.0)	1.270 (32.3)	.452 (11.5)	1.378 (35.0)
18	19	1.265 (32.1)	1.418 (36.0)	.492 (12.5)	1.476 (37.5)
20	21	1.390 (35.3)	1.548 (39.3)	.472 (12.0)	1.515 (38.5)
22	23	1.454 (36.9)	1.666 (42.3)	.472 (12.0)	1.575 (40.0)
24	25	1.594 (40.5)	1.796 (45.6)	.472 (12.0)	1.653 (42.0)

\* Even Number Shell Size, Code A  
 Odd Number Shell Size, Code H

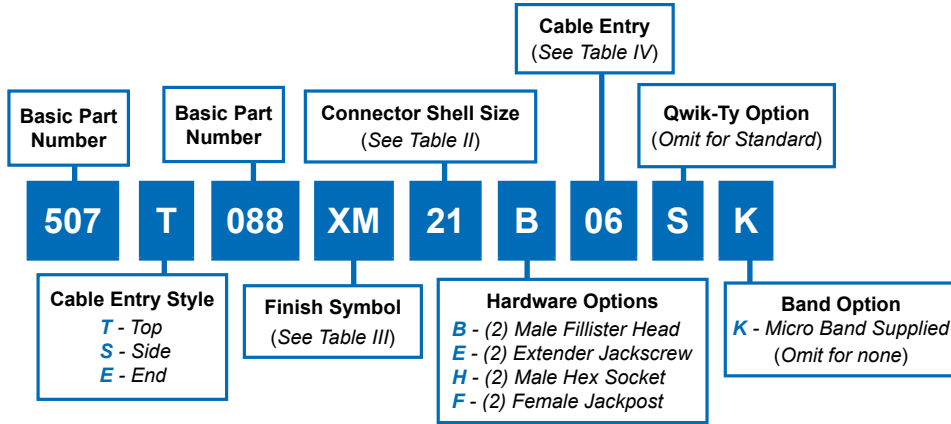
**TABLE II: CONNECTOR SHELL SIZE & CABLE ENTRY (CONT.)**

Shell Size*	G Max	H Rad. Max	J Rad. Max	Weight In Grams	
				Straight	90°
08/09	.945 (24.0)	.197 (5.0)	.098 (2.5)	1.8	1.9
10/11	.945 (24.0)	.197 (5.0)	.138 (3.5)	2.3	2.6
12/13	.945 (24.0)	.197 (5.0)	.157 (4.0)	2.9	3.2
14/15	1.023 (26.0)	.275 (7.0)	.197 (5.0)	3.3	3.8
16/17	1.023 (26.0)	.295 (7.5)	.236 (6.0)	3.9	4.6
18/19	1.102 (28.0)	.335 (8.5)	.295 (7.5)	5.1	5.7
20/21	1.161 (29.5)	.394 (10.0)	.295 (7.5)	5.8	6.4
22/23	1.161 (29.5)	.394 (10.0)	.335 (8.5)	7.0	7.4
24/25	1.319 (33.5)	.551 (14.0)	.374 (9.5)	8.6	9.3

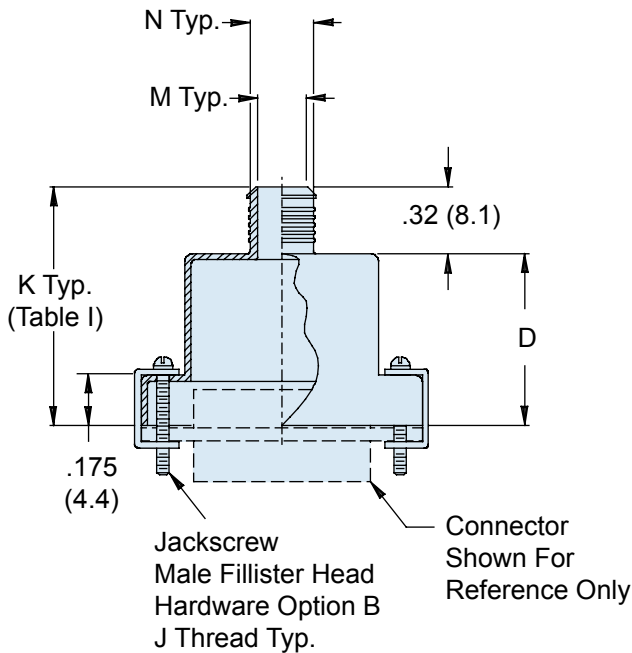
**TABLE III: FINISH**

Symbol	Finish Description
XB	No Plating - Black Material (Non-Conductive Finish)
XO	No Plating - Brown Material (Non-Conductive Finish)

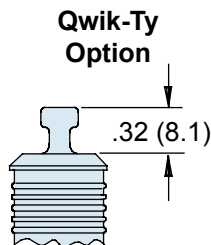
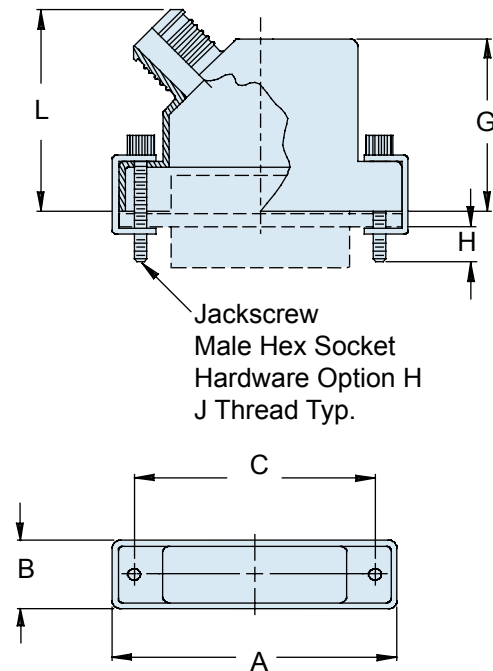
A



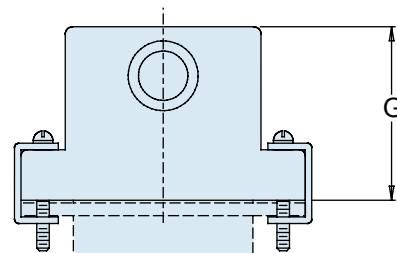
**STYLE T - TOP ENTRY**



**STYLE E - 45° ENTRY**



**STYLE S SIDE ENTRY**





**507-088**  
**Composite RFI/EMI Banding Backshell**  
**for MIL-DTL-83513 Micro-D Connectors**



**TABLE II: CONNECTOR SHELL SIZE ORDER NUMBER**

SHELL SIZE	A	B	C	D	G
09	.775 (19.7)	.36 (9.1)	.565 (14.4)	.43 (10.9)	.650 (16.5)
15	.925 (23.5)	.36 (9.1)	.715 (18.2)	.44 (11.2)	.700 (17.8)
21	1.075 (27.3)	.36 (9.1)	.865 (22.0)	.56 (14.2)	.735 (18.7)
25	1.175 (29.8)	.36 (9.1)	.965 (24.5)	.62 (15.7)	.800 (20.3)
31	1.325 (33.7)	.36 (9.1)	1.115 (28.3)	.68 (17.3)	.860 (21.8)
37	1.475 (37.5)	.36 (9.1)	1.265 (32.1)	.72 (18.3)	.925 (23.5)
51	1.425 (36.2)	.40 (10.2)	1.215 (30.9)	.75 (19.1)	.975 (24.8)
100	2.160 (54.9)	.45 (11.4)	1.800 (45.7)	.81 (20.6)	1.050 (26.7)

SHELL SIZE	H	J THREAD	K ±.03 (0.8)	L MAX
09	.154 (3.9)	2-56 UNC-2	.75 (19.1)	1.00 (25.4)
15	.154 (3.9)	2-56 UNC-2	.76 (19.3)	1.03 (26.2)
21	.154 (3.9)	2-56 UNC-2	.88 (22.4)	1.05 (26.7)
25	.154 (3.9)	2-56 UNC-2	.94 (23.9)	1.09 (27.7)
31	.154 (3.9)	2-56 UNC-2	1.00 (25.4)	1.13 (28.7)
37	.154 (3.9)	2-56 UNC-2	1.04 (26.4)	1.16 (29.5)
51	.154 (3.9)	2-56 UNC-2	1.07 (27.2)	1.25 (31.8)
100	.194 (4.9)	4-40 UNC-2	1.13 (28.7)	1.32 (33.5)

**TABLE III: FINISH**

Symbol	Finish Description
XM	2000 Hour Corrosion Resistant Electroless Nickel
XMT	2000 Hour Corrosion Resistant Ni-PTFE, Nickel-Fluorocarbon Polymer. <i>1000 Hour Grey™</i>
XW	2000 Hour Corrosion Resistant Cadmium/Olive Drab over Electroless Nickel

**TABLE IV: CABLE ENTRY**

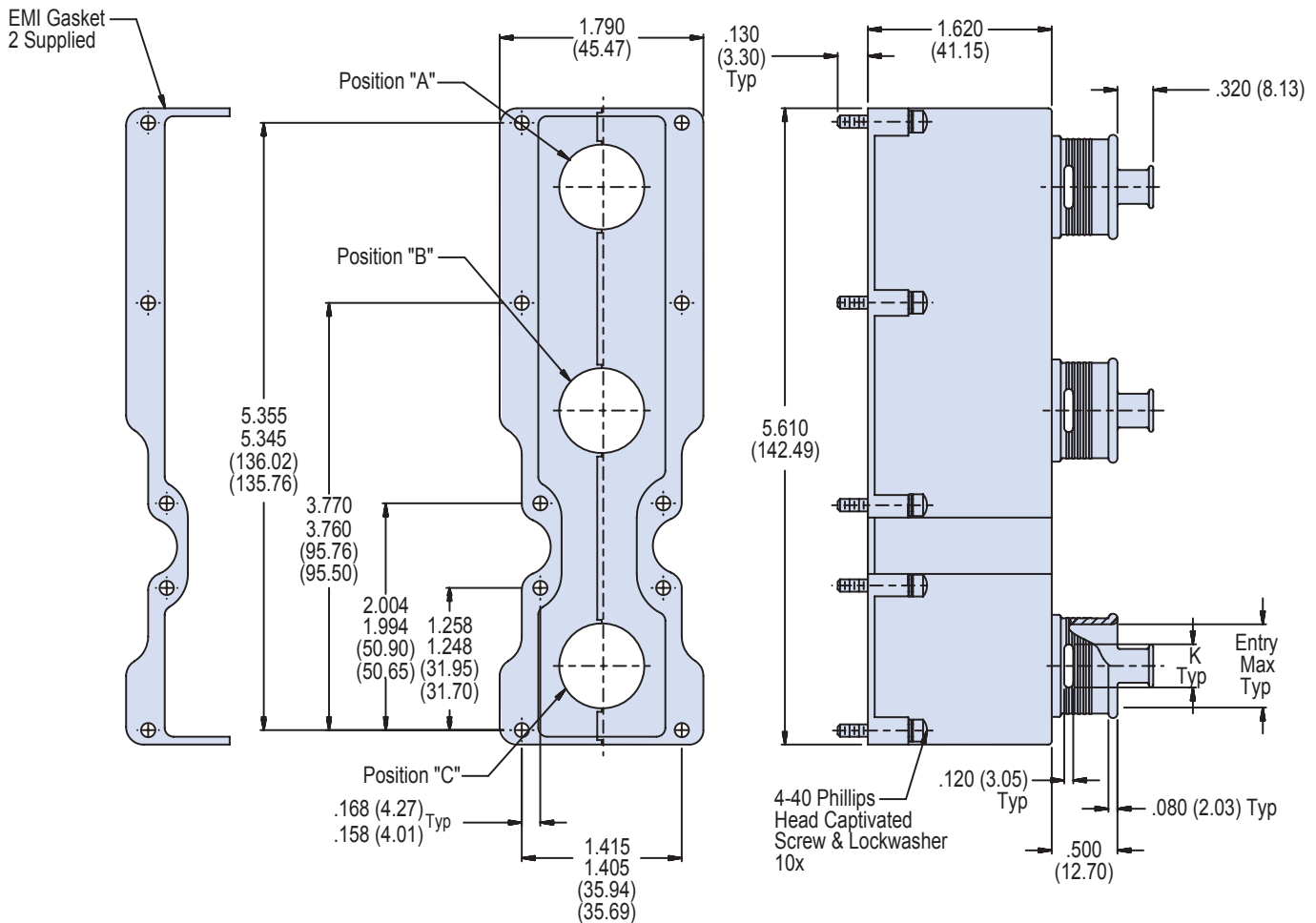
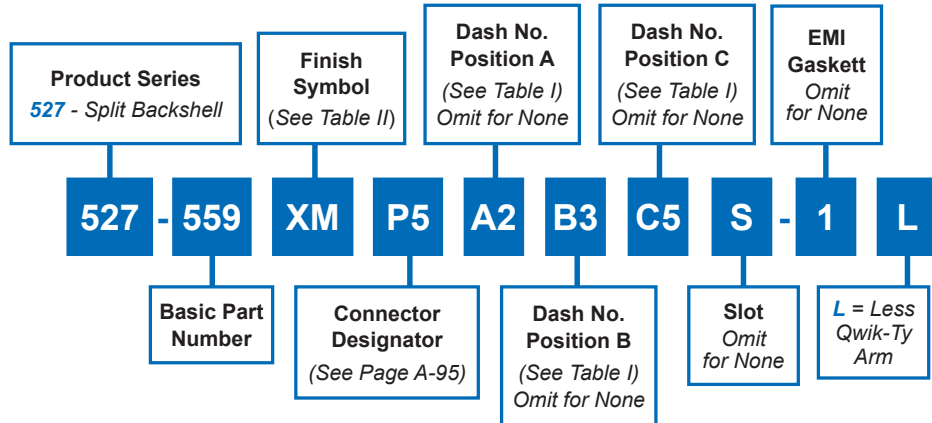
Entry Code	Shell Size	M Entry Dia	N Dia
04	09 THRU 100	.125 (3.2)	.219 (5.6)
05	09 THRU 100	.156 (4.0)	.250 (6.4)
06	09 THRU 100	.188 (4.8)	.281 (7.1)
07	09 THRU 100	.219 (5.6)	.313 (8.0)
08	09 THRU 100	.250 (6.4)	.344 (8.7)
09	31 THRU 100	.281 (7.1)	.375 (9.5)
10	51 THRU 100	.312 (7.9)	.406 (10.3)
11	100 ONLY	.344 (8.7)	.438 (11.1)
12	100 ONLY	.375 (9.5)	.469 (11.9)

**APPLICATION NOTES**

1. Metric dimensions (mm) are in parentheses and are for reference only.
2. These composite backshells meet the requirements of SAE AIR 4567 and AS85049.
3. See Table I in Intro for front-end dimensional details.

# 527-559 RFI/EMI Composite Split Backshell Assembly for Size 2 ARINC 600 Series Connector

A



527-559  
**RF/EMI Composite Split Backshell Assembly**  
 for Size 2 ARINC 600 Series Connector



ARINC 600 Series connector backshells are designed to replace the insert retainer plates. Due to non-standard modifications by the connector manufacturer, the backshell may require special design alterations to mate properly. The following should be used to determine if a backshell modification is required. Prior to ordering, consult a factory with connector part numbers not shown to ensure a proper fit:

**TABLE I: Dash Number and Dimensions**

Dash No.	Entry Dia	K Dim
4	.500 (12.70)	.380 (9.65)
5	.630 (16.00)	.470 (11.94)
6	.750 (19.05)	.560 (14.22)
8	1.000 (25.40)	.690 (17.53)
9	1.120 (28.45)	.780 (19.81)

**CONNECTOR DESIGNATOR:**

<b>P</b>	All manufacturers' plug and receptacle shells except for those listed below (prior to ordering, consult factory with connector part numbers not listed below to ensure a proper fit):
<b>P1</b>	Cannon BKAD****322 Series Plug
<b>P2</b>	Cannon/Radial Environmental Plug
<b>P3</b>	Cannon/Boeing BACC66 Plug
<b>P5</b>	Radial/Boeing BACC66 Plug
<b>P6</b>	Cannon BKAC & BKAE****322 Series Environmental Plug

**TABLE II: FINISH**

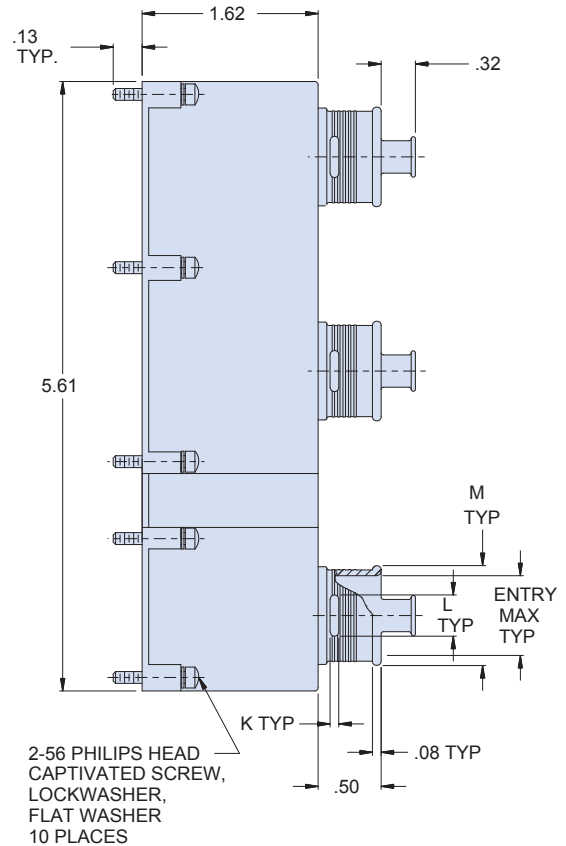
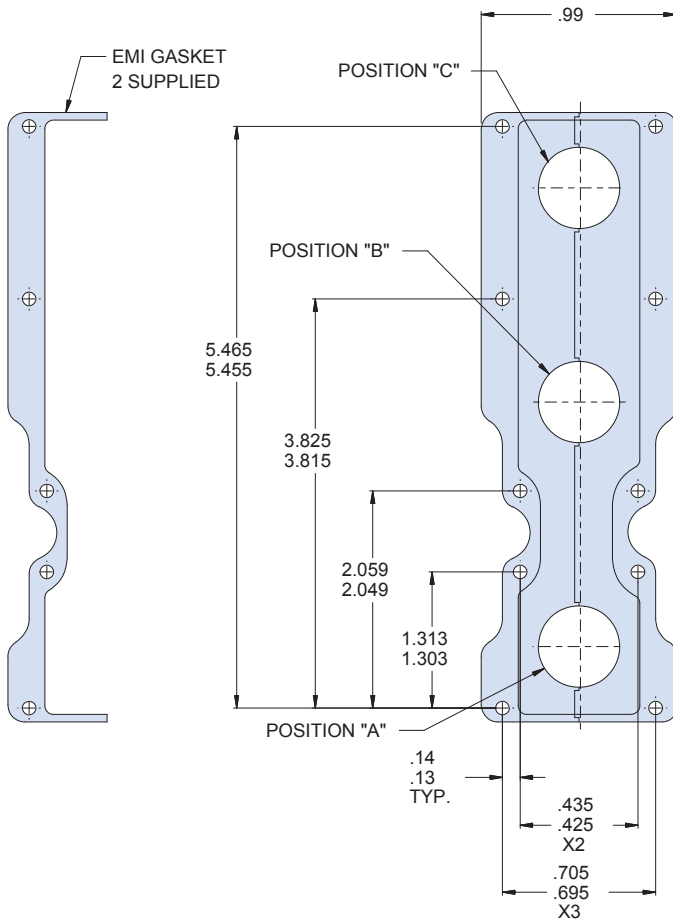
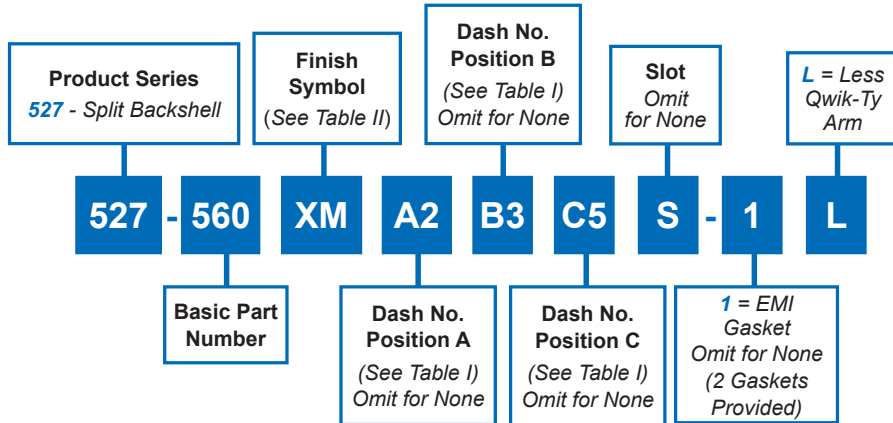
Symbol	Finish Description
XM	2000 Hour Corrosion Resistant Electroless Nickel
XO	No Plating
XMT	2000 Hour Corrosion Resistant Ni-PTFE, Nickel-Fluorocarbon Polymer. 1000 Hour Grey™
XW	2000 Hour Corrosion Resistant Cadmium/ Olive Drab over Electroless Nickel

**APPLICATION NOTES**

1. Assembly identified with manufacturer's name and P/N, space permitting.	3. Existing insert retainer in conjunction with supplied screws.
2. Material/Finish: Backshell - High grade engineering thermoplastic/See Table II. Gasket - Metex/N.A Hardware - CRES/Passivate.	4. Metric dimensions (mm) are indicated in parentheses.

# 527-560 RFI/EMI Composite Split Backshell Assembly for Size 1 ARINC 600 Series Connector

A



527-560  
**RFI/EMI Composite Split Backshell Assembly**  
 for Size 1 ARINC 600 Series Connector



ARINC 600 Series connector backshells are designed to replace the insert retainer plates. Due to non-standard modifications by the connector manufacturer, the backshell may require special design alterations to mate properly. The following should be used to determine if a backshell modification is required. Prior to ordering, consult a factory with connector part numbers not shown to ensure a proper fit:

CONNECTOR DESIGNATOR:	
<b>P</b>	All manufacturers' plug and receptacle shells except for those listed below (prior to ordering, consult factory with connector part numbers not listed below to ensure a proper fit):
<b>P1</b>	Cannon BKAD****322 Series Plug
<b>P2</b>	Cannon/Radial Environmental Plug
<b>P3</b>	Cannon/Boeing BACC66 Plug
<b>P5</b>	Radial/Boeing BACC66 Plug
<b>P6</b>	Cannon BKAC & BKAE****322 Series Environmental Plug

TABLE I: Dash Number & Dimensions						
Dash No.	Entry Dia	K Dim	L Dim	M Max		
2	.250 (6.35)	.080 (2.03)	.220 (5.59)	.475 (12.07)		
3	.380 (9.65)	.080 (2.03)	.280 (7.11)	.605 (15.37)		
4	.500 (12.7)	.080 (2.03)	.330 (8.38)	.725 (18.42)		
5	.630 (16.00)	.080 (2.03)	.420 (10.67)	.855 (21.72)		
6	.750 (19.05)	.080 (2.03)	.500 (12.70)	.975 (24.77)		
7	.870 (22.10)	.080 (2.03)	.560 (14.22)	1.095 (27.81)		

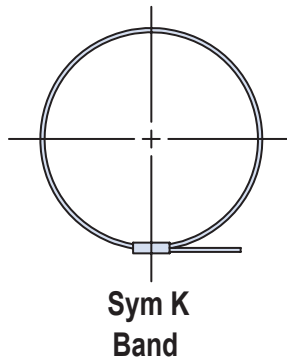
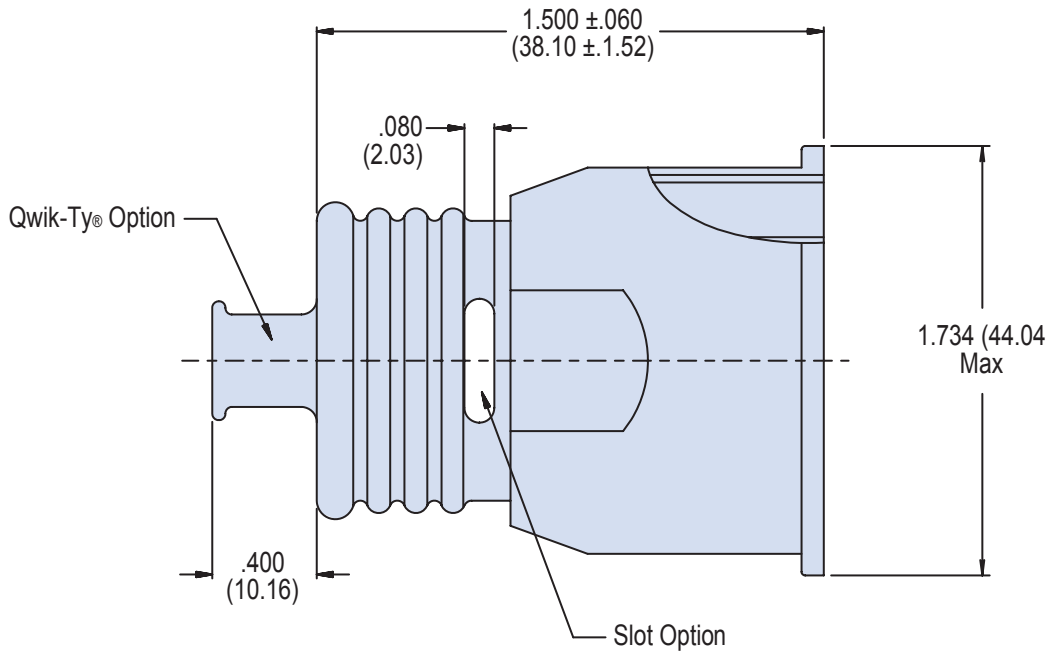
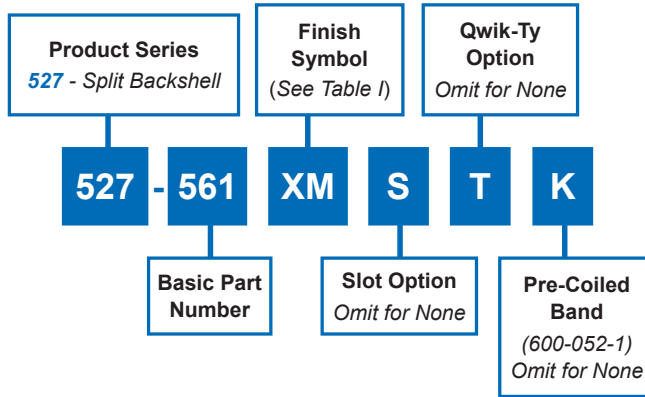
TABLE II: FINISH	
Symbol	Finish Description
XM	2000 Hour Corrosion Resistant Electroless Nickel
XB	No Plating, Black
XMT	2000 Hour Corrosion Resistant Ni-PTFE, Nickel-Fluorocarbon Polymer. 1000 Hour Grey™
XW	2000 Hour Corrosion Resistant Cadmium/Olive Drab over Electroless Nickel

APPLICATION NOTES	
1. Assembly identified with manufacturer's name and P/N, space permitting.	3. Existing insert retainer in conjunction with supplied screws.
2. Material/Finish: Backshell - High grade engineering thermoplastic/See Table II. Gasket - Metex/N.A Hardware - CRES/Passivate.	4. Metric dimensions (mm) are indicated in parentheses.

# 527-561 RFI/EMI Composite Split Banding (DPXB) Backshell for MIL-DTL-81659 Connector

A

CONNECTOR DESIGNATOR:	
?	MIL-DTL-81659



**527-561**  
**RFI/EMI Composite Split Banding (DPXB) Backshell**  
 for MIL-DTL-81659 Connector



Composite Backshells

**A**

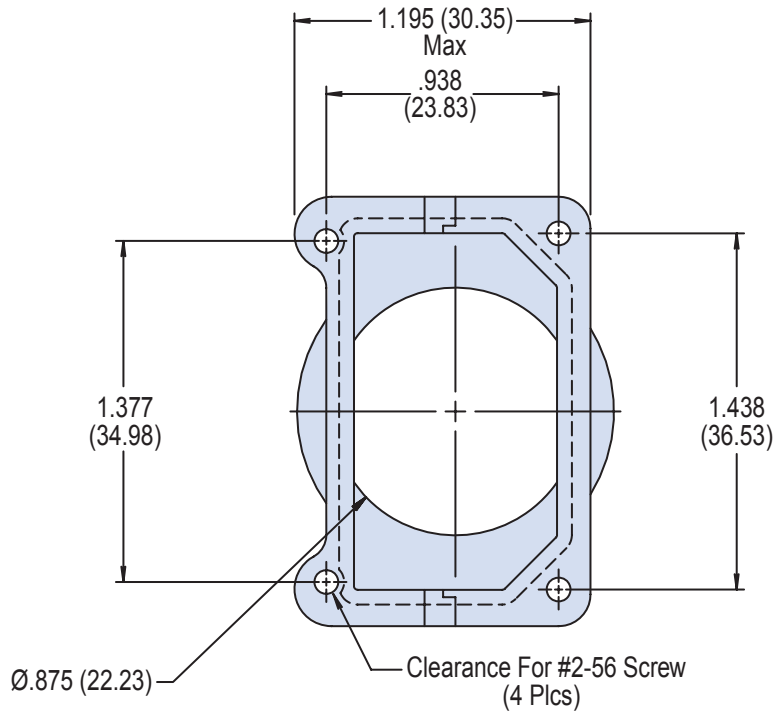
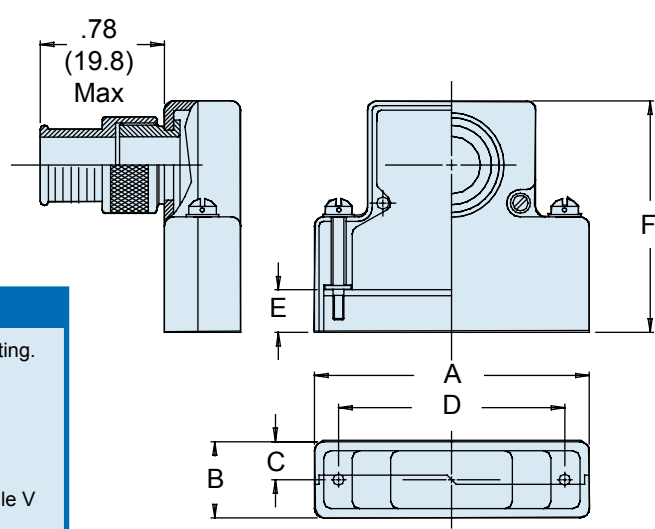
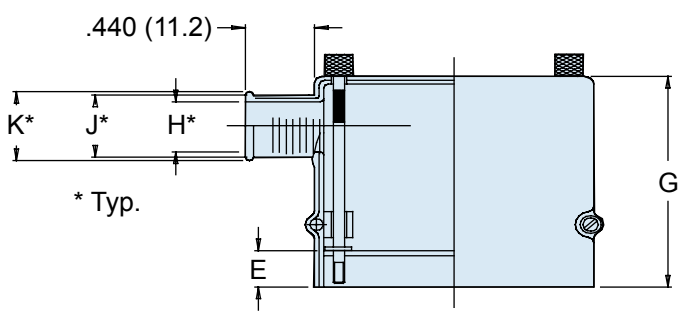
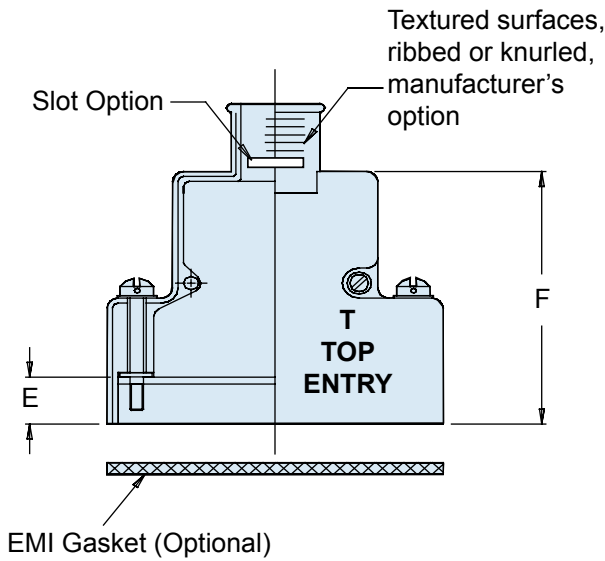
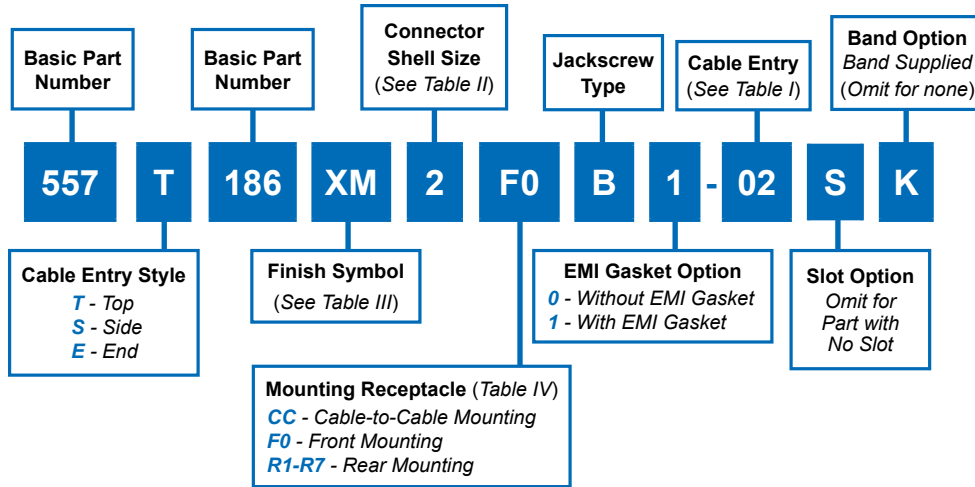


TABLE I: FINISH	
Symbol	Finish Description
XM	2000 Hour Corrosion Resistant Electroless Nickel
XO	No Plating
XMT	2000 Hour Corrosion Resistant Ni-PTFE, Nickel-Fluorocarbon Polymer. 1000 Hour Grey™
XW	2000 Hour Corrosion Resistant Cadmium/Olive Drab over Electroless Nickel

APPLICATION NOTES	
<ol style="list-style-type: none"> <li>Assembly identified with manufacturer's name and P/N, space permitting.</li> <li>Material/Finish: Backshell - High grade engineering thermoplastic/See Table I. Gasket - Metex/N.A Hardware - CRES/Passivate.</li> </ol>	<ol style="list-style-type: none"> <li>Existing insert retainer in conjunction with supplied screws.</li> <li>Metric dimensions (mm) are indicated in parentheses.</li> </ol>

A



**APPLICATION NOTES**

1. Assembly identified with manufacturer's name and P/N, space permitting.
2. Maximum entry applicable to Style T and E, Shell Size 01.  
Entry S Max -04, Styles E & T Max -05.
3. Optional slot provided for strain relief, see Table I.
4. Material/Finish:  
Adapter, Backshell - High grade engineering thermoplastic, see Table V  
Hardware - Cres Passivate  
Gasket - Metex/N.A.  
Washer - Nylon/N.A.
5. Metric dimensions (mm) in parentheses.



**557-186**  
**Composite RFI/EMI Banding Backshell**  
**for MIL-DTL-24308 D-Subminiature Connectors**



Composite Backshells

A

Symbol	Finish Description
XM	2000 Hour Corrosion Resistant Electroless Nickel
XW	2000 Hour Corrosion Resistant Cadmium/Olive Drab over Electroless Nickel
XB	No Plating—Black Base Material Non-Conductive

Dash No.	H Dia	J Dia	K Dia	X
01	.125 (3.2)	.250 (6.4)	.312 (7.9)	N/A
02	.250 (6.4)	.375 (9.5)	.438 (11.1)	.062 (1.6)
03	.312 (7.9)	.438 (11.1)	.500 (12.7)	.094 (2.4)
04	.375 (9.5)	.500 (12.7)	.562 (14.3)	.156 (4.0)
05	.438 (11.1)	.562 (14.3)	.625 (15.9)	.188 (4.8)
06	.500 (12.7)	.625 (15.9)	.688 (17.5)	.219 (5.6)
07	.562 (14.3)	.688 (17.5)	.750 (19.1)	.250 (6.4)
08	.625 (15.9)	.750 (19.1)	.812 (20.6)	.250 (6.4)
09	.750 (19.1)	.875 (22.2)	.937 (23.8)	.312 (7.9)
10	.875 (22.2)	1.000 (25.4)	1.062 (27.0)	.375 (9.5)
11	1.000 (25.4)	1.125 (28.6)	1.188 (30.2)	.375 (9.5)

Shell Size	A	B Max	C	D ±.005 (.1)	E	F	G	Max Entry (See Note 2)
1	1.378 (35.0)	.624 (15.8)	.312 (7.9)	.984 (25.0)	.340 (8.6)	1.625 (41.3)	1.750 (44.5)	04/05
2	1.691 (43.0)	.624 (15.8)	.312 (7.9)	1.312 (33.3)	.340 (8.6)	1.625 (41.3)	1.750 (44.5)	05
3	2.250 (57.2)	.624 (15.8)	.312 (7.9)	1.852 (47.0)	.343 (8.7)	1.844 (46.8)	2.000 (50.8)	05
4	2.879 (73.1)	.624 (15.8)	.312 (7.9)	2.500 (63.5)	.343 (8.7)	1.844 (46.8)	2.000 (50.8)	05
5	2.785 (70.7)	.735 (18.7)	.375 (9.5)	2.406 (61.1)	.343 (8.7)	1.844 (46.8)	2.000 (50.8)	07

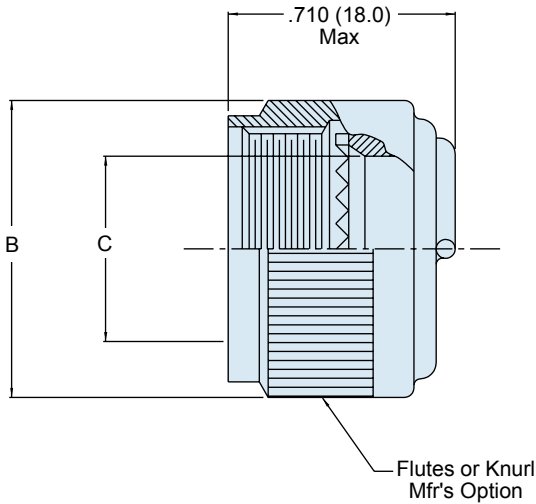
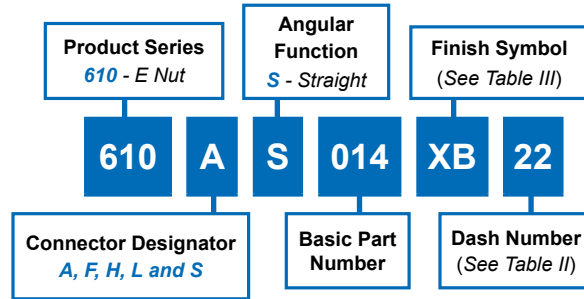
Dash No.	Panel Thickness	E	F		G	
			Sizes 1 & 2	Sizes 3 - 5	Sizes 1 & 2	Sizes 3 - 5
R1	.031 (.8)	.247 (6.3)	1.525 (38.7)	1.745 (44.3)	1.656 (42.1)	1.904 (48.4)
R2	.047 (1.2)	.231 (5.9)	1.509 (38.3)	1.728 (43.9)	1.640 (41.7)	1.888 (48.0)
R3	.062 (1.6)	.216 (5.5)	1.500 (38.1)	1.720 (43.7)	1.625 (41.3)	1.873 (47.6)
R4	.093 (2.4)	.185 (4.7)	1.470 (37.3)	1.690 (42.9)	1.594 (40.5)	1.842 (46.8)
R5	.104 (2.6)	.174 (4.4)	1.451 (36.9)	1.671 (42.4)	1.583 (40.2)	1.831 (46.5)
R6	.125 (3.2)	.153 (3.9)	1.430 (36.3)	1.650 (41.9)	1.563 (39.7)	1.811 (46.0)
R7	.156 (4.0)	.125 (3.2)	1.400 (35.6)	1.620 (41.1)	1.532 (38.9)	1.780 (45.2)

Shell Size	A	B Max	C	D ±.005 (0.1)	F	E +.030 (0.8)-.000	Max Entry (See Note 2)
1	1.363 (34.6)	.624 (15.8)	.322 (8.2)	.984 (25.0)	1.455 (37.0)	.170 (4.3)	05
2	1.691 (43.0)	.624 (15.8)	.322 (8.2)	1.312 (33.3)	1.455 (37.0)	.170 (4.3)	05
3	2.250 (57.2)	.624 (15.8)	.322 (8.2)	1.852 (47.0)	1.673 (42.5)	.172 (4.4)	05
4	2.879 (73.1)	.624 (15.8)	.322 (8.2)	2.500 (63.5)	1.673 (42.5)	.172 (4.4)	05
5	2.785 (70.7)	.735 (18.7)	.375 (9.5)	2.406 (61.1)	1.673 (42.5)	.172 (4.4)	07

# 610-014 E-Nut Backshell for Connector Designators A, F, L, S & H

A

CONNECTOR DESIGNATOR:	
<b>A</b>	MIL-DTL-5015, -26482 Series II, and -83723 Series I and III
<b>F</b>	MIL-DTL-38999 Series I, II
<b>L</b>	MIL-DTL-38999 Series 1.5 (JN1003)
<b>H</b>	MIL-DTL-38999 Series III and IV
<b>S</b>	PATT 105 / 603 / 608



NOTES	
1.	Metric dimensions (mm) are in parenthesis and are for reference only.
2.	See Table I in Intro for front-end dimensional details.

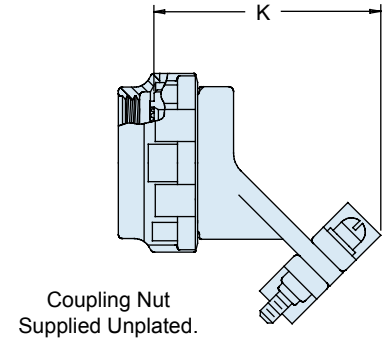
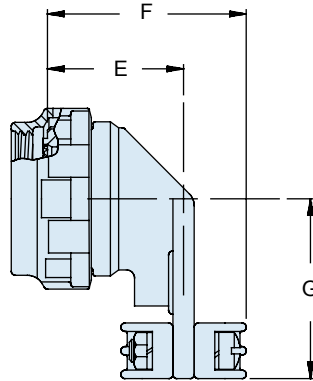
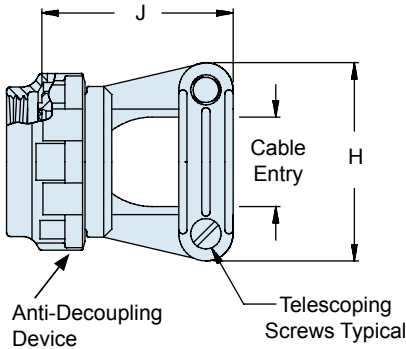
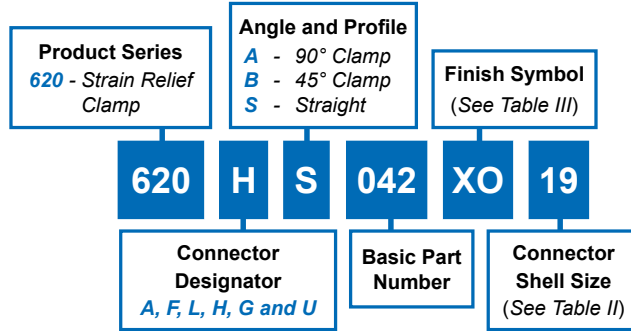
Shell Size		B Max	C Diameter Ref.
A, F, L, S	H		
03	--	.702 (17.3)	.270 (6.9)
08	09	.640 (16.3)	.270 (6.9)
10	11	.765 (19.4)	.375 (9.5)
12	13	.890 (22.6)	.511 (13.0)
14	15	1.015 (25.8)	.585 (14.9)
16	17	1.140 (29.0)	.710 (18.0)
18	19	1.265 (32.1)	.789 (20.0)
20	21	1.390 (35.3)	.914 (23.2)
22	23	1.454 (36.9)	1.039 (26.4)
24	25	1.594 (40.5)	1.154 (29.3)
61	--	1.640 (41.7)	1.194 (30.3)

Symbol	Finish Description
XB	No Plating - Black Color
XM	2000 Hour Corrosion Resistant Electroless Nickel
XMT	2000 Hour Corrosion Resistant Ni-PTFE, Nickel-Fluorocarbon Polymer. <i>1000 Hour Grey™</i>
XW	2000 Hour Corrosion Resistant Cadmium/Olive Drab over Electroless Nickel

**620-042**  
**Composite Strain-Relief Clamp**  
**with Self-Locking Rotatable Coupling**  
**Straight, 45° & 90°**



CONNECTOR DESIGNATOR:	
<b>A</b>	MIL-DTL-5015, -26482 Series II, and -83723 Series I and III
<b>F</b>	MIL-DTL-38999 Series I, II
<b>L</b>	MIL-DTL-38999 Series 1.5 (JN1003)
<b>H</b>	MIL-DTL-38999 Series III and IV
<b>G</b>	MIL-DTL-28840
<b>U</b>	DG123 and DG123A
<b>SELF-LOCKING</b>	
<b>ROTATABLE COUPLING</b>	
<b>STANDARD PROFILE</b>	



**TABLE II: CONNECTOR SHELL SIZE ORDER NUMBER**

Shell Size For Connector Designator*					E	F	G	H	J	K	Cable Entry**	
A	F/L	H	G	U	(Ref)	±.06 (1.5)	±.0 1.5	±.06 (1.5)	±.06 (1.5)	Max	±.03	0.8
08	08	09	-	-	.63 (16.0)	.86 (21.8)	.88 (22.4)	.88 (22.4)	.80 (20.3)	1.32 (33.5)	.22	(5.6)
10	10	11	-	08	.65 (16.5)	.91 (23.1)	.94 (23.9)	.94 (23.9)	.88 (22.4)	1.35 (34.3)	.26	(6.6)
12	12	13	11	10	.71 (18.0)	1.02 (25.9)	1.03 (26.2)	1.17 (29.7)	1.00 (25.4)	1.43 (36.3)	.34	(8.6)
14	14	15	13	12	.76 (19.3)	1.13 (28.7)	1.13 (28.7)	1.28 (32.5)	1.00 (25.4)	1.48 (37.6)	.46	(11.7)
16	16	17	15	14	.80 (20.3)	1.26 (32.0)	1.31 (33.3)	1.41 (35.8)	1.13 (28.7)	1.58 (40.1)	.55	(14.0)
18	18	19	17	16	.83 (21.1)	1.31 (33.3)	1.38 (35.1)	1.50 (38.1)	1.19 (30.2)	1.70 (43.2)	.62	(15.7)
20	20	21	19	18	.90 (22.9)	1.37 (34.8)	1.50 (38.1)	1.56 (39.6)	1.25 (31.8)	1.74 (44.2)	.70	(17.8)
22	22	23	-	20	.94 (23.9)	1.45 (36.8)	1.63 (41.4)	1.69 (42.9)	1.38 (35.1)	1.79 (45.5)	.78	(19.8)
24	24	25	23	22	.97 (24.6)	1.52 (38.6)	1.75 (44.5)	1.82 (46.2)	1.50 (38.1)	1.83 (46.5)	.85	(21.6)
28	-	-	25	24	1.02 (25.9)	1.68 (42.7)	1.79 (45.5)	1.94 (49.3)	1.75 (44.5)	2.13 (54.1)	.95	(24.1)

**TABLE III: FINISH**

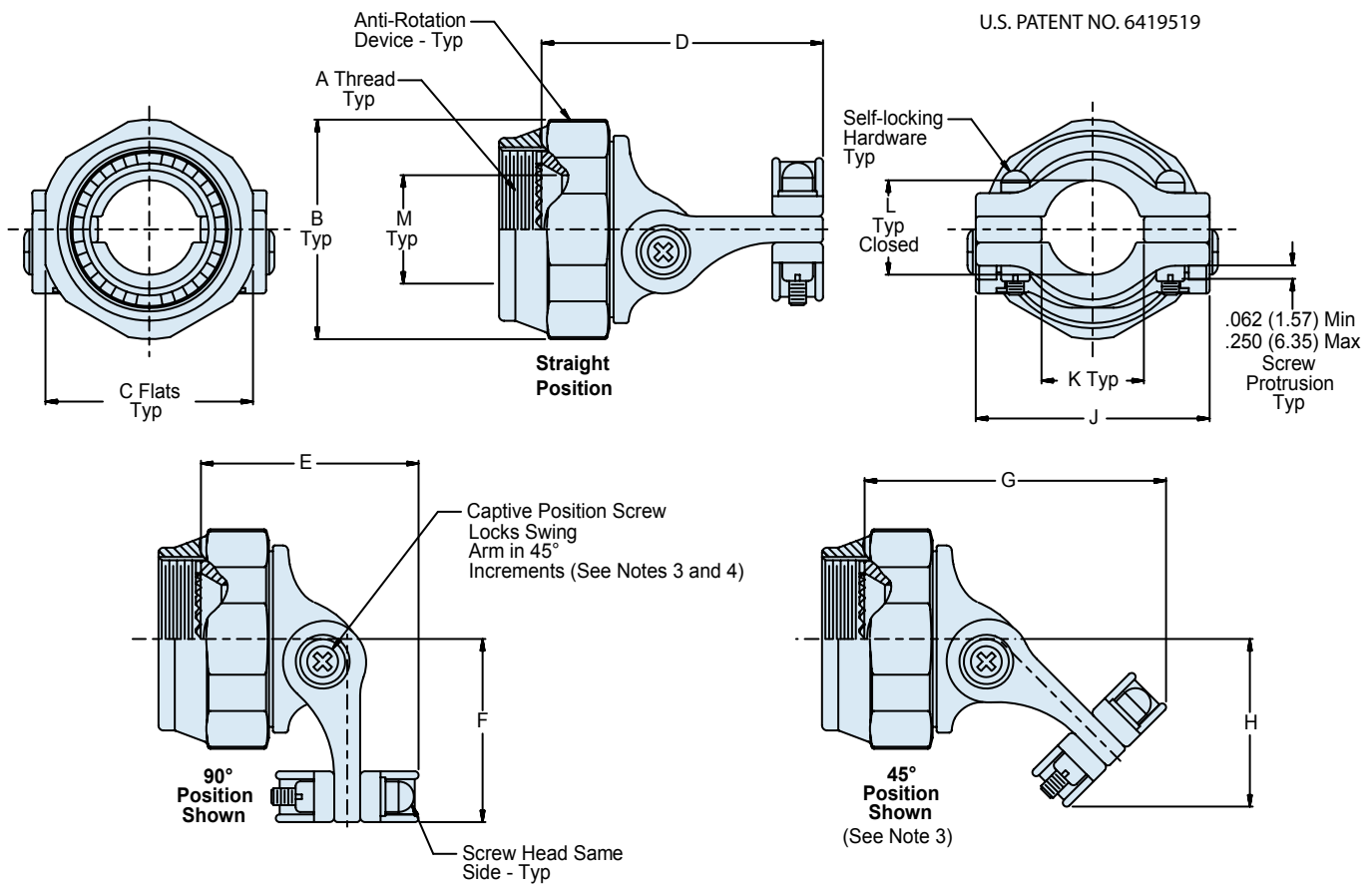
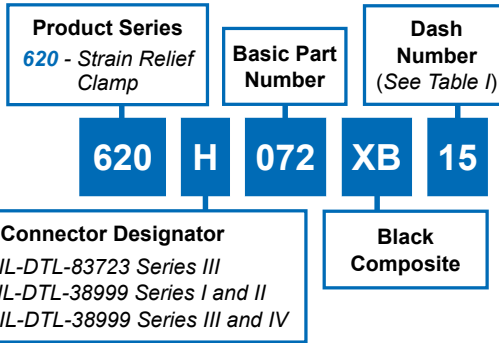
Symbol	Finish Description
XM	2000 Hour Corrosion Resistant Electroless Nickel
XO	No Plating
XMT	2000 Hour Corrosion Resistant Ni-PTFE, Nickel-Fluorocarbon Polymer. 1000 Hour Grey™
XW	2000 Hour Corrosion Resistant Cadmium/Olive Drab over Electroless Nickel



# 620-072 Composite Strain-Relief Clamp with Self-Locking Rotatable Coupling Straight, 45° & 90°

A

CONNECTOR DESIGNATOR:	
<b>A</b>	MIL-DTL-83723, Series III
<b>F</b>	MIL-DTL-38999 Series I and II
<b>H</b>	MIL-DTL-38999 Series III and IV
<b>SELF-LOCKING</b>	
<b>ROTATABLE COUPLING</b>	
<b>STANDARD PROFILE</b>	



## APPLICATION NOTES

- |  |   |
|--|---|
| <ol style="list-style-type: none"> <li>Assembly identified with manufacturer's name and P/N, space permitting.</li> <li>Glenair 600 Series backshell assembly tools are recommended for assembly and installation.</li> <li>Swing arm locks in 45° increments in sizes 09 through 25. Additional positioning increments is manufacturer's option.</li> </ol> | <ol style="list-style-type: none"> <li>Screw is captive to the arm when disengaged. When tightened, the screw shall not protrude into the inside surfaces.</li> <li>Material/Finish:<br/>Clamp body, coupling nut, saddles - High grade engineering thermoplastic, black/No plating.<br/>Clamp hardware - CRES/Passivate.<br/>Anti-Rotation device - Corrosion resistant material.</li> </ol> |
|--|---|

**620-072**  
**Composite Strain-Relief Clamp**  
**with Self-Locking Rotatable Coupling**  
**Straight, 45° & 90°**



**TABLE I: Dash Number, Shell Size Ref., Thread and Dimensions (Continued Below)**

Connector Designator A			Connector Designator F			Connector Designator H			B Max Dia	C Flats	
Dash No.	Shell Size Ref	A Thread Class 2B	Dash No.	Shell Size Ref	A Thread Class 2B	Dash No.	Shell Size Ref	A Thread ISO Metric		Max	Min
08	8	1/2-20 UNF	08	08	7/16-28 UNF	09	A	M12 x 1.0-6H	.812 (20.62)	.750 (19.05)	.736 (18.69)
10	10	5/8-24 UNEF	10	10	9/16-24 UNEF	11	B	M15 x 1.0-6H	.938 (23.83)	.875 (22.23)	.860 (21.84)
12	12	3/4-20 UNEF	12	12	11/16-24 UNEF	13	C	M18 x 1.0-6H	1.125 (28.58)	1.000 (25.40)	.980 (24.89)
14	14	7/8-20 UNEF	14	14	13/16-20 UNEF	15	D	M22 x 1.0-6H	1.250 (31.75)	1.125 (28.58)	1.000 (25.40)
16	16	1-20 UNEF	16	16	15/16-20 UNEF	17	E	M25 x 1.0-6H	1.375 (34.93)	1.250 (31.75)	1.224 (31.09)
18	18	1 1/16-18 UNEF	18	18	1 1/16-18 UNEF	19	F	M28 x 1.0-6H	1.500 (38.10)	1.375 (34.93)	1.348 (34.24)
20	20	1 3/16-18 UNEF	20	20	1 3/16-18 UNEF	21	G	M31 x 1.0-6H	1.625 (41.28)	1.500 (38.10)	1.469 (38.00)
22	22	1 5/16-18 UNEF	22	22	1 5/16-18 UNEF	23	H	M34 x 1.0-6H	1.750 (44.45)	1.625 (41.28)	1.581 (40.16)
24	24	1 7/16-18 UNEF	24	24	1 7/16-18 UNEF	25	I	M37 x 1.0-6H	1.875 (47.63)	1.750 (44.45)	1.690 (42.93)

**A**

**TABLE I: Dash Number, Shell Size Ref., Thread and Dimensions (Continued From Above)**

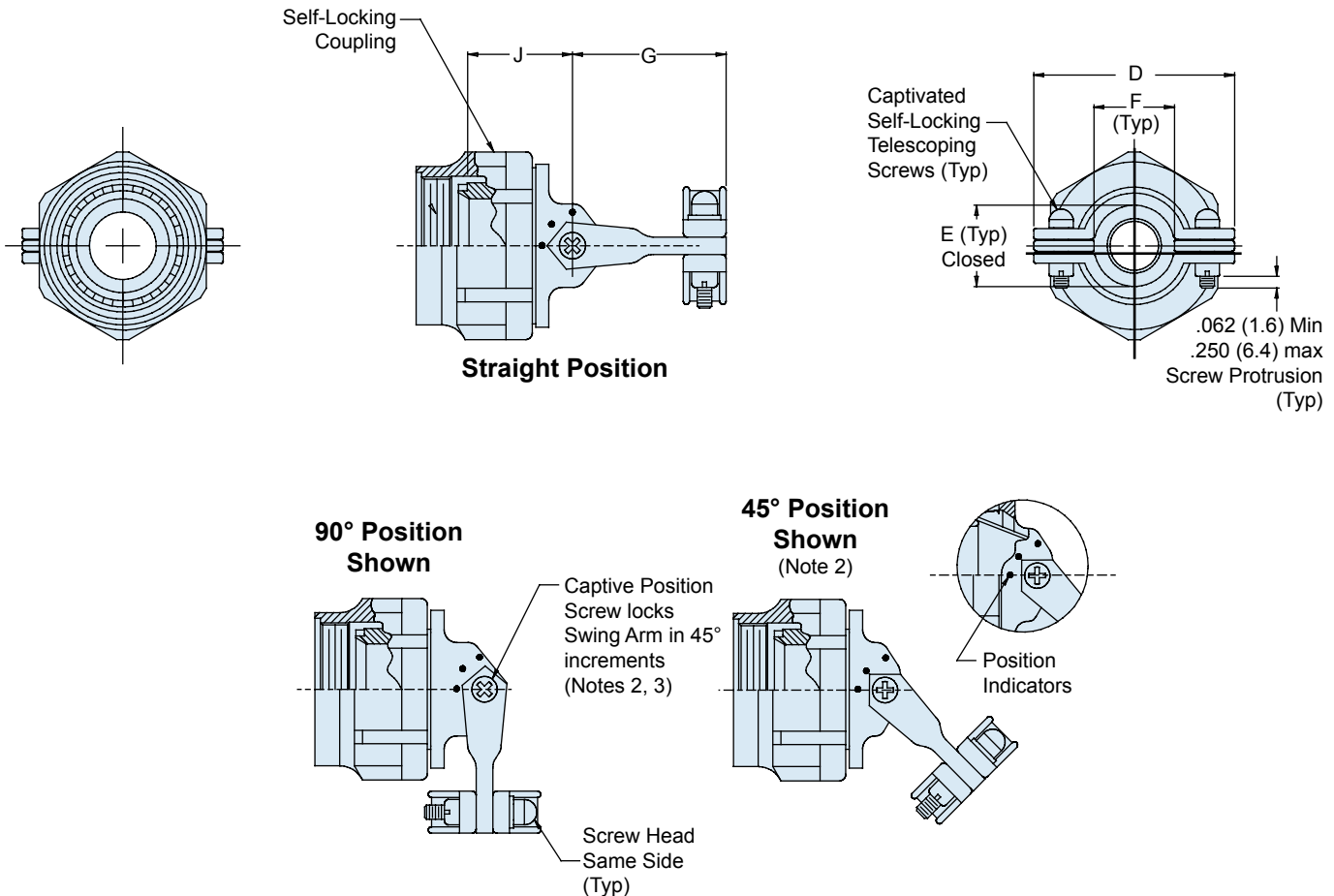
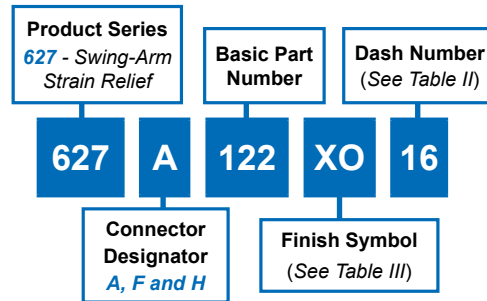
D Max	E Max	F Max	G Max	H Max	J Max	K Min	L Max	M Min
1.400 (35.56)	.850 (21.59)	.840 (21.34)	1.330 (33.78)	.760 (19.30)	.980 (24.89)	.220 (5.59)	.265 (6.73)	.264 (6.71)
1.440 (36.58)	.890 (22.61)	.900 (22.86)	1.390 (35.31)	.820 (20.83)	1.050 (26.67)	.270 (6.86)	.310 (7.87)	.390 (9.91)
1.520 (38.61)	1.040 (26.42)	1.000 (25.40)	1.540 (39.12)	.920 (23.37)	1.200 (30.48)	.350 (8.89)	.390 (9.91)	.504 (12.80)
1.530 (38.86)	1.140 (28.96)	1.070 (27.18)	1.630 (41.40)	.980 (24.89)	1.300 (33.02)	.470 (11.94)	.506 (12.85)	.630 (16.00)
1.630 (41.40)	1.260 (32.00)	1.130 (28.70)	1.760 (44.70)	1.080 (27.43)	1.440 (36.58)	.550 (13.97)	.591 (15.01)	.756 (19.20)
1.630 (41.40)	1.360 (34.54)	1.200 (30.48)	1.830 (46.48)	1.120 (28.45)	1.560 (39.62)	.620 (15.75)	.661 (16.79)	.843 (21.41)
1.780 (45.21)	1.450 (36.83)	1.260 (32.00)	1.980 (50.29)	1.210 (30.73)	1.690 (42.93)	.700 (17.78)	.744 (18.90)	.969 (24.61)
1.810 (45.97)	1.530 (38.86)	1.330 (33.78)	2.050 (52.07)	1.270 (32.26)	1.770 (44.96)	.780 (19.81)	.826 (20.98)	1.091 (27.69)
1.840 (46.74)	1.600 (40.64)	1.400 (35.56)	2.130 (54.10)	1.330 (33.78)	1.890 (48.01)	.850 (21.59)	.896 (22.76)	1.217 (30.91)

**TABLE III: FINISH**

Symbol	Finish Description
XB	No Plating - Black Color (Non-Conductive Finish)

A

CONNECTOR DESIGNATOR:	
<b>A</b>	MIL-DTL-5015, -26482 Series II, and -83723 Series I and III
<b>F</b>	MIL-DTL-38999 Series I, II
<b>H</b>	MIL-DTL-38999 Series III and IV
<b>SELF-LOCKING</b>	
<b>ROTATABLE COUPLING</b>	
<b>LOW PROFILE</b>	



U.S. PATENT NO. 6419519

# 627-122 Composite Swing-Arm Strain Relief with Self-Locking Rotatable Coupling



Composite  
Backshells

A

**TABLE II: CONNECTOR SHELL SIZE ORDER NUMBER**

Shell Size for Connector Designator*			E	F	G	H	J
A	F	H	±.06 (1.5)	Min	Max	Max	±.03 0.8
08	08	09	.265 (6.7)	.220 (5.9)	1.060 (26.9)	.980 (24.9)	.880 (22.4)
10	10	11	.310 (7.9)	.270 (6.9)	1.090 (27.7)	1.050 (26.7)	.910 (23.1)
12	12	13	.390 (9.9)	.350 (8.9)	1.180 (30.0)	1.200 (30.5)	.950 (24.1)
14	14	15	.506 (12.9)	.470 (11.9)	1.240 (31.5)	1.300 (33.0)	1.010 (25.7)
16	16	17	.591 (15.0)	.550 (14.0)	1.320 (33.5)	1.440 (36.6)	1.050 (26.7)
18	18	19	.661 (16.8)	.620 (15.7)	1.390 (35.3)	1.560 (39.6)	1.080 (30.0)
20	20	21	.744 (18.9)	.700 (17.8)	1.550 (39.4)	1.690 (42.9)	1.120 (28.4)
22	22	23	.826 (21.0)	.780 (19.8)	1.550 (39.4)	1.770 (45.0)	1.160 (29.5)
24	24	25	.896 (22.8)	.850 (21.6)	1.610 (40.9)	1.890 (48.0)	1.200 (30.5)

**TABLE III: FINISH**

Symbol	Finish Description
XB	No Plating - Black Color (Non-Conductive Finish)
XO	No Plating - Brown Color (Non-Conductive Finish)

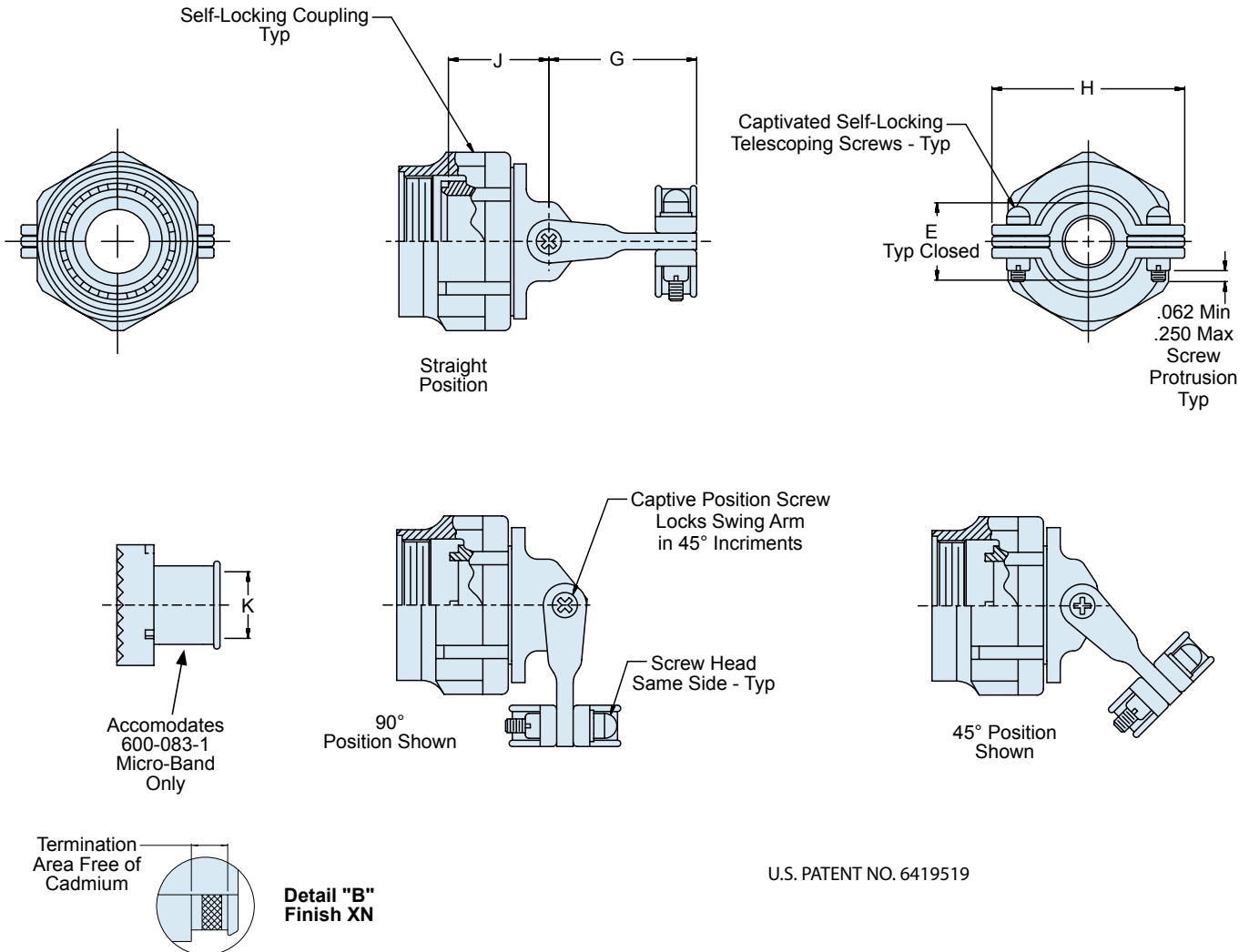
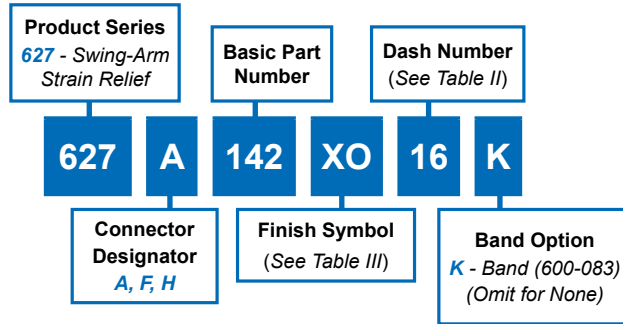
**APPLICATION NOTES**

- Metric dimensions (mm) are in parentheses and are for reference only.
- Glenair series 600 Backshell assembly Tools are recommended for assembly and installation.
- Swing Arm locks in 45° increments— Sizes 08 thru 24, additional positioning increments are manufacturer's option.
- Captive Screw can remain engaged to the body when positioning the Arm. When tightened, the Screw shall not protrude into the inside surfaces.
- Coupling nut supplied unplated.
- Consult factory for additional entry sizes available.
- See Table I in Intro for front-end dimensional details.

# 627-142 Composite Swing-Arm Strain Relief with Keyed Banding Insert and Self-Locking Coupling

A

CONNECTOR DESIGNATOR:	
<b>A</b>	MIL-DTL-5015, -26482 Series II, and -83723 Series I and III
<b>F</b>	MIL-DTL-38999 Series I, II
<b>H</b>	MIL-DTL-38999 Series III and IV
<b>SELF-LOCKING</b>	
<b>ROTATABLE COUPLING</b>	
<b>LOW PROFILE</b>	



U.S. PATENT NO. 6419519



**627-142**  
**Composite Swing-Arm Strain Relief**  
**with Keyed Banding Insert and Self-Locking Coupling**



**TABLE II: DASH NUMBER**

Shell Size		E ± .031	G Max	H Max	J ± .06	K Diameter
A, F	H					A, F and H Code
08	09	.265 (6.7)	1.06 (26.9)	.98 (24.9)	.94 (23.9)	.140 (3.6)
10	11	.312 (7.9)	1.09 (27.7)	1.05 (26.7)	.97 (24.6)	.270 (6.9)
12	13	.438 (11.1)	1.18 (30.0)	1.20 (30.5)	1.03 (26.2)	.390 (9.9)
14	15	.500 (12.7)	1.24 (31.5)	1.30 (33.0)	1.09 (27.7)	.512 (13.0)
16	17	.625 (15.9)	1.32 (33.5)	1.44 (36.6)	1.12 (28.4)	.637 (16.2)
18	19	.688 (17.5)	1.39 (35.3)	1.56 (39.6)	1.15 (29.2)	.757 (19.2)
20	21	.750 (19.1)	1.55 (39.4)	1.69 (42.9)	1.18 (30.0)	.881 (22.4)
22	23	.812 (20.6)	1.55 (39.4)	1.77 (45.0)	1.25 (31.8)	1.006 (25.6)
24	25	.938 (23.8)	1.61 (40.9)	1.89 (48.0)	1.28 (32.5)	1.131 (28.7)

**TABLE III: FINISH**

Symbol	Finish Description	Component
XB	No Plating, Black	Clamp Body, Coupling Nut, Saddles
	Electroless Nickel/Brass	Interface Ring
XMT	No Plating, Black	Clamp Body, Coupling Nut, Saddles
	Ni-PTFE, Nickel-Fluorocarbon Polymer	Interface Ring
XN	No Plating, Black	Clamp Body, Coupling Nut, Saddles
	Cadmium, Olive Drab/Brass (See Detail B)	Interface Ring

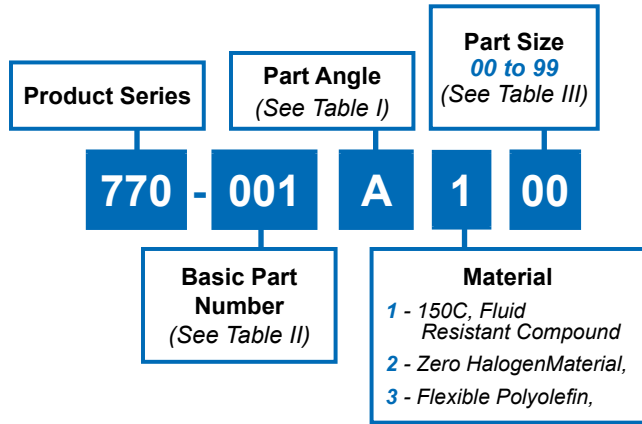
**APPLICATION NOTES**

- Metric dimensions (mm) are in parentheses and are for reference only.
- Glenair series 600 Backshell assembly Tools are recommended for assembly and installation.
- Swing Arm locks in 45° increments—Sizes 10 thru 24, additional positioning increments are manufacturer's option.
- Captive Screw can remain engaged to the body when positioning the Arm. When tightened, the Screw shall not protrude into the inside surfaces.
- Coupling nut supplied unplated.
- Consult factory for additional entry sizes available.
- See Table I in Intro for front-end dimensional details.
- K diameter may be smaller than required to accommodate fully populated connector. Consult engineering department for additional information.



**770-001**  
**Straight and 90° Shrink Boot**  
**Heat Shrink Molded Part**

**A**



**TABLE I: ANGULAR FUNCTION**

Symbol	Angle
A	90°
S	Straight

**TABLE II: BASIC PART NUMBER**

Basic No.	Description of part
001	Lipped Boot with Eyelet

**TABLE III:  
STRAIGHT, LIPPED BOOT WITH EYELET**

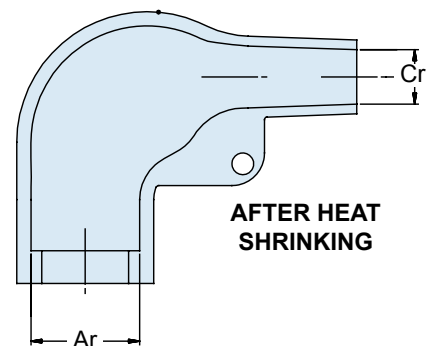
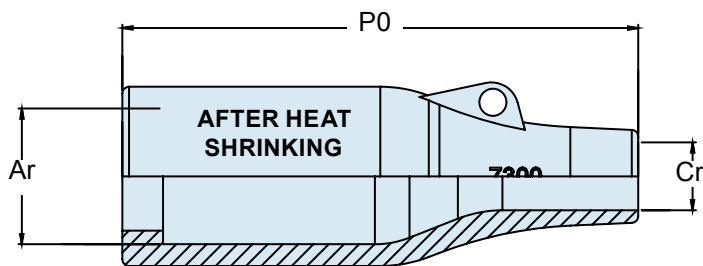
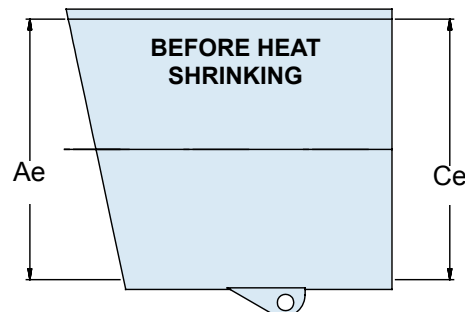
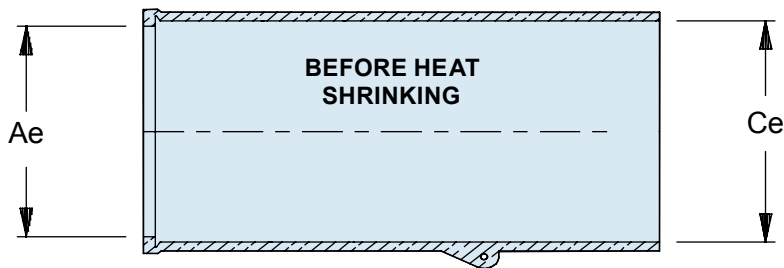
770-001 Size	Ae Min	Ar Max	Ce Min	Cr Max	P0 ± 10%
03	.94 (24)	.41 (10.5)	.94 (24)	.20 (5.0)	1.49 (38.0)
04	1.18 (30)	.55 (14)	1.18 (30)	.24 (6)	2.16 (55.0)
05	1.26 (32)	.71 (18)	1.26 (32)	.28 (7)	2.64 (67.0)
06	1.42 (36)	.87 (22)	1.42 (36)	.33 (8.5)	3.15 (80.0)
07	1.69 (43)	1.10 (28)	1.69 (43)	.39 (10)	3.90 (99.0)
08	2.36 (60)	1.37 (35)	2.36 (60)	.59 (15)	5.12 (130)

**770-001**  
**Straight and 90° Shrink Boot**  
**Heat Shrink Molded Part**



Composite Backshells

**A**



**TABLE III: 90°, LIPPED BOOT WITH EYELET**

770-001A Size	Ae Min Type 1 Mat	Ar Max Type 1 Mat	Ce Min Type 1 Mat	Cr Max Type 1 Mat
03	.94 (24)	.393 (10.0)	.94 (24)	.196 (5.0)
04	1.18 (30)	.53 (13.5)	1.18 (30)	.217 (5.5)
05	1.26 (32)	.71 (18)	1.26 (32)	.28 (7)
06	1.42 (36)	.89 (22.5)	1.42 (36)	.33 (8.5)
07	1.69 (43)	1.10 (28)	1.69 (43)	.39 (10)
08	2.36 (60)	1.37 (35)	2.36 (60)	.59 (15)

- Standard Material Fluid Resistant Cross-Linked Elastomer per VG95343 Part 6
- Low Toxicity Material Fluid Resistant Cross-Linked Elastomer per NAVSEA 5617649

**APPLICATION NOTES**

1. When the minimum number of conductors are used, wire bundle/cable may require build-up to Cr<sup>2</sup> max.
2. Sizes 00 to 02 do not contain eyelet.
3. Refer to GAP-070 for shrink boot installation guide on composite shells.

# Glenair Environmental Shrink-Boot Adapters and Series 770 Boots

Easy-to-use, semi-rigid heat-shrinkable boots offer excellent electrical, mechanical and environmental protection. Made from flame-retardant elastomeric material, these adhesive-lined boots are resistant to high temperature and chemicals. Shrink boot material is flame retardant, and the "2" option can be specified for compliance to NES smoke and toxicity requirements.

Heating the boot causes the boot to shrink while an adhesive lining bonds the boot to the connector and cable and fills small gaps for a complete seal. Choose straight cable exit or right angle exit.

Heat-shrinkable boots are ideal for environmental protection of connector wire terminations in most harsh environments including tactical military equipment. The products also supply a modicum of strain-relief.

Glenair offers a full range of sizes and shapes to accommodate mil-standard circular and rectangular connectors and backshells. Boots are also available for Series 80 Mighty Mouse connectors and accessories.



This catalog contains a wide selection of connector accessory backshells that accommodate shrink boots. These products may now be ordered with Glenair Series 770 Shrink Boots:

A Complete Range of Glenair Composite Shrink Boot Adapters	Part Number	Page
Shrink Boot Adapter with Rotatable Coupling Nut ; Straight, 45° and 90°	310-045	A-2
Shrink Boot Adapter with Direct Coupling - Straight	310-017	A-4
Lamp Base EMI/RFI Environmental Adapter with Shrink Boot Porch and Direct Coupling - Straight	311-063	A-8
EMI/RFI Banding Backshell Shield Sock with Shrink Boot Porch and Self Locking Rotatable Coupling - Straight, 45° and Ultra Low Profile 90°. Uses Micro Band to Attach Shield	319-134	A-16
TEMI/RFI Shield Sock Strain Relief with Shrink Boot Porch and Self Locking Rotatable Coupling - Straight, 45° and 90°	319-136	A-18
Knit Braid Style EMI/RFI O-Ring Equipped Shield Termination Backshell with Shrink Boot Adapter and Rotatable Coupling	380-132	A-54
EMI/RFI Micro-Banding Backshell with Shrink Boot Groove and Self Locking Rotatable Coupling - Straight, 45° and Ultra Low Profile 90°	440-144	A-70
EMI/RFI Banding Backshell with Shrink Boot Groove and Self Locking Rotatable Coupling - Standard Profile Straight, 45° and 90°	447-325	A-72
EMI/RFI Micro-Banding Backshell with Shrink Boot Groove and Self Locking Rotatable Coupling - Standard Profile Straight, 45° and 90°	447-326	A-74
EMI/RFI Banding Backshell with Qwik-Ty Strain Relief and Shrink Boot Groove - Standard Profile Straight and 90°	447-327	A-76
Shrink Boot Conduit Fitting for Glenair Series 74 Helical Convuluted Tubing	712S269	C-22

## Protect your Connector Investment with Protective Covers and Dummy Storage Receptacles

***Glenair composite protective covers reduce weight while providing reliable protection of connectors and contacts***

Glenair makes a full range of composite plug and receptacle covers for 5015, 28840, 38999 and 83723 series connectors. Protective covers are a critical component in interconnect systems where maintenance and test cycles can lead to damage of exposed connectors. Customers may select from split and solid ring designs equipped with rope, sash and bead style chains made from either nylon or stainless steel. Conductive and nonconductive

plating options are available, to match the conductivity and impedance requirements of the application and the connector. All covers meet the intermateability requirements for the specified connector series. For connector series not shown in this catalog please consult the factory. For a listing of protective covers in stock, please see our *Same Day Inventory listing* on our website at [www.glenair.com](http://www.glenair.com). Samples are always available upon request.

B

*Electrically conductive RFI/EMI covers*

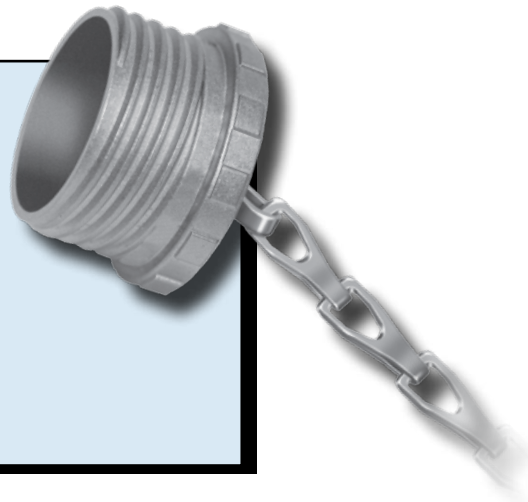
*Non-conductive versions available*

*MIL-DTL-5015, MIL-DTL-38999, MIL-DTL-28840,  
and MIL-DTL-83723 designs*

*Lower weight than comparable metal components*

*100% corrosion free materials*

*Complete range of ring styles and attachment options*



### Errata

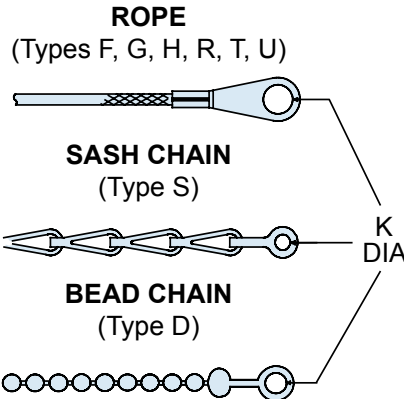
*Catalog contents—including part numbers, materials and dimensions—are accurate to the best of our ability when we go to print. Even so, customers are advised to consult the factory for the latest specifications, particularly to confirm critical dimensions such as connector interface dimensions, threads, and so on. When errors or mistakes are brought to our attention, corrected content is posted immediately to our website: [www.glenair.com](http://www.glenair.com).*

## Dimensional Tables Protective Cover Attachments

B

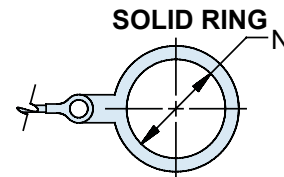
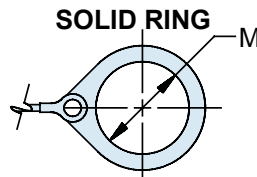
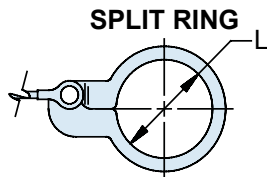
**TABLE III**

SYM	ATTACHMENT TYPE
D	Bead Chain, CRES, Passivate
F	Wire Rope, Nylon Jacket
G	Nylon Rope
H	Wire Rope, Fluoropolymer Jacket
N	No Attachment
R	Wire Rope, PVC Jacket
S	#8 Sash Chain, CRES, Passivate
T	Wire Rope, No Jacket
U	Wire Rope, Polyurethane Jacket with Terminal



**TABLE IV**

DASH NO	K DIA
	$\pm 0.10$ (0.3)
01	.140 (3.6)
02	.182 (4.6)
03	.191 (4.9)
04	.197 (5.0)
05	.167 (4.2)
06	.125 (3.2)
07	.218 (5.5)
09	.156 (4.0)



**TABLE V**

DASH NO	L DIA
	$\pm 0.15$ (0.4)
50	.425 (10.8)
52	.485 (12.3)
54	.640 (16.3)
56	.750 (19.1)
58	.890 (22.6)
60	1.015 (25.8)
62	1.095 (27.8)
64	1.130 (28.7)
66	1.250 (31.8)
68	1.350 (34.3)
70	1.390 (35.3)
72	1.485 (37.7)
74	1.625 (41.3)
76	1.750 (44.5)
78	1.875 (47.6)
80	1.980 (50.3)
82	2.060 (52.3)
84	2.235 (56.8)
86	2.310 (58.7)
88	2.475 (62.9)
90	2.655 (67.4)
92	2.810 (71.4)
94	3.045 (77.3)

**TABLE VI**

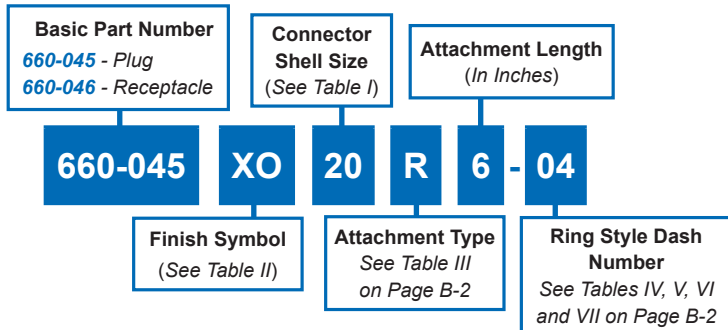
DASH NO	M DIA
	$\pm 0.15$ (0.4)
08	.468 (11.9)
10	.593 (15.1)
12	.718 (18.2)
13	.765 (19.4)
14	.844 (21.4)
15	.890 (22.6)
16	.968 (24.6)
17	1.015 (25.8)
18	1.093 (27.8)
19	1.140 (29.0)
20	1.203 (30.6)
21	1.265 (32.1)
22	1.343 (34.1)
23	1.453 (36.9)
24	1.484 (37.7)
25	1.577 (40.1)
27	1.640 (41.7)
28	1.687 (42.8)
29	1.765 (44.8)
30	1.890 (48.0)
31	1.953 (49.6)
32	1.968 (50.0)
33	2.077 (52.8)
35	2.140 (54.4)
36	2.187 (55.5)
40	2.406 (61.1)
44	2.656 (67.5)
48	3.031 (77.0)

**TABLE VII**

DASH NO	N DIA
	$\pm 0.15$ (0.4)
100	.391 (9.9)
101	.516 (13.1)
102	.583 (14.8)
103	.641 (16.3)
104	.708 (18.0)
105	.766 (19.5)
205	.788 (20.0)
106	.896 (22.2)
206	.907 (23.0)
107	1.016 (25.8)
207	1.025 (26.0)
108	1.141 (29.0)
208	1.203 (30.6)
109	1.266 (32.2)
209	1.266 (32.2)
110	1.391 (35.3)
210	1.391 (35.3)
111	1.521 (38.6)
211	1.536 (39.0)
112	1.641 (41.7)
212	1.641 (41.7)
113	1.766 (44.9)
213	1.766 (44.9)
114	1.891 (48.0)
214	1.891 (48.0)
115	2.078 (52.8)
215	2.078 (52.8)
116	2.406 (61.1)
216	2.406 (61.1)
117	2.510 (63.8)
217	2.510 (63.8)

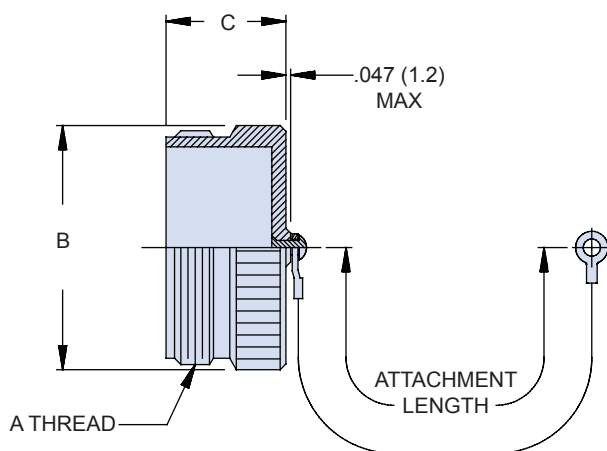
Metric dimensions (mm) are in parentheses and are for reference only.

660-045 • 660-046  
Composite MIL-DTL-5015  
Protective Covers

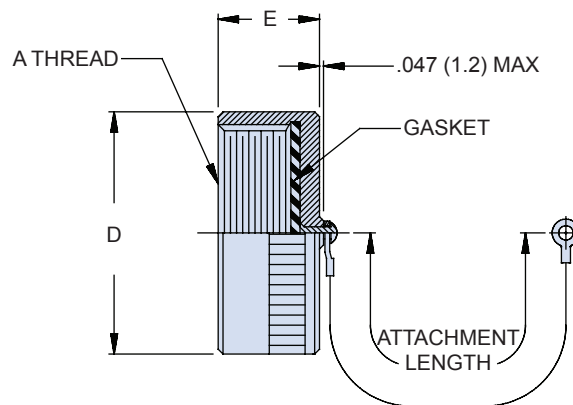


Symbol	Finish Description
XB	No Plating - Black Color (Non-Conductive Finish)
XM	2000 Hour Corrosion Resistant Electroless Nickel
XMT	2000 Hour Corrosion Resistant Ni-PTFE, Nickel-Fluorocarbon Polymer. 1000 Hour Grey™
XO	No Plating - Brown Color (Non-Conductive Finish)
XW	2000 Hour Corrosion Resistant Cadmium/Olive Drab over Electroless Nickel

660-045  
MIL-DTL-5015 PLUG COVER

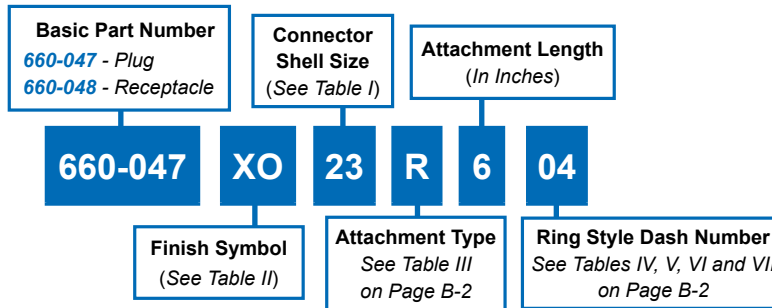


660-046  
MIL-DTL-5015 RECEPTACLE COVER



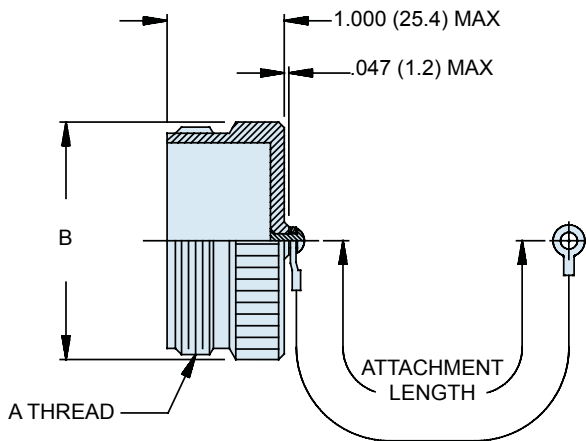
SHELL SIZE	A THREAD	B MAX	C MAX	D MAX	E MAX
08	1/2 - 28 UNEF	.562 (14.3)	.656 (16.7)	.688 (17.5)	.465 (11.8)
10	5/8 - 24 UNEF	.687 (17.4)	.656 (16.7)	.815 (20.7)	.465 (11.8)
12	3/4 - 20 UNEF	.812 (20.6)	.844 (21.4)	1.000 (25.4)	.465 (11.8)
14	7/8 - 20 UNEF	.937 (23.8)	.844 (21.4)	1.125 (28.6)	.465 (11.8)
16	1 - 20 UNEF	1.062 (27.0)	.844 (21.4)	1.188 (30.2)	.465 (11.8)
18	1 1/8 - 18 UNEF	1.187 (30.1)	.844 (21.4)	1.344 (34.1)	.465 (11.8)
20	1 1/4 - 18 UNEF	1.312 (33.3)	.844 (21.4)	1.469 (37.3)	.465 (11.8)
22	1 3/8 - 18 UNEF	1.437 (36.5)	.844 (21.4)	1.594 (40.5)	.465 (11.8)
24	1 1/2 - 18 UNEF	1.562 (39.7)	.844 (21.4)	1.719 (43.7)	.465 (11.8)
28	1 3/4 - 18 UNS	1.812 (46.0)	.844 (21.4)	1.969 (50.0)	.531 (13.5)
32	2 - 18 UNS	2.062 (52.4)	.844 (21.4)	2.219 (56.4)	.531 (13.5)
36	2 1/4 - 16 UN	2.312 (58.7)	.844 (21.4)	2.469 (62.7)	.531 (13.5)
40	2 1/2 - 16 UN	2.562 (65.1)	.844 (21.4)	2.719 (69.1)	.531 (13.5)
44	2 3/4 - 16 UN	2.812 (71.4)	.844 (21.4)	2.969 (75.4)	.531 (13.5)
48	3 - 16 UN	3.062 (77.8)	.844 (21.4)	3.188 (81.0)	.531 (13.5)

Metric dimensions (mm) are in parentheses and are for reference only.

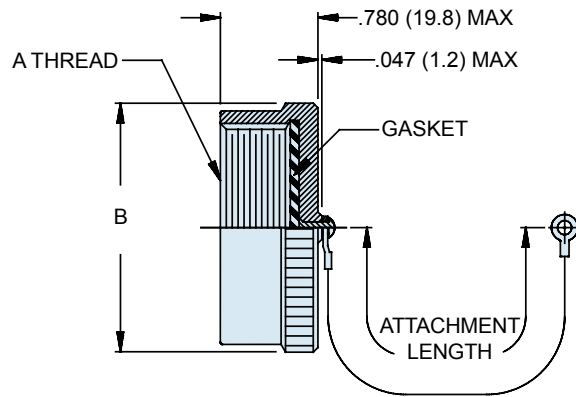


B

**660-047  
MIL-DTL-28840 PLUG COVER**



**660-048  
MIL-DTL-28840 RECEPTACLE COVER**



**TABLE I: CONNECTOR SHELL SIZE ORDER NUMBER**

DESIGNATOR (REF)	SHELL SIZE	A THREAD	B MAX	
			In	mm
A	11	.750 -.1P-.2L-DS	1.028	(26.1)
B	13	.875 -.1P-.2L-DS	1.141	(29.0)
C	15	1.062 -.1P-.2L-DS	1.263	(32.1)
D	17	1.125 -.1P-.2L-DS	1.387	(35.2)
E	19	1.312 -.1P-.2L-DS	1.513	(38.4)
F	23	1.500 -.1P-.2L-DS	1.703	(43.5)
G	25	1.625 -.1P-.2L-DS	1.825	(46.4)
H	29	1.812 -.1P-.2L-DS	2.143	(54.4)
J	33	2.000 -.1P-.2L-DS	2.329	(59.2)

**TABLE II**

Symbol	Finish Description
XB	No Plating - Black Color (Non-Conductive Finish)
XM	2000 Hour Corrosion Resistant Electroless Nickel
XMT	2000 Hour Corrosion Resistant Ni-PTFE, Nickel-Fluorocarbon Polymer. 1000 Hour Grey™
XO	No Plating - Brown Color (Non-Conductive Finish)
XW	2000 Hour Corrosion Resistant Cadmium/Olive Drab over Electroless Nickel

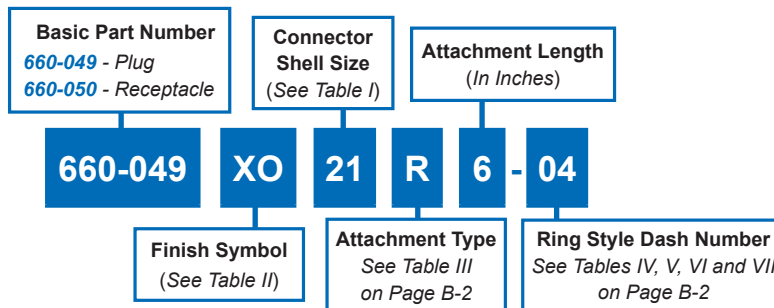
Metric dimensions (mm) are in parentheses and are for reference only.



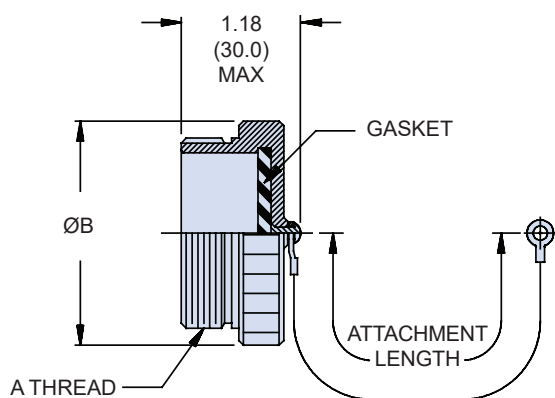
660-049 • 660-050  
Composite MIL-DTL-38999 Series III  
Protective Covers



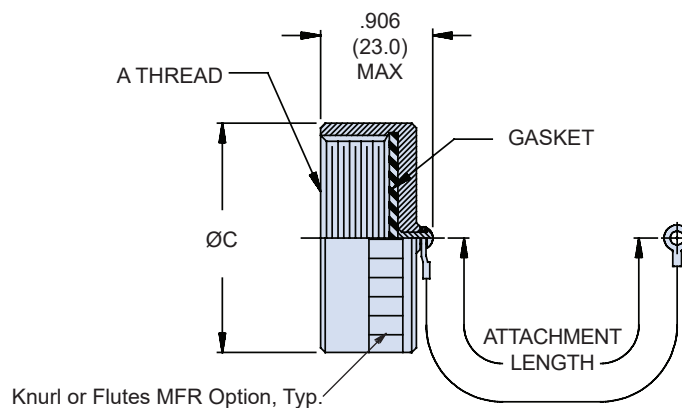
Protective  
Covers



**660-049**  
**MIL-DTL-38999/32**  
**PLUG COVER**



**660-050**  
**MIL-DTL-38999/33**  
**RECEPTACLE COVER**



**TABLE I: CONNECTOR SHELL SIZE ORDER NUMBER**

SHELL SIZE	A THREAD	B DIA MAX	C DIA MAX
09	.6250 -0.1P-0.3L-TS	.906 (23.0)	.906 (23.0)
11	.7500 -0.1P-0.3L-TS	1.024 (26.0)	1.102 (28.0)
13	.8750 -0.1P-0.3L-TS	1.220 (31.0)	1.220 (31.0)
15	1.0000 -0.1P-0.3L-TS	1.300 (33.0)	1.260 (32.0)
17	1.1875 -0.1P-0.3L-TS	1.457 (37.0)	1.457 (37.0)
19	1.2500 -0.1P-0.3L-TS	1.575 (40.0)	1.535 (39.0)
21	1.3750 -0.1P-0.3L-TS	1.732 (44.0)	1.654 (42.0)
23	1.5000 -0.1P-0.3L-TS	1.811 (46.0)	1.772 (45.0)
25	1.6250 -0.1P-0.3L-TS	1.969 (50.0)	1.929 (49.0)

**Table II: Finish**

Code	Finish Description
XM	1000 Hr. Corrosion-Resistant Electroless Nickel
XW	1000 Hr. Corrosion-Resistant Cadmium Olive Drab over Electroless Nickel
XB	No Plating - Black Color
XV	No Plating - Purple Color

Metric dimensions (mm) are in parentheses and are for reference only.

B



660-077 • 660-078  
**Glenair Composite 190 Series**  
 Protective Covers

**B**

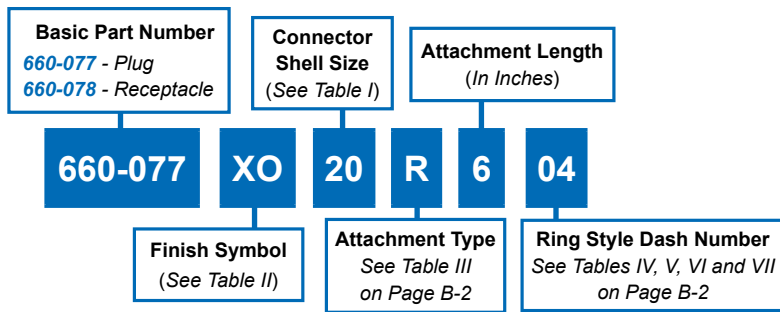


TABLE II	
Symbol	Finish Description
XB	No Plating - Black Color (Non-Conductive Finish)
XM	2000 Hour Corrosion Resistant Electroless Nickel
XMT	2000 Hour Corrosion Resistant Ni-PTFE, Nickel-Fluorocarbon Polymer. 1000 Hour Grey™
XO	No Plating - Brown Color (Non-Conductive Finish)
XW	2000 Hour Corrosion Resistant Cadmium/Olive Drab over Electroless Nickel

**660-077**  
**Glenair 190-015 PLUG COVER**

**660-078**  
**Glenair 190-016 RECEPTACLE COVER**

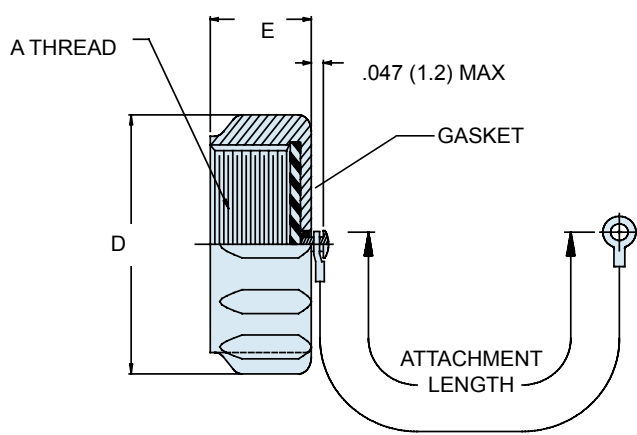
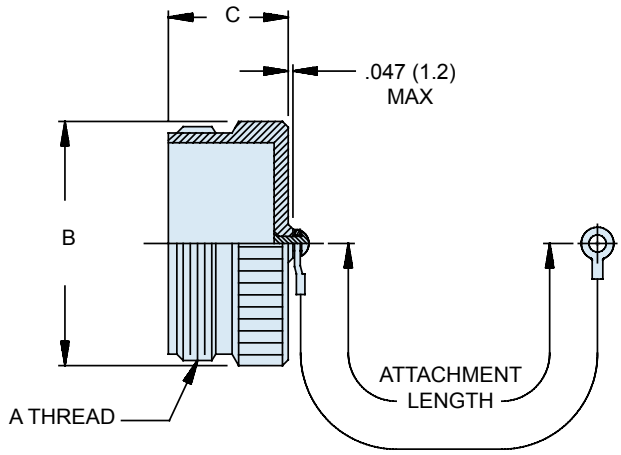
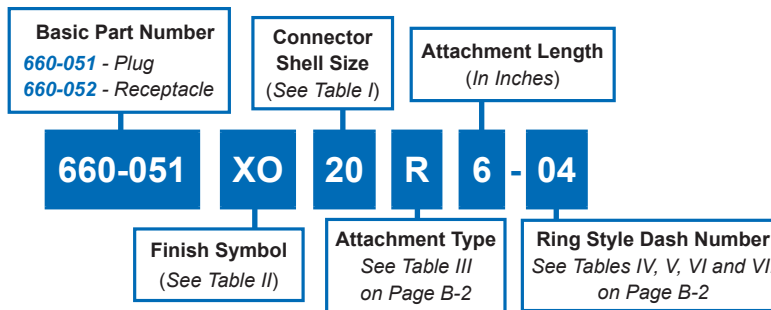


TABLE I: CONNECTOR SHELL SIZE ORDER NUMBER					
SHELL SIZE	A THREAD	B MAX	C MAX	D MAX	E MAX
10SL	.625 - .1P-1L	1.125 (28.6)	1.093 (27.8)	1.156 (29.4)	.750 (19.1)
14S	.875 - .1P-1L	1.312 (33.3)	1.093 (27.8)	1.343 (34.1)	.719 (18.3)
18	1.125 - .1P-1L	1.565 (39.8)	1.093 (27.8)	1.596 (40.5)	.975 (24.8)

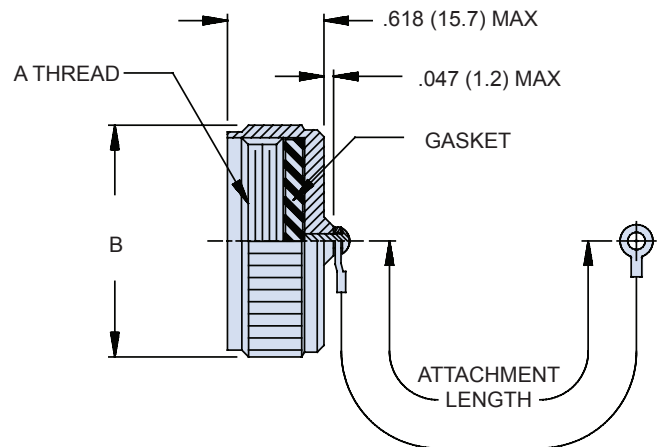
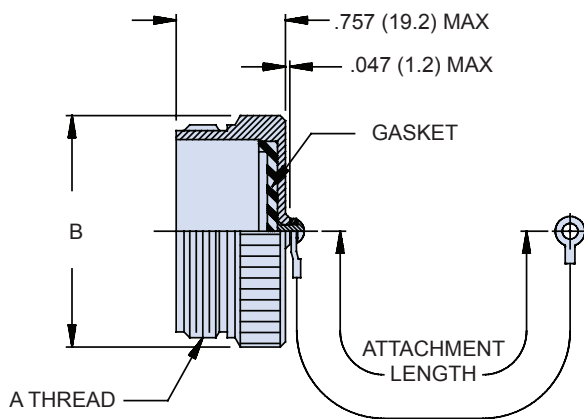
Metric dimensions (mm) are in parentheses and are for reference only.

660-051 • 660-052  
Composite MIL-DTL-83723 Series III  
Protective Covers



660-051  
MIL-DTL-83723 SERIES III  
THREADED PLUG COVER

660-052  
MIL-DTL-83723 SERIES III  
THREADED RECEPTACLE COVER



**TABLE I: CONNECTOR SHELL SIZE NO.**

SHELL SIZE	A THREAD CLASS 2A/2B	B DIA MAX
08	9/16 - 24 UNEF	.776 (19.7)
10	11/16 - 24 UNEF	.906 (23.0)
12	7/8 - 20 UNEF	1.078 (27.4)
14	15/16 - 20 UNEF	1.141 (29.0)
16	1 1/16 - 18 UNEF	1.266 (32.2)
18	1 3/16 - 18 UNEF	1.375 (34.9)
20	1 5/16 - 18 UNEF	1.510 (38.4)
22	1 7/16 - 18 UNEF	1.625 (41.3)
24	1 9/16 - 18 UNEF	1.760 (44.7)

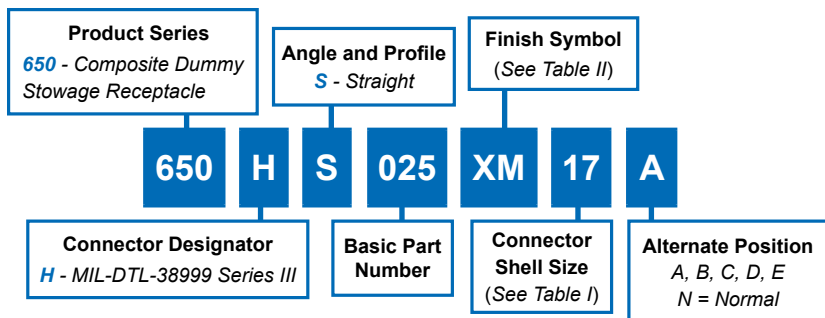
**TABLE II**

Symbol	Finish Description
XB	No Plating - Black Color (Non-Conductive Finish)
XM	2000 Hour Corrosion Resistant Electroless Nickel
XMT	2000 Hour Corrosion Resistant Ni-PTFE, Nickel-Fluorocarbon Polymer. 1000 Hour Grey™
XO	No Plating - Brown Color (Non-Conductive Finish)
XW	2000 Hour Corrosion Resistant Cadmium/Olive Drab over Electroless Nickel

Metric dimensions (mm) are in parentheses and are for reference only.

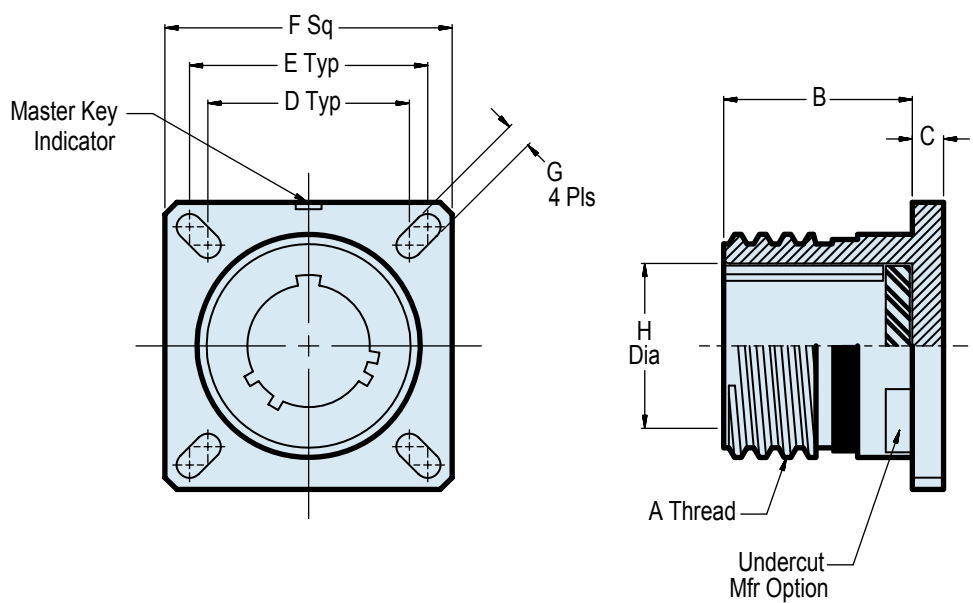


# 650-025 Composite Dummy Stowage Receptacle for MIL-DTL-38999 Series III Connectors



Symbol	Finish Description
<b>XB</b>	No Plating - Black Color (Non-Conductive Finish)
<b>XM</b>	1000 Hour Corrosion Resistant Electroless Nickel
<b>XW</b>	1000 Hour Corrosion Resistant Cadmium/Olive Drab over Electroless Nickel
<b>XO</b>	No Plating - Brown Color (Non-Conductive Finish)
<b>XMT</b>	Metalize in Electrodeposited Copper Flash Per MIL-C-14550, Nickel-PTFE IAW GP552-XMT

**B**



Shell Size	Shell Size Code	A Thread	B +.055 (1.4) -0.00	C	D	E	F ±.012 (0.3)	G Dim ±.008 (0.20)	H +.000 -.005 (.127)
09	A	.625-.1P-0.3LTS	.786 (19.5)	.144/.087 (3.65/2.2)	.594 (15.1)	.719 (18.3)	.937 (23.8)	.128 (3.3)	.192 (12.5)
11	B	.750-.1P-0.3LTS	.786 (19.5)	.144/.087 (3.65/2.2)	.719 (18.3)	.812 (20.6)	1.031 (26.2)	.128 (3.3)	.620 (15.7)
13	C	.875-.1P-0.3LTS	.786 (19.5)	.144/.087 (3.65/2.2)	.812 (20.6)	.906 (23.0)	1.126 (28.6)	.128 (3.3)	.769 (19.5)
15	D	1.000-.1P-0.3LTS	.786 (19.5)	.144/.087 (3.65/2.2)	.906 (23.0)	.969 (24.6)	1.220 (31.0)	.128 (3.3)	.894 (22.7)
17	E	1.187-.1P-0.3LTS	.786 (19.5)	.144/.087 (3.65/2.2)	.969 (24.6)	1.062 (27.0)	1.311 (33.3)	.128 (3.3)	1.019 (25.9)
19	F	1.250-.1P-0.3LTS	.786 (19.5)	.144/.087 (3.65/2.2)	1.062 (27.0)	1.156 (29.4)	1.437 (36.5)	.128 (3.3)	1.124 (28.5)
21	G	1.375-.1P-0.3LTS	.736 (18.7)	.171/.114 (4.35/9)	1.156 (29.4)	1.250 (31.8)	1.563 (39.7)	.128 (3.3)	1.249 (31.7)
23	H	1.500-.1P-0.3LTS	.736 (18.7)	.171/.114 (4.35/9)	1.250 (31.8)	1.375 (34.9)	1.689 (42.9)	.154 (3.9)	1.374 (34.9)
25	J	1.625-.1P-0.3LTS	.736 (18.7)	.171/.114 (4.35/9)	1.375 (34.9)	1.500 (38.1)	1.811 (46.0)	.154 (3.9)	1.499 (38.1)

Metric dimensions (mm) are in parentheses and are for reference only.

# 660-121

## Composite Receptacle Cover for MIL-DTL-38999 Series III Connectors with Anti-Decoupling Device



Protective Covers

Part Number Development											
Sample Part Number	<b>660-121</b>					<b>XB</b>	<b>19</b>	<b>R</b>	<b>6</b>	<b>-01</b>	<b>G</b>
<b>Product Series-Basic No.</b>	Self locking receptacle cover										
<b>Finish</b>	XW, XB, XM, XMT; See material/finish table										
<b>Shell Size</b>	09, 11, 13, 15, 17, 19, 21, 23, 25; see dimensions table										
<b>Attachment Type</b>	F, G, H, K, N, R, T; See attachment code table										
<b>Attachment Length</b>	Inches; i.e. 01 = 1 inch										
<b>Ring Style Dash No.</b>	See ring style tables A, B, C or D										
<b>Grounding</b>	G = Ground Spring; Omit for none										

Material/Finish	
Sym	Material / Finish Description
XW	Cad/O.D. over electroless nickel (1000 hr)
XB	Black color-no plating
XM	Electroless nickel (1000 hr)
XMT	Ni-PTFE (1000 hr grey)

Dimensions		
Shell Size	A Thread 0.1P-0.3L-TS	Ø B Max
09	.6250	.858 (21.8)
11	.7500	.984 (25.0)
13	.8750	1.157 (29.4)
15	1.0000	1.279 (32.49)
17	1.1875	1.405 (35.69)
19	1.2500	1.515 (38.48)
21	1.3750	1.641 (41.68)
23	1.5000	1.767 (44.88)
25	1.6250	1.889 (47.98)

Attachment Codes	
Code	Description
F	Wire Rope, Nylon Jacket with terminal
G	Nylon Rope, Black, with looped end
H	Wire Rope, Fluoropolymer Jacket with terminal
K	Nylon Rope, Olive Drab
N	No attachment
R	Wire Rope, PVC Jacket with attachment
T	Wire Rope, No Jacket with attachment

### NOTES

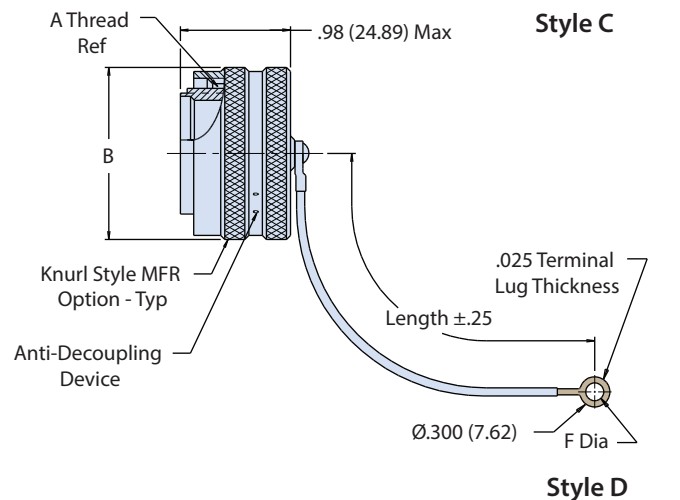
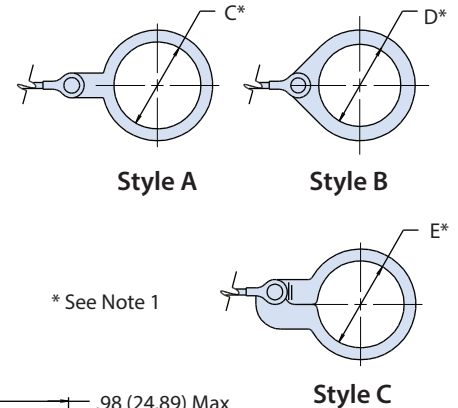
- Max diameter over which mandrel will rotate freely

Ring Style A	
Dash No	C Dia
100	.391 (9.93)
101	.516 (13.11)
102	.583 (14.81)
103	.641 (16.28)
104	.708 (17.98)
105	.766 (19.46)
106	.896 (22.76)
107	1.016 (25.81)
108	1.141 (28.98)
109	1.266 (32.16)
110	1.391 (35.33)
111	1.521 (38.63)
112	1.641 (41.68)
113	1.766 (44.86)
114	1.891 (48.03)
115	2.078 (52.78)
116	2.406 (61.11)
117	2.510 (63.75)
206	.907 (23.04)
208	1.203 (30.56)

Ring Style B	
Dash No	D Dia
08	.468 (11.89)
10	.593 (15.06)
12	.718 (18.24)
14	.844 (21.44)
16	.968 (24.59)
18	1.093 (27.76)
20	1.187 (30.15)
22	1.343 (34.11)
24	1.484 (37.69)
28	1.687 (42.85)
32	1.968 (49.99)
36	2.187 (55.55)
40	2.406 (61.11)
44	2.656 (67.46)
48	3.031 (76.99)

Ring Style C	
Dash No	E Dia
50	.425 (10.80)
52	.485 (12.32)
54	.640 (16.26)
56	.750 (19.05)
58	.890 (22.61)
60	1.015 (25.78)
62	1.095 (27.81)
64	1.130 (28.70)
66	1.250 (31.75)
68	1.350 (34.29)
70	1.3475 (34.23)
72	1.485 (37.72)
74	1.625 (41.28)
76	1.750 (44.45)
78	1.875 (47.63)
80	1.980 (50.29)
82	2.060 (52.32)
84	2.235 (56.77)
86	2.310 (58.67)
88	2.475 (62.87)
90	2.655 (67.44)
92	2.810 (71.37)
94	3.045 (77.34)

Ring Style D	
Dash No	F Dia
01	.140 (3.56)
02	.182 (4.62)
03	.191 (4.85)
04	.197 (5.00)
05	.167 (4.24)
06	.125 (3.18)



# 667-118 Composite Receptacle Cover for MIL-DTL-5015 Series Connectors with Anti-Decoupling Device

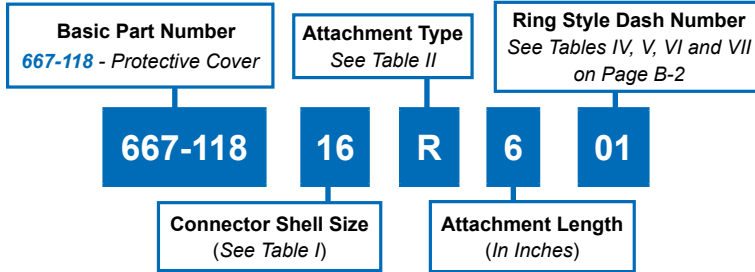


TABLE II	
Symbol	Finish Description
XB	No Plating - Black Color (Non-Conductive Finish)
XM	2000 Hour Corrosion Resistant Electroless Nickel
XMT	2000 Hour Corrosion Resistant Ni-PTFE, Nickel-Fluorocarbon Polymer. 1000 Hour Grey™
XO	No Plating - Brown Color (Non-Conductive Finish)
XW	2000 Hour Corrosion Resistant Cadmium/Olive Drab over Electroless Nickel

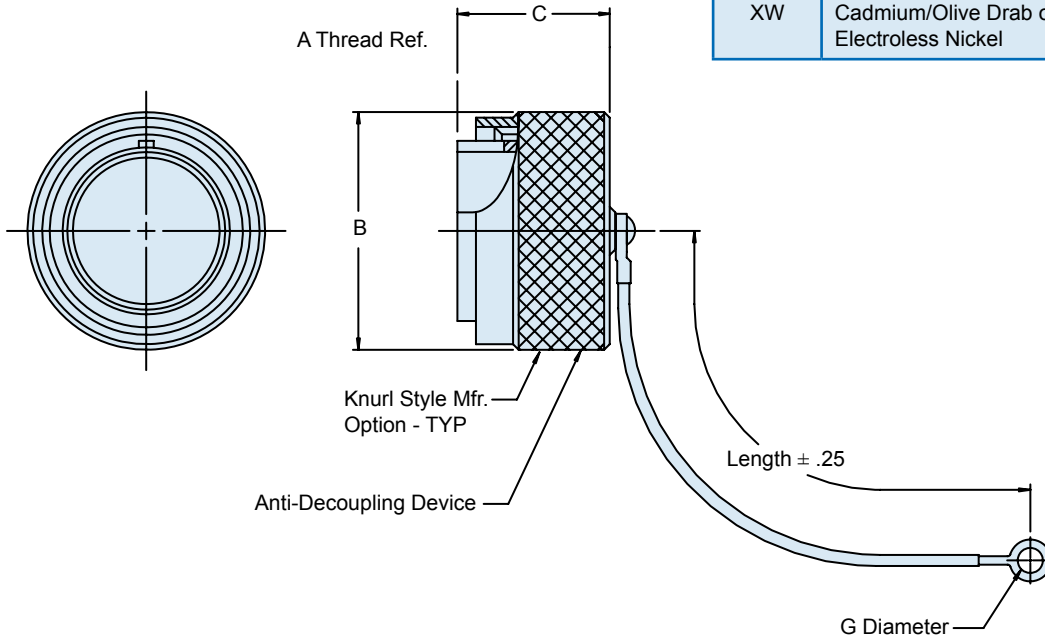


TABLE I: CONNECTOR SHELL SIZE

Shell Size	A Thread	B Max	C Max
08	1/2-28	.844	1.13
10	5/8-24	.969	
12	3/4-20	1.062	
14	7/8-20	1.156	
16	1-20	1.250	
18	1 1/8-18	1.344	
20	1 1/4-18	1.469	
22	1 3/8-18	1.549	
24	1 1/2-18	1.719	
28	1 3/4-18	1.969	

TABLE II: ATTACHMENT

Symbol	Attachment
F	Wire Rope, Nylon Jacket w/ Terminal
G	.094 Diameter Nylon Cord (black) w/ Loop Ends
H	Wire Rope, Teflon Jacket w/ Terminal
N	Attachment Omitted
R	Wire Rope, PVC Jacket w/ Terminal
T	Wire Rope, NO Jacket, w/ Terminal
K	Nylon Rope

Metric dimensions (mm) are in parentheses and are for reference only.

# Custom Conduit Assemblies

## Wired, Terminated and Tested—Ready for Use

Glenair's complete capability in wire protection systems extends to the design, manufacture and test of custom conduit assemblies—built to your exact specifications. Our turn-key service includes everything from engineering and design assistance to the on-time delivery of completely wired, terminated and tested assemblies—ready for immediate use.

Glenair's has established an enviable reputation for consistently high quality. Regardless of simplicity or complexity, or whether quantities are large or small, the same high standards of quality assurance are applied uniformly. Our ISO 9001:2000 and AS9100:2004 Rev B certified quality system and strict adherence to military and commercial testing standards ensures each conduit assembly is thoroughly inspected at each stage of the process. Each system undergoes a final inspection process which includes appearance, identification, dielectric, continuity, and insulation tests

conducted on a 100% basis in preparation for final customer source inspection.

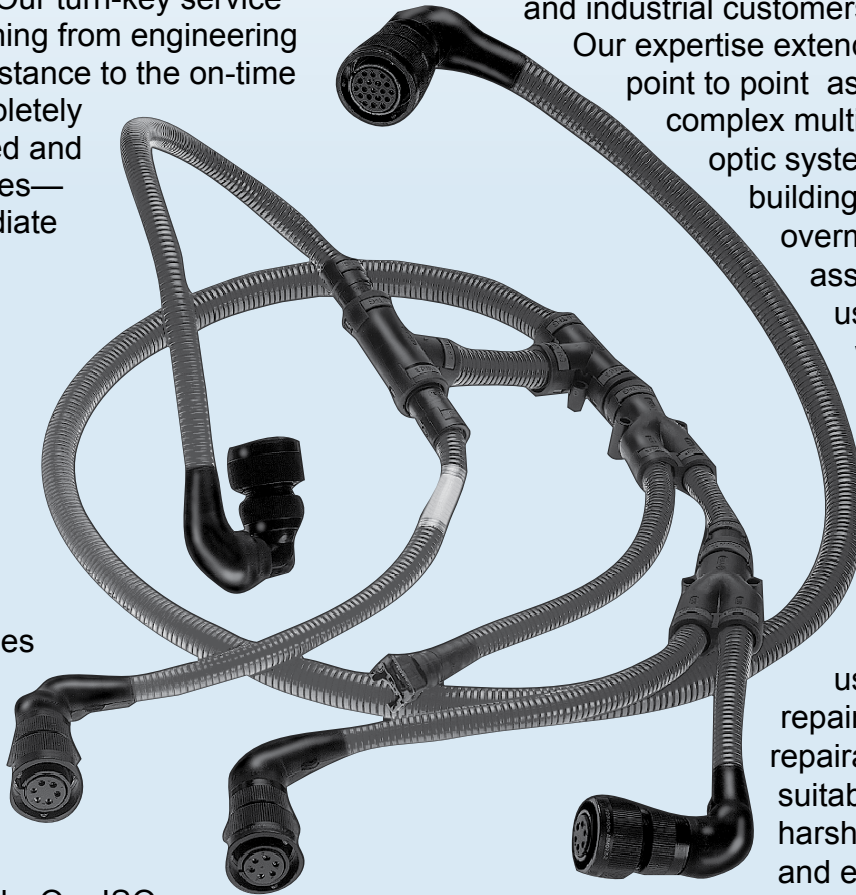
Glenair has built electrical, optical and hybrid assemblies for military, commercial and industrial customers since the 1950's.

Our expertise extends from simple point to point assemblies to complex multi-branch and fiber optic systems. Today, we're building everything from overmolded fiber optic assemblies for marine use, to wheel-well assemblies for the world's leading aircraft manufacturers.

Our in-house braiding and sleeving capabilities allow us to build both repairable and non-repairable assemblies suitable for use in harsh electromagnetic and environmental conditions. We offer a

complete range of jacketing, shielding and braided protective covering options including NBC (nuclear, biological, chemical) materials.

From one-of-a-kind conduit systems, to high volume mass production requirements, Glenair delivers with consistent quality, on-time delivery and reliable customer service.



1211 Air Way · Glendale, California 91201-2497

Telephone: 818-247-6000 · Facsimile: 818-500-9912 · E-mail: sales@glenair.com

United States · United Kingdom · Germany · Nordic · France · Italy · Spain · Japan

www.glenair.com

## Convulsed Tubing Wire Protection Systems: Where Flexibility and Field Repairability Meet.

### *Advanced EMI Shielded Wire Protection Systems for Shipboard, Aerospace, Electric Vehicle and Heavy Equipment Applications*

Glenair's Series 74 Helical Convulsed Tubing Systems provide outstanding wire circuit and cable protection for applications that require advanced durability and flexibility compared to standard jacketed cables. The series 74 system features a broad selection of transition fittings and adapters for easy routing and incorporation of industry-standard connectors. Our PEEK™ and Fluoropolymer polymers result in extremely rugged, lightweight enclosures for wiring systems deployed in harsh environment applications. Turnkey wired assemblies can be equipped with a broad range of fittings, jacketing and screening materials.

*Convulsed Tubing Service Temperature Ranges of -95°F to +500°F Long Term, +600°F Short Term*

*Tensile Strength Ratings to 7,000 PSI*

*Resistance to Hydraulic Fluids, Fuels, Lubricating Oils,  
Solvents and Decontaminating Agents*

*Lightweight, Halogen-Free*

*Crush-Resistant*

*High-Temperature*

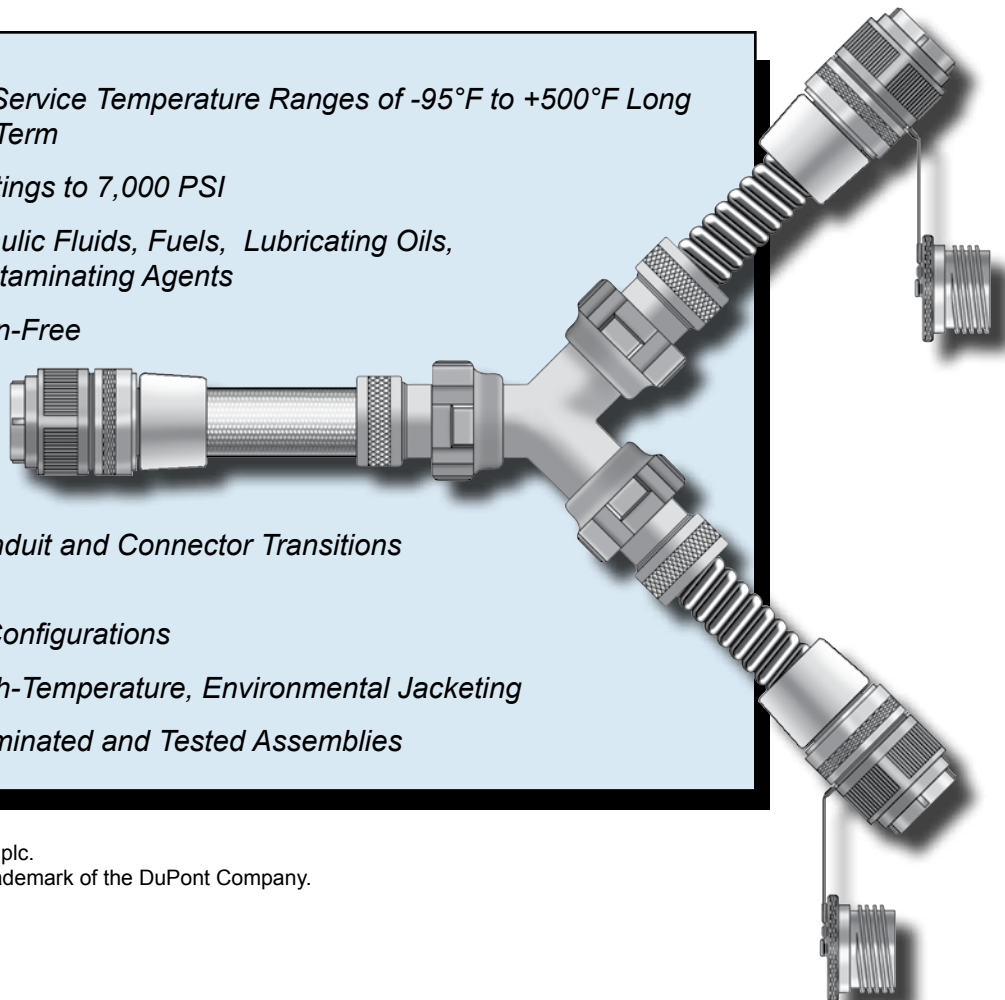
*Maximum Flexibility*

*Broad Range of Conduit and Connector Transitions  
and Fittings*

*EMI/RFI Shielding Configurations*

*Broad Range of High-Temperature, Environmental Jacketing*

*Turnkey, Wired, Terminated and Tested Assemblies*



PEEK™ is a trademark of Vitrex plc.  
Fluoropolymer is a registered trademark of the DuPont Company.



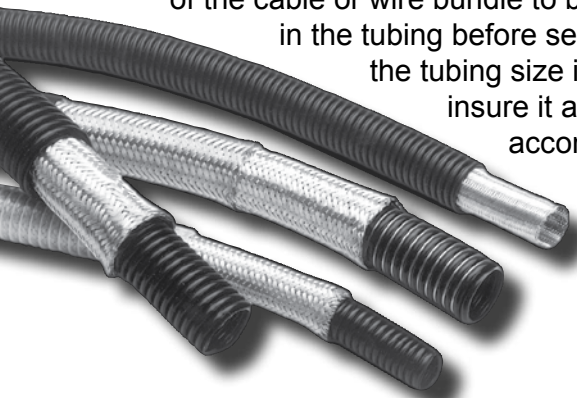
This selection guide is designed to assist you with the selection of components and planning for installation of Glenair polymer plastic and composite convoluted tubing and fittings. Convoluted tubing wire protection assemblies are made up of lengths of bulk convoluted tubing, and various combinations of conduit fittings and adapters that allow the user to efficiently terminate the tubing and attach the assembly to connectors and other interconnect interfaces. There are three basic tasks in the selection process:

- (1) Specify the size of bulk tubing which meets the volume requirements of the application.
- (2) Specify the style of bulk tubing which meets the environmental, electrical and mechanical requirements of the application.
- (3) Select the transition fittings and connector adapters that satisfy the routing and interconnect requirements of the application.

### Step 1: Select Tubing Size

Conduit size is identified by its inside diameter (ID) expressed in inches and fractions. Most of our tubing products range from 3/16 of an inch to 2 inches. The ID is referenced with a numerical size code which is used in the part number.

Convoluted tubing wire protection systems are normally filled to 80% of the inside diameter of the tube. You will need to verify the diameter of the cable or wire bundle to be housed in the tubing before selecting the tubing size in order to insure it adequately accommodates your wiring.



In some applications, such as when the tubing will ultimately be attached to a bulkhead feed-through or a stuffing tube, the diameter of the feed-through fitting needs to be taken into account when selecting the tubing size. Obviously, if the tubing needs to terminate to a one inch feed-through fitting, you should select one inch tubing. In fact, in a well-designed system, the diameter of the conduit, any necessary transition fittings, connector adapters, feed-throughs etc. should all be the same size.

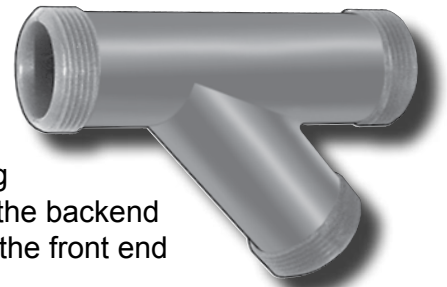
### Step 2: Select Tubing Style

Glenair manufactures a wide range of high-temperature tolerant polymer plastic convoluted tubing products, such as PFA, FEP, PTFE, ETFE and PEEK. Each material has specific performance attributes that are summarized in the accompanying table. Selection is most often based on one or more attributes such as crush resistance, strength or cost.

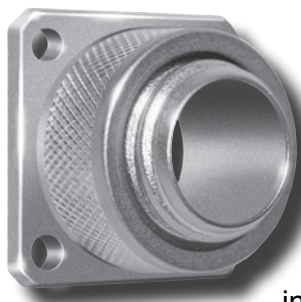
The other decision point in tubing style selection has to do with the addition of outer layers of EMI shielding and/or environmental jacketing to the core material. Braided shielding provides a conductive path for EMI and also adds pull strength to the final assembly. Various flavors of environmental jacketing, summarized in the accompanying table, protect the assembly from moisture and caustic chemicals.

### Step 3: Select Transition Fittings and Connector Adapters

Multi-branch convoluted tubing wire protection assemblies utilize various composite plastic transition fittings, in straight, "T," "Y," and "+" configurations, to facilitate routing. The tubing is terminated into the backend of the fitting while the front end



is equipped with an appropriate thread profile and coupler for the attachment of the necessary transition. The assemblies also utilize connector adapters, in straight 45° and 90° configurations, for the incorporation of circular and rectangular connectors.

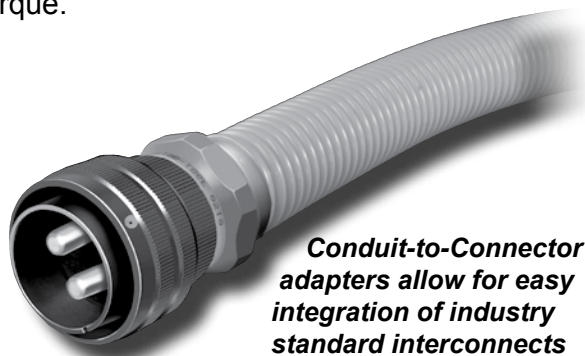


Selection is easy. The size of the fitting or adapter is indicated with a "dash number" or numeric size code that, just like the tubing, corresponds to the shell size of the part in inches and fractions. The appropriate sized fitting for a

one inch tube, for example, would be a number "32." Conveniently, this is the same number used for one inch bulk tubing. So selection is a simple matter of matching the size code in the fitting part number with the size code of the selected conduit. Your selection of a straight, 45°, 90°, "T," "Y," or "+" configuration part will depend on the routing requirements of your system.

**NOTE 1:** Glenair recommends the use of our TG70 strap wrench, or appropriately sized 600-157 series holding tools for use fitting-to-fitting, or connector-to-adapter assembly.

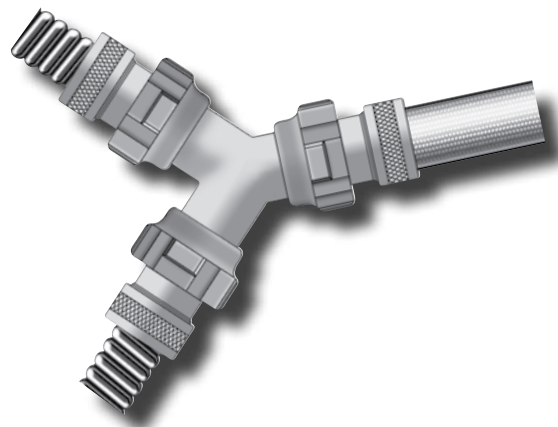
**NOTE 2:** Glenair also recommends the use of torque wrenches to ensure adapters and connectors are mated with the optimal amount of torque.



*Conduit-to-Connector adapters allow for easy integration of industry standard interconnects and convuluted tubing.*

## A Note On Braided Shielding

Glenair is able to provide turnkey convoluted tubing wire protection systems—complete with braided shielding and jacketing. Braided shields are effective at minimizing low frequency interference at audio and RF ranges. Braided shields also provide additional structural integrity while maintaining good flexibility and flex life. In use, the reduction of EMI is dependent upon the signal amplitude and frequency in relation to the many combinations of mesh count, wire diameter and the braid material. Generally, the higher the percentage of braid coverage, the more effective the shield against high-frequency emissions. Available materials include tin-plated copper, nickel-plated copper and tin-plated iron/copper as well as metal-clad composite materials such as AmberStrand®. Depending on the ratio of metal braid to composite plastic, Glenair's composite braided shielding product can reduce the weight of EMI shielding up to 75%.



*Glenair takes a systems approach to the design and manufacture of our composite and polymer plastic wire protection systems. The following pages present all the necessary component products to create 100% composite/plastic wire protection systems optimized for the most extreme environmental, mechanical, and electrical performance requirements. Please do not hesitate to contact our factory for free application engineering and assistance in the design of your next assembly.*

**Series 72**  
**High-Performance Polymer-Core**  
**Annular Convoluted Tubing**  
**Material Properties and Colors**



**Tubing Material Choices**

Y	Kynar®	Flexible, thermally stabilized, resistant to harsh chemicals and radiation. UV resistant, self-extinguishing, nontoxic and resistant to low-temperatures. 166° C temp. rating.
V	PVDF	Flexible and chemical/radiation resistant. Available in 4 colors plus standard black and natural. 150° C temperature rating.
S	G-FLEX Siltem	Lightweight, halogen-free, low toxicity, low smoke. 175° temperature rating. Ideal for harsh environment applications. Exceptional flexibility and crush resistance.

**Material Properties - Kynar® and PVDF**

Material Property	Service Temperature	Tensile Strength	Elongation	Specific Gravity
Kynar® and PVDF	-65°F/330°F (-54°C/166°C)*	5000 PSI (34,474 KP)	250%	1.8 Max
Material Property	Heat Aging	Dielectric Strength	Volume Resistivity	Water Absorption
Kynar® and PVDF	168 Hrs. @ 347°F (175°C)	10,000V	10 <sup>16</sup>	0.02%
Material Property	Solvent Resistance	Flammability	Fungus Resistance	
Kynar® and PVDF	No swelling, stickiness or weight change	Non-burning	Does not support fungus growth	

\*Note: Kynar® and PVDF material properties are identical, with the exception that Kynar® has been irradiated for thermal stability, and thus has a higher temperature rating of 166°C compared to 150° for non-thermally-stabilized PVDF.

G-FLEX Siltem is Glenair's proprietary annular polymer-core convoluted tubing formulation, developed for harsh environment applications that require a lightweight, halogen-free material with exceptional flexibility and crush resistance

**Material Properties - G-FLEX Siltem**

Material Property	Flexural Modulus	Flexural Strength	Tensile Strength	Elongation
	168,000 PSI	5590 PSI	5700 PSI	60%
Material Property	Melt Flow Rate	Dielectric Strength	Volume Resistivity	Water Absorption
	38.0 G/10 min	422.9 V/mil	>1.E+16 Ohm-cm	0.58%

**Color Options**

	Standard Black	Standard for Kynar and PVDF annular convoluted tubing materials
N	Natural/Clear	Standard for G-FLEX Siltem. Available for for all Series 72 annular convoluted tubing materials
R	Red	Available for Kynar and PVDF annular convoluted tubing materials
Y	Yellow	Available for Kynar and PVDF annular convoluted tubing materials
BL	Blue	Available for Kynar and PVDF annular convoluted tubing materials
TN	Desert Tan	Available for Kynar and PVDF annular convoluted tubing materials
O	Orange	Available for Kynar and PVDF annular convoluted tubing materials



## Series 72 Annular Polymer-Core Convoluted Tubing Material Properties and Colors

**B**

### EMI/RFI Braided Shielding and Non-Metallic (Fabric) Overbraids

T	Tin/Copper	150°C temperature rating, 125 lbs. tensile strength, 96 hr. salt spray corrosion resistance
C	Stainless Steel	Highest tensile strength (225 lbs.), highest temperature—1093°C+
N	Nickel/Copper	200°C temperature rated, 150 lbs. tensile strength, 500 hrs. salt spray corrosion resistance
S	SnCuFe	Tin plated iron/copper
L	ArmorLite™	Microfilament metal-clad ultra lightweight stainless steel braid
D	Dacron	Yarn with excellent abrasion resistance, good chemical resistance, non-conductive
M	Nomex	-55°C to 260°C temperature range - will not melt, excellent chemical resistance, non-conductive
E	AmberStrand® 100%	Expandable, flexible, high-strength conductive metal-clad composite thermoplastic
F	AmberStrand® 75%/25%	75% Expandable, flexible, high-strength conductive metal-clad composite thermoplastic combined with 25% nickel-plated 36AWG copper wire for additional strength

### Jacketing Options

N	Neoprene	Tough, durable polychloroprene for mechanical and environmental protection
H	Hypalon®	Light weight with broad temperature range
E	EPDM	Better resistance to Ketones
V	Viton	Heaviest material with best resistance to oil and gasoline
B	Duraelectric, Black	Weatherproof, halogen free, flame resistant, functional to 260°C
G	Duraelectric, Gray	Qualified to US Navy MIL-PRF-24758A, Fed Std 595B #26270 Haze Gray color
TN	Duraelectric, Desert Tan	Duraelectric in Fed Std #3446 Desert Tan color
O	Duraelectric, Orange	OSHA Safety Orange to mark energized electrical cables

### Jacketing Material Properties and Chemical Resistance

Material Property	EPDM (Ethylene Propylene Diene Monomer)	Hypalon (Chlorosulfonated Polyethylene)	Neoprene (Polychloroprene)	Viton (Fluoroelastomer)	Duraelectric
Temperature Range	-60°F to +300°F (-51°C to +149°C)	-60°F to +300°F (-51°C to +149°C)	-60°F to +250°F (-51°C to +121°C)	-40°F to +392°F (-40°C to +200°C)	-94°F to +392°F (-70°C to +200°C)
Specific Gravity	1.26	1.18	1.25	1.80	1.22
Weight: Lbs./Cubic Inch	.045	.043	.045	.055	.045
Abrasion Resistance	Excellent	Excellent	Excellent	Good	Good
Wear Resistance	Good	Good	Good	Good	Good
Flame Resistance	Good	Good	Good	Good	Excellent
Sunlight Resistance	Excellent	Excellent	Good	Excellent	Excellent
<b>Chemical Resistance</b>					
Aliphatic Hydrocarbons	Good	Good	Good	Excellent	Excellent
Aromatic Hydrocarbons	Good	Fair	Fair	Excellent	Excellent
Ketones, Etc.	Good	Poor	Poor	Poor	Excellent
Oil & Gasoline	Good	Good	Fair	Excellent	Excellent

# Introduction to Conduit Interconnect Technologies and Packaging Determining Tubing Size



## How to use the tables on this page:

It is possible for a wire bundle to contain wires of all the same size diameter, or a variety of mixed diameters. The gauge provides only the diameter of the conductor, and this information alone is not sufficient to determine required tubing size. Referring to the appropriate wire specification is necessary to establish the overall diameter over the insulation and/or braids.

STEP	ALL WIRES SAME DIAMETER	TWO DIFFERENT WIRE DIAMETERS
1. A bundle containing 30 wires	30 wires @ .045 DIA	15 wires @ .045 DIA 15 wires @ .135 DIA
2. Determine average wire diameter	30 x .045 = 1.35  1.35 = .045 Average 30 Wire Diameter	15 x .045 = .68 15 x .135 = <u>2.03</u> 2.71 2.71 = .090 Average 30 Wire Diameter
3. Using Table I, find factor for 30 wires (6.7), and multiply by average wire diameter	.045 x 6.7 = .3015 Wire Bundle Diameter	.090 x 6.7 = .603 Wire Bundle Diameter
4. Tubing size is determined on Table II. 70% fill is recommended	Size 12 (.305 DIA = 70% Fill)	Size 24 (.607 DIA = 70% Fill)



TABLE I																		
Number of Wires	1	2	3	4	5	6	7	8	9	10	12	14	16	18	20	24	28	32
Factor	1	2	2.2	2.4	2.7	2.9	3	3.3	3.8	4	4.3	4.6	5	5.3	5.6	6	6.5	6.9
Number of Wires	36	40	45	50	55	60	65	70	75	80	90	100	125	150	175	200	250	300
Factor	7.4	7.7	8.1	8.5	8.9	9.3	9.7	10.1	10.5	10.9	11.6	12.2	13.7	15	16.1	17.2	19.3	21

TABLE II					
TUBING SIZE	TUBING I.D.	50% FILL	60% FILL	70% FILL	80% FILL
6	0.187 (4.7)	0.128 (3.3)	0.14 (3.6)	0.151 (3.8)	0.162 (4.1)
9	0.281 (7.1)	0.193 (4.9)	0.211 (5.4)	0.229 (5.8)	0.244 (6.2)
10	0.312 (7.9)	0.217 (5.5)	0.237 (6.0)	0.256 (6.5)	0.274(7.0)
12	0.375 (9.5)	0.257 (6.5)	0.282 (7.2)	0.305 (7.7)	0.326 (8.3)
14	0.437 (11.1)	0.302 (7.7)	0.331 (8.4)	0.357 (9.1)	0.382 (9.7)
16	0.5 (12.7)	0.343 (8.7)	0.376 (9.6)	0.406 (10.3)	0.434 (11.0)
20	0.625 (15.9)	0.426 (10.8)	0.467 (11.9)	0.505 (12.8)	0.539 (13.7)
24	0.75 (19.1)	0.513 (13.0)	0.562 (14.3)	0.607 (15.4)	0.649 (16.5)
28	0.875 (22.2)	0.608 (15.4)	0.666 (16.9)	0.72 (18.3)	0.769 (19.5)
32	1 (25.4)	0.686 (17.4)	0.751 (19.1)	0.812 (20.6)	0.868 (22.0)
40	1.25 (31.8)	0.852 (21.6)	0.933 (23.7)	1.008 (25.6)	1.078 (27.4)

Note: Consult factory for Series 72 Type B tubing.

Metric dimensions (mm) are indicated in parentheses.

### About Glenair Series 74 Helical Convuluted Tubing Styles

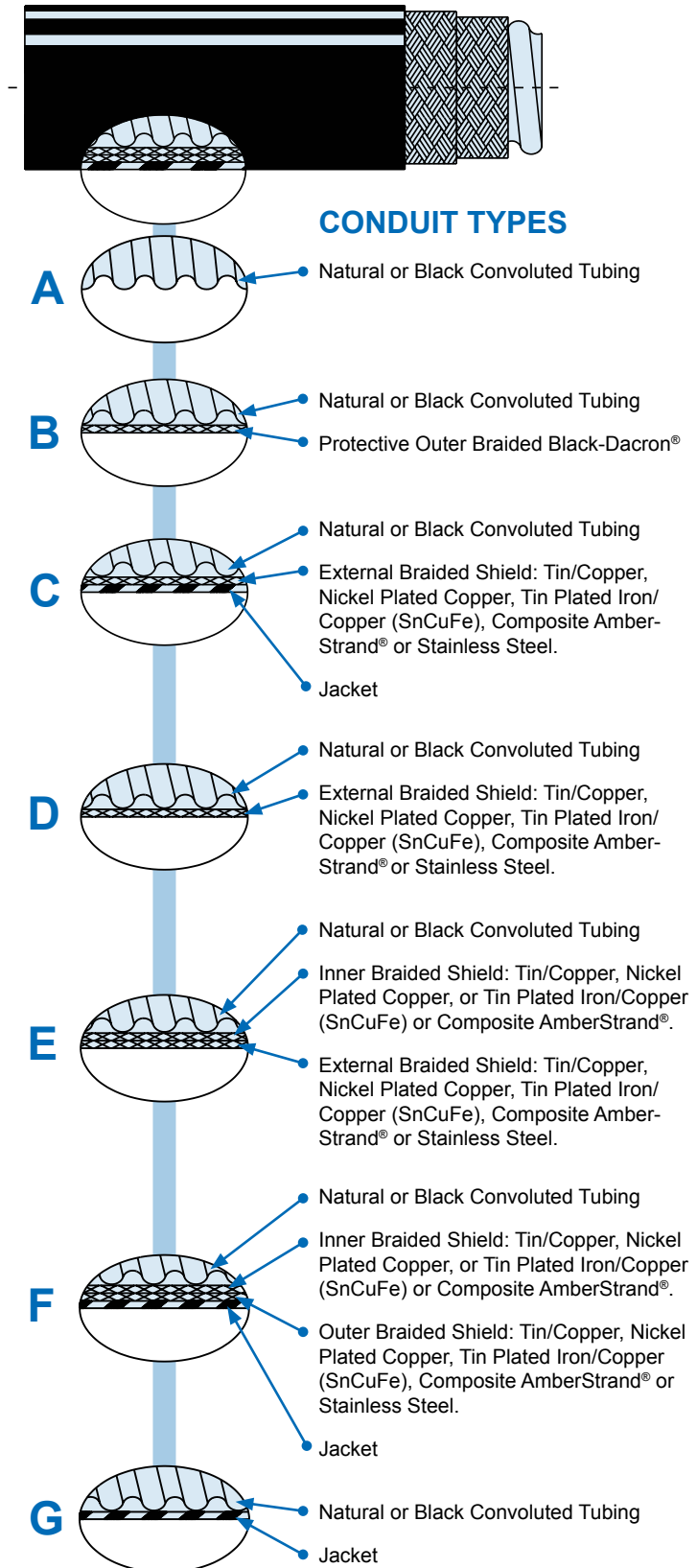
Glenair offers our polymer plastic Series 74 Helical Convuluted Tubing unshielded or with a variety of braids to meet various electromagnetic shielding requirements. Type A is provided unshielded; Type B unshielded, with a protective outer braided black Dacron® covering; Types C through F define standard combinations of braided metal EMI shielding; Type G unshielded, with an outer elastomeric jacket. Other combinations can be provided upon request.

Glenair Series 74 Helical Convuluted Tubing is manufactured in conformance to SAE-AMS-T-81914, providing the user with standard and thin wall thickness, and a choice of standard or close convolutions. For low-smoke zero-halogen applications that require a high strength and superior crush resistance, Glenair can supply PEEK™ tubing (semicrystalline thermoplastic). The PEEK™ material will be manufactured to Glenair tubing standards.

All of the Glenair convuluted tubing can be supplied either unjacketed or with a variety of elastomeric materials. Other options include: Dual wall i.e., FEP inner liner and FEP outer liner which can be supplied with various combinations of braid shielding between the liners; Reinforcement support spring option for added crush resistance which can be supplied with the Type A through Type G configurations shown; Internal braid shielding; and special processes such as cross-linking (please consult factory).

#### BULK CONDUIT LENGTH TOLERANCES

INCHES	
LENGTH	TOLERANCE
12 - 144	+ 2.0
145 - 600	+ 4.0
601 - up	+ 6.0
CENTIMETERS	
LENGTH	TOLERANCE
31 - 366	+ 5.0
367 - 1524	+ 10.2
1525 - up	+ 15.2

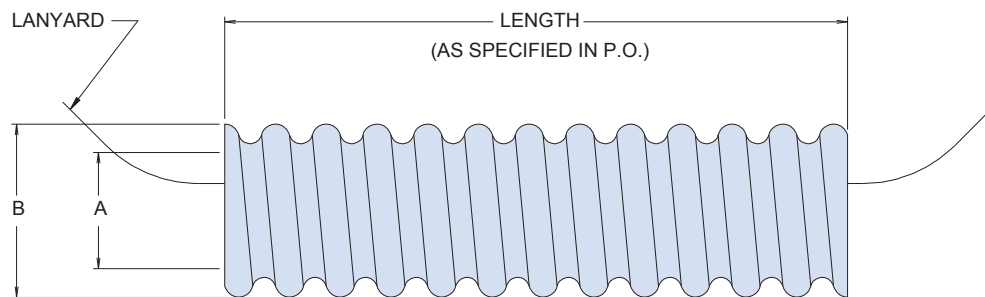
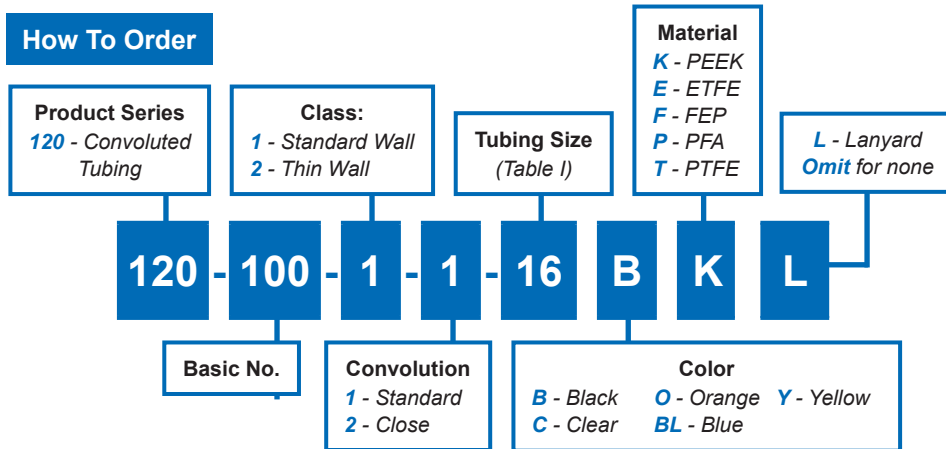


**120-100**  
**Series 74 Helical Convoluted Tubing (AMS-T-81914)**  
**Type A: Convoluted Tubing Only**



Convoluted  
Tubing

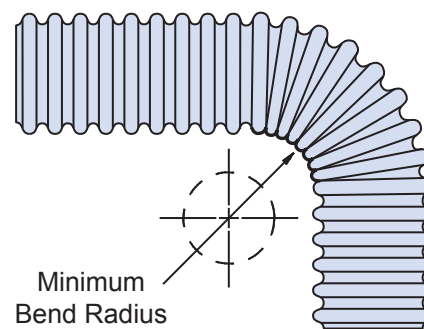
**Outstanding mechanical wire protection and lubricity for non-environmental and non-EMI/RFI applications**



C

**Table I: Tubing Size Order Number and Dimensions**

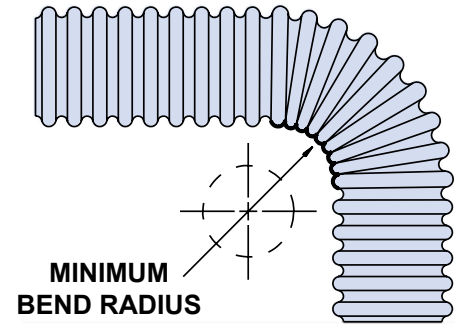
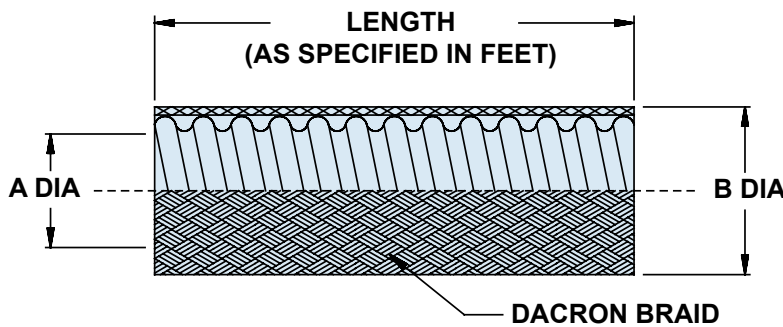
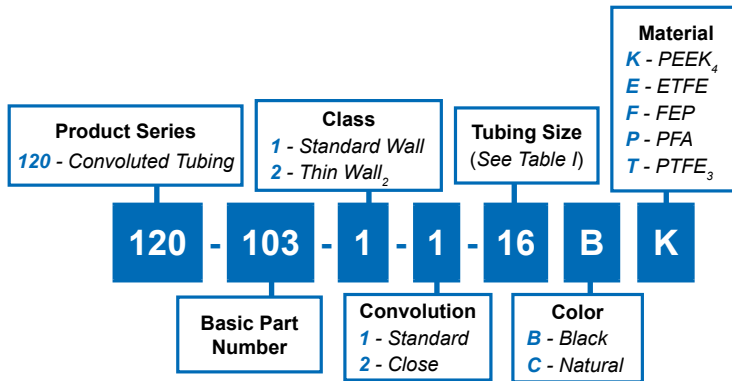
Tubing Size	Fractional Size Ref	A Inside Dia Min	B Dia Max	Min Bend Radius
06	3/16	.181 (4.6)	.320 (8.1)	.50 (12.7)
09	9/32	.273 (6.9)	.414 (10.5)	.75 (19.1)
10	5/16	.306 (7.8)	.450 (11.4)	.75 (19.1)
12	3/8	.359 (9.1)	.510 (13.0)	.88 (22.4)
14	7/16	.427 (10.8)	.571 (14.5)	1.00 (25.4)
16	1/2	.480 (12.2)	.650 (16.5)	1.25 (31.8)
20	5/8	.603 (15.3)	.770 (19.6)	1.50 (38.1)
24	3/4	.725 (18.4)	.930 (23.6)	1.75 (44.5)
28	7/8	.860 (21.8)	1.073 (27.3)	1.88 (47.8)
32	1	.970 (24.6)	1.226 (31.1)	2.25 (57.2)
40	1 1/4	1.205 (30.6)	1.539 (39.1)	2.75 (69.9)
48	1 1/2	1.437 (36.5)	1.832 (46.5)	3.25 (82.6)
56	1 3/4	1.688 (42.9)	2.156 (54.8)	3.63 (92.2)
64	2	1.937 (49.2)	2.332 (59.2)	4.25 (108.0)



**Packaging**

- Long-length orders of 120-100 conduit are subject to carrier weight and box size restrictions. For example, UPS air shipments are currently limited to 50 lbs. per box. Unless otherwise specified, Glenair standard practice is to ship optimal lengths of product based on weight, size, and individual carrier specifications.
- Consult factory for thin-wall, close convoluted combination and for PEEK™ and PTFE min/max dimensions.

**Series 74**  
**TYPE**  
**B**  
**EXTERNAL**  
**BLACK**  
**DACRON®**  
**BRAID**



**TABLE I: TUBING SIZE ORDER NUMBER AND DIMENSIONS**

TUBING SIZE	FRACTIONAL SIZE REF	A INSIDE DIA MIN		B DIA MAX		MINIMUM BEND RADIUS	
06	3/16	.181	(4.6)	.390	(9.9)	.50	(12.7)
09	9/32	.273	(6.9)	.484	(12.3)	.75	(19.1)
10	5/16	.306	(7.8)	.520	(13.2)	.75	(19.1)
12	3/8	.359	(9.1)	.580	(14.7)	.88	(22.4)
14	7/16	.427	(10.8)	.641	(16.3)	1.00	(25.4)
16	1/2	.480	(12.2)	.720	(18.3)	1.25	(31.8)
20	5/8	.603	(15.3)	.840	(21.3)	1.50	(38.1)
24	3/4	.725	(18.4)	1.000	(25.4)	1.75	(44.5)
28	7/8	.860	(21.8)	1.143	(29.0)	1.88	(47.8)
32	1	.970	(24.6)	1.296	(32.9)	2.25	(57.2)
40	1 1/4	1.205	(30.6)	1.609	(40.9)	2.75	(69.9)
48	1 1/2	1.437	(36.5)	1.902	(48.3)	3.25	(82.6)
56	1 3/4	1.688	(42.9)	2.226	(56.5)	3.63	(92.2)
64	2	1.937	(49.2)	2.402	(61.0)	4.25	(108.0)

**APPLICATION NOTES**

1. Metric dimensions (mm) are in parentheses and are for reference only.
2. Consult factory for thin-wall, close convolution combination.
3. For PTFE maximum lengths - consult factory.
4. Consult factory for PEEK™ min/max dimensions.



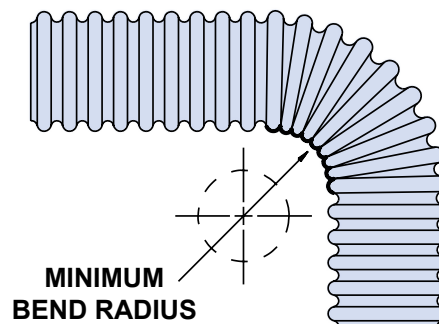
121-100

Series 74 Helical Convoluted Tubing (AMS-T-81914)  
Type C: Convoluted Tubing with External Shield and Jacket



Convuluted Tubing

Series 74  
TYPE  
C  
EXTERNAL  
SHIELD  
AND JACKET



C

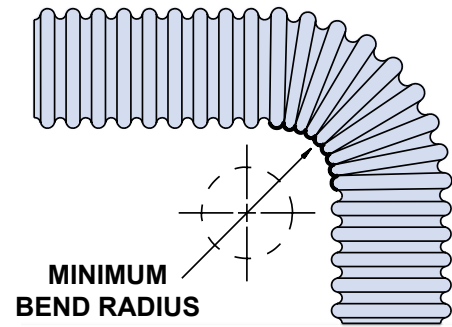
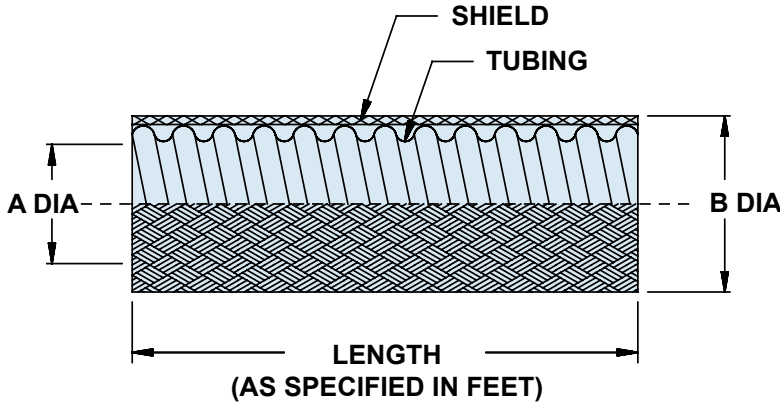
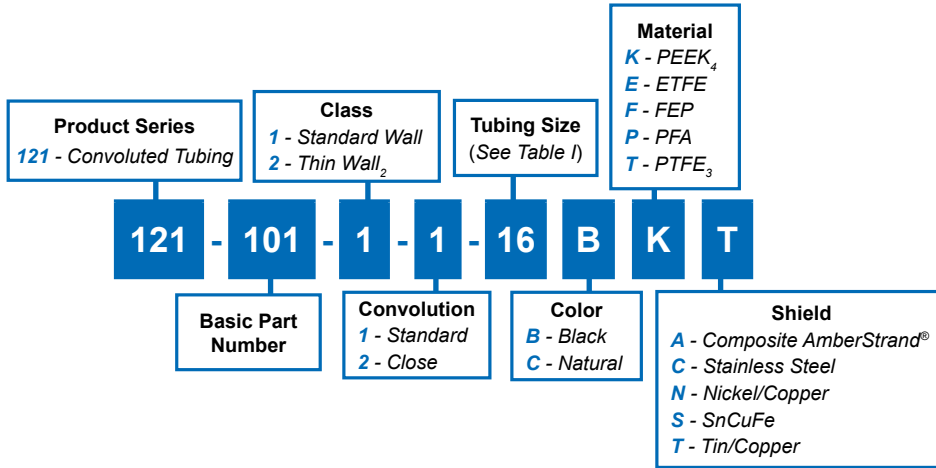
TABLE I: TUBING SIZE ORDER NUMBER AND DIMENSIONS

TUBING SIZE	FRACTIONAL SIZE REF	A INSIDE DIA MIN	B DIA MAX	MINIMUM BEND RADIUS
06	3/16	.181 (4.6)	.490 (12.4)	.50 (12.7)
09	9/32	.273 (6.9)	.584 (14.8)	.75 (19.1)
10	5/16	.306 (7.8)	.620 (15.7)	.75 (19.1)
12	3/8	.359 (9.1)	.680 (17.3)	.88 (22.4)
14	7/16	.427 (10.8)	.741 (18.8)	1.00 (25.4)
16	1/2	.480 (12.2)	.820 (20.8)	1.25 (31.8)
20	5/8	.603 (15.3)	.940 (23.9)	1.50 (38.1)
24	3/4	.725 (18.4)	1.100 (27.9)	1.75 (44.5)
28	7/8	.860 (21.8)	1.243 (31.6)	1.88 (47.8)
32	1	.970 (24.6)	1.396 (35.5)	2.25 (57.2)
40	1 1/4	1.205 (30.6)	1.709 (43.4)	2.75 (69.9)
48	1 1/2	1.437 (36.5)	2.002 (50.9)	3.25 (82.6)
56	1 3/4	1.688 (42.9)	2.327 (59.1)	3.63 (92.2)
64	2	1.937 (49.2)	2.502 (63.6)	4.25 (108.0)

APPLICATION NOTES

- Metric dimensions (mm) are in parentheses and are for reference only.
- Consult factory for thin-wall, close convolution combination.
- For PTFE maximum lengths - consult factory.
- Consult factory for PEEK™ min/max dimensions.

**Series 74**  
**TYPE**  
**D**  
**EXTERNAL**  
**SHIELD**



**TABLE I: TUBING SIZE ORDER NUMBER AND DIMENSIONS**

TUBING SIZE	FRACTIONAL SIZE REF	A INSIDE DIA MIN	B DIA MAX	MINIMUM BEND RADIUS
06	3/16	.181 (4.6)	.370 (9.4)	.50 (12.7)
09	9/32	.273 (6.9)	.464 (11.8)	.75 (19.1)
10	5/16	.306 (7.8)	.500 (12.7)	.75 (19.1)
12	3/8	.359 (9.1)	.560 (14.2)	.88 (22.4)
14	7/16	.427 (10.8)	.621 (15.8)	1.00 (25.4)
16	1/2	.480 (12.2)	.700 (17.8)	1.25 (31.8)
20	5/8	.603 (15.3)	.820 (20.8)	1.50 (38.1)
24	3/4	.725 (18.4)	.980 (24.9)	1.75 (44.5)
28	7/8	.860 (21.8)	1.123 (28.5)	1.88 (47.8)
32	1	.970 (24.6)	1.276 (32.4)	2.25 (57.2)
40	1 1/4	1.205 (30.6)	1.589 (40.4)	2.75 (69.9)
48	1 1/2	1.437 (36.5)	1.882 (47.8)	3.25 (82.6)
56	1 3/4	1.688 (42.9)	2.132 (54.2)	3.63 (92.2)
64	2	1.937 (49.2)	2.382 (60.5)	4.25 (108.0)

**APPLICATION NOTES**

- Metric dimensions (mm) are in parentheses and are for reference only.
- Consult factory for thin-wall, close convolution combination.
- For PTFE maximum lengths - consult factory.
- Consult factory for PEEK™ min/max dimensions.

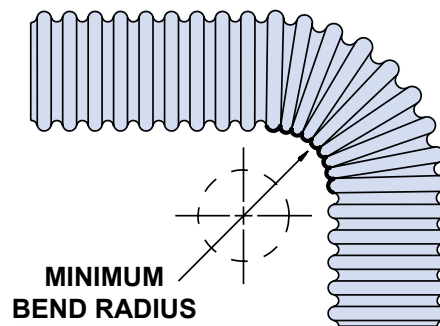
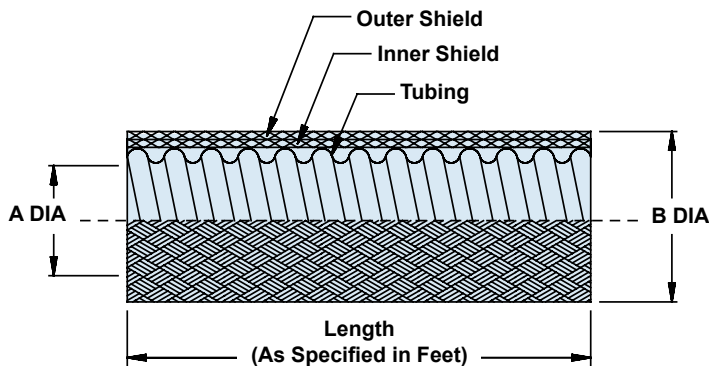
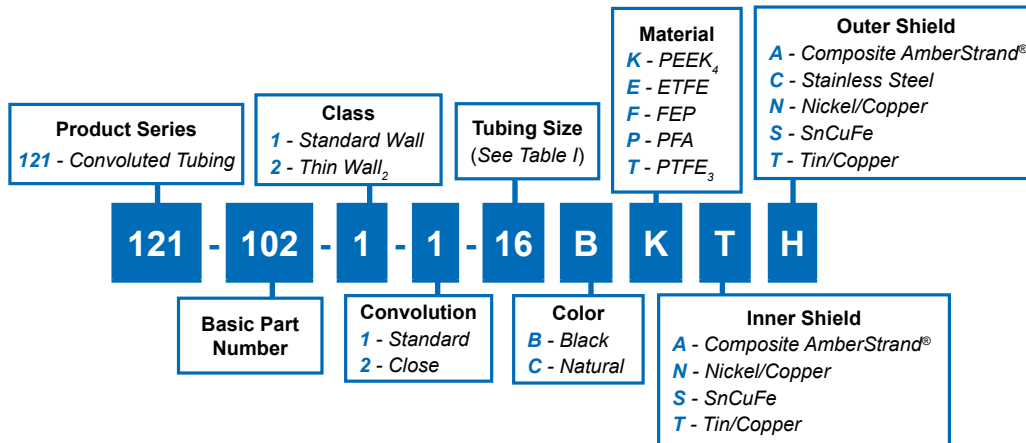
121-102

**Series 74 Helical Convoluted Tubing (AMS-T-81914)**  
**Type E: Convoluted Tubing with Two External Shields**



Convoluted  
Tubing

**Series 74**  
**TYPE**  
**E**  
**TWO**  
**EXTERNAL**  
**SHIELDS**



C

**TABLE I: TUBING SIZE ORDER NUMBER AND DIMENSIONS**

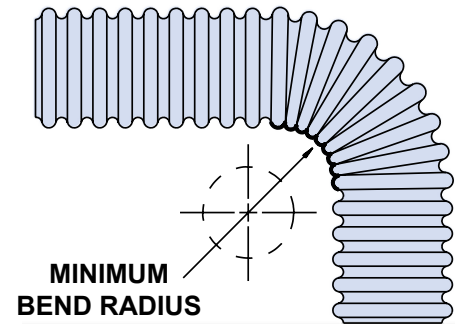
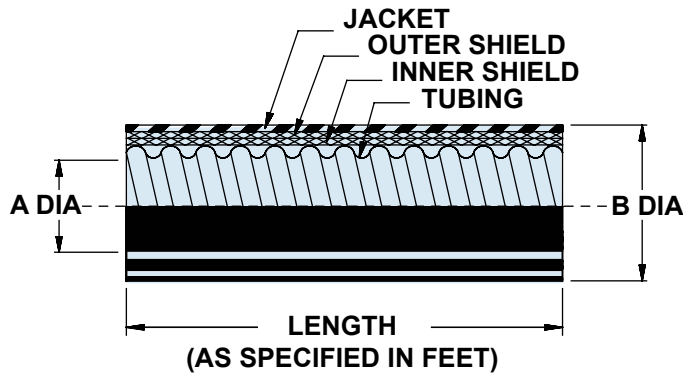
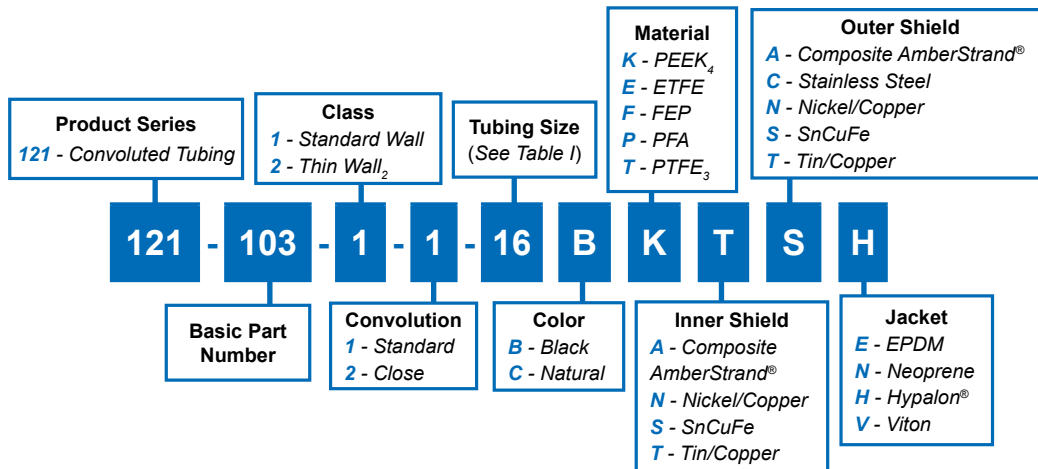
TUBING SIZE	FRACTIONAL SIZE REF	A INSIDE DIA MIN	B DIA MAX	MINIMUM BEND RADIUS *
06	3/16	.181 (4.6)	.420 (10.7)	.50 (12.7)
09	9/32	.273 (6.9)	.514 (13.1)	.75 (19.1)
10	5/16	.306 (7.8)	.550 (14.0)	.75 (19.1)
12	3/8	.359 (9.1)	.610 (15.5)	.88 (22.4)
14	7/16	.427 (10.8)	.671 (17.0)	1.00 (25.4)
16	1/2	.480 (12.2)	.750 (19.1)	1.25 (31.8)
20	5/8	.603 (15.3)	.870 (22.1)	1.50 (38.1)
24	3/4	.725 (18.4)	1.030 (26.2)	1.75 (44.5)
28	7/8	.860 (21.8)	1.173 (29.8)	1.88 (47.8)
32	1	.970 (24.6)	1.326 (33.7)	2.25 (57.2)
40	1 1/4	1.205 (30.6)	1.639 (41.6)	2.75 (69.9)
48	1 1/2	1.437 (36.5)	1.932 (49.1)	3.25 (82.6)
56	1 3/4	1.688 (42.9)	2.182 (55.4)	3.63 (92.2)
64	2	1.937 (49.2)	2.432 (61.8)	4.25 (108.0)

\*The minimum bend radius is based on Type A construction. For multiple-braided coverings, these minimum bend radii may be increased slightly.

**APPLICATION NOTES**

- Metric dimensions (mm) are in parentheses and are for reference only.
- Consult factory for thin-wall, close convolution combination.
- For PTFE maximum lengths - consult factory.
- Consult factory for PEEK™ min/max dimensions.

**Series 74  
TYPE  
F  
JACKET  
AND TWO  
EXTERNAL  
SHIELDS**



**TABLE I: TUBING SIZE ORDER NUMBER AND DIMENSIONS**

TUBING SIZE	FRACTIONAL SIZE REF	A INSIDE DIA MIN	B DIA MAX	MINIMUM BEND RADIUS *
06	3/16	.181 (4.6)	.540 (13.7)	.50 (12.7)
09	9/32	.273 (6.9)	.634 (16.1)	.75 (19.1)
10	5/16	.306 (7.8)	.670 (17.0)	.75 (19.1)
12	3/8	.359 (9.1)	.730 (18.5)	.88 (22.4)
14	7/16	.427 (10.8)	.791 (20.1)	1.00 (25.4)
16	1/2	.480 (12.2)	.870 (22.1)	1.25 (31.8)
20	5/8	.603 (15.3)	.990 (25.1)	1.50 (38.1)
24	3/4	.725 (18.4)	1.150 (29.2)	1.75 (44.5)
28	7/8	.860 (21.8)	1.293 (32.8)	1.88 (47.8)
32	1	.970 (24.6)	1.446 (36.7)	2.25 (57.2)
40	1 1/4	1.205 (30.6)	1.759 (44.7)	2.75 (69.9)
48	1 1/2	1.437 (36.5)	2.052 (52.1)	3.25 (82.6)
56	1 3/4	1.688 (42.9)	2.302 (58.5)	3.63 (92.2)
64	2	1.937 (49.2)	2.552 (64.8)	4.25 (108.0)

\*The minimum bend radius is based on Type A construction. For multiple-braided coverings, these minimum bend radii may be increased slightly.

**APPLICATION NOTES**

- Metric dimensions (mm) are in parentheses and are for reference only.
- Consult factory for thin-wall, close convolution combination.
- For PTFE maximum lengths consult factory.
- Consult factory for PEEK™ min/max dimensions.

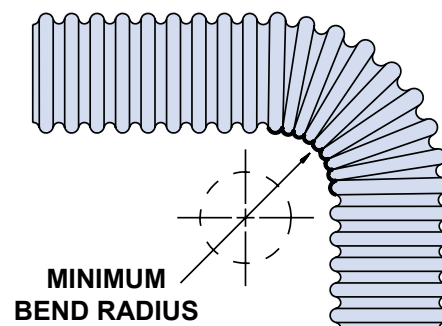
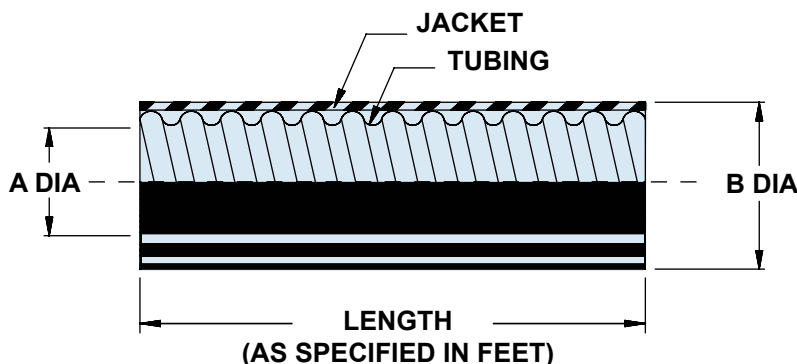
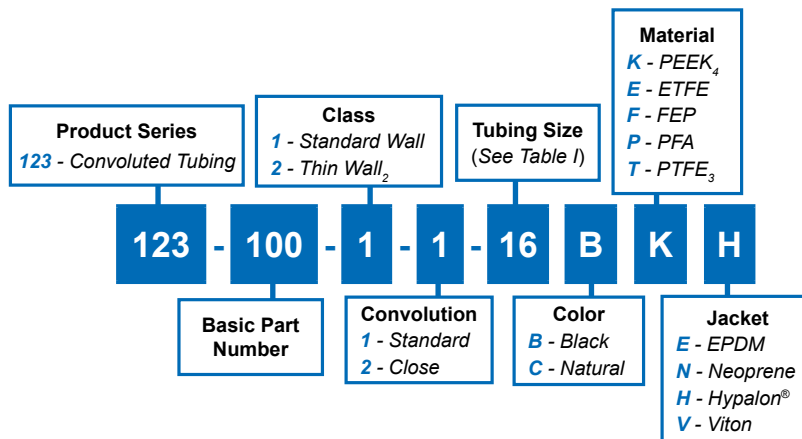
123-100

Series 74 Helical Convoluted Tubing (AMS-T-81914)  
Type G: Convoluted Tubing with Jacket



Convoluted Tubing

Series 74  
TYPE  
G  
EXTERNAL  
JACKET



C

TABLE I: TUBING SIZE ORDER NUMBER AND DIMENSIONS

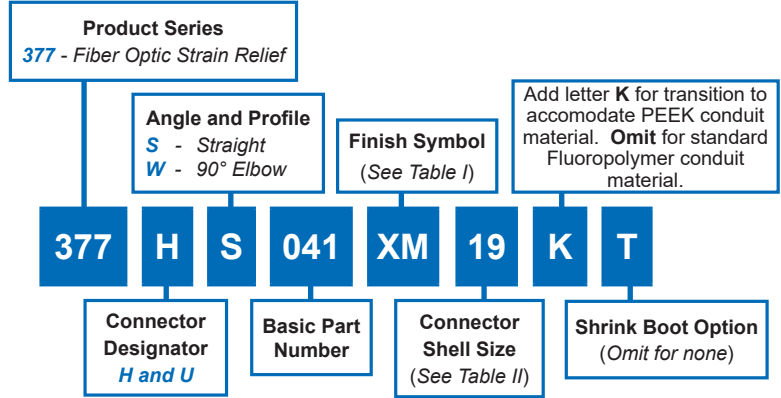
TUBING SIZE	FRACTIONAL SIZE REF	A INSIDE DIA MIN	B DIA MAX	MINIMUM BEND RADIUS
06	3/16	.181 (4.6)	.460 (11.7)	.50 (12.7)
09	9/32	.273 (6.9)	.554 (14.1)	.75 (19.1)
10	5/16	.306 (7.8)	.590 (15.0)	.75 (19.1)
12	3/8	.359 (9.1)	.650 (16.5)	.88 (22.4)
14	7/16	.427 (10.8)	.711 (18.1)	1.00 (25.4)
16	1/2	.480 (12.2)	.790 (20.1)	1.25 (31.8)
20	5/8	.603 (15.3)	.910 (23.1)	1.50 (38.1)
24	3/4	.725 (18.4)	1.070 (27.2)	1.75 (44.5)
28	7/8	.860 (21.8)	1.213 (30.8)	1.88 (47.8)
32	1	.970 (24.6)	1.366 (34.7)	2.25 (57.2)
40	1 1/4	1.205 (30.6)	1.679 (42.6)	2.75 (69.9)
48	1 1/2	1.437 (36.5)	1.972 (50.1)	3.25 (82.6)
56	1 3/4	1.688 (42.9)	2.222 (56.4)	3.63 (92.2)
64	2	1.937 (49.2)	2.472 (62.8)	4.25 (108.0)

APPLICATION NOTES

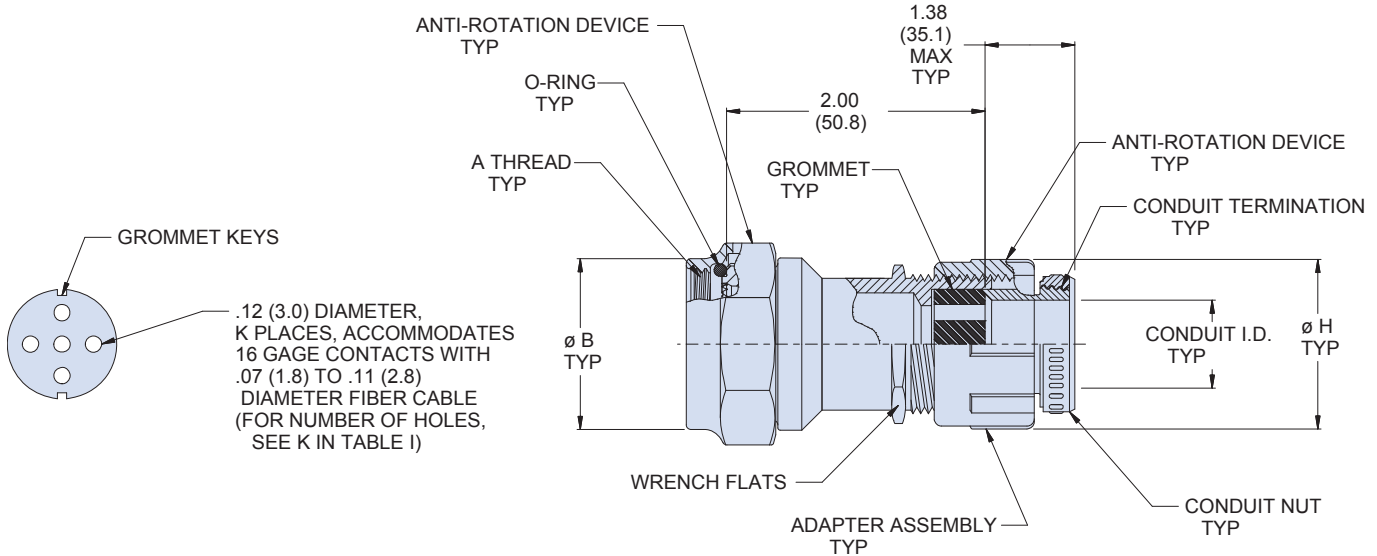
- Metric dimensions (mm) are in parentheses and are for reference only.
- Consult factory for thin-wall, close convolution combination.
- For PTFE maximum lengths consult factory.
- Consult factory for PEEK™ min/max dimensions.

# 377-041 Composite Fiber-Optic Conduit Backshell Self-Locking Rotatable Coupling

<b>CONNECTOR DESIGNATOR:</b>
<b>H</b> - MIL-DTL-38999 Series III and IV <b>U</b> - DG123 and DG123A
<b>SELF-LOCKING</b>
<b>ROTATABLE COUPLING</b>
<b>STANDARD PROFILE</b>



**C**

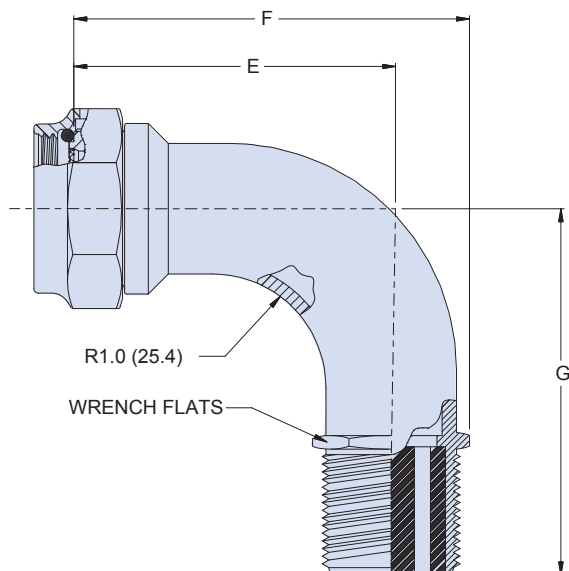


**Note: See Table II For Front-End Details and Shell Size References**

# 377-041 Composite Fiber-Optic Conduit Backshell Self-Locking Rotatable Coupling



Convuluted  
Tubing



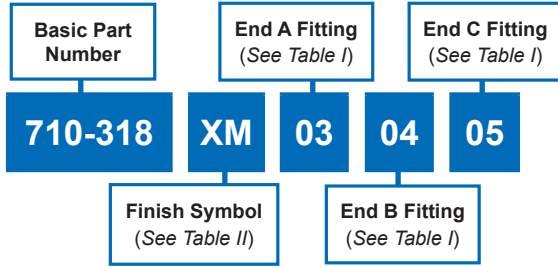
C

Table I

Shell Size	A Thread	Ø B Max	E ±.06 (1.5)	F ±.09 (2.3)	G ±.06 (1.5)	Ø H Max	Ø J Ref	K (# Of Holes)
11	M15 X 1 - 6H	.770 (19.6)	1.70 (43.2)	2.39 (60.7)	1.90 (48.3)	1.41 (35.8)	.25 (6.4)	2
13	M18 X 1 - 6H	.890 (22.6)	1.78 (45.2)	2.47 (62.7)	1.96 (49.8)	1.41 (35.8)	.31 (7.9)	4
15	M22 X 1 - 6H	1.03 (26.2)	1.82 (46.2)	2.51 (63.8)	2.02 (51.3)	1.41 (35.8)	.31 (7.9)	5
17	M25 X 1 - 6H	1.15 (29.2)	1.89 (48.0)	2.70 (68.6)	2.09 (53.1)	1.64 (41.7)	.44 (11.2)	8
19	M28 X 1 - 6H	1.28 (32.5)	1.93 (49.0)	2.74 (69.6)	2.13 (54.1)	1.64 (41.7)	.50 (12.7)	11
21	M31 X 1 - 6H	1.41 (35.8)	2.00 (50.8)	2.94 (74.7)	2.19 (55.6)	1.89 (48.0)	.50 (12.7)	16
23	M34 X 1 - 6H	1.53 (38.9)	2.08 (52.8)	3.02 (76.7)	2.25 (57.2)	1.89 (48.0)	.63 (16.0)	21
25	M37 X 1 - 6H	1.66 (42.2)	2.14 (54.4)	3.20 (81.3)	2.32 (58.9)	2.16 (54.9)	.75 (19.1)	29

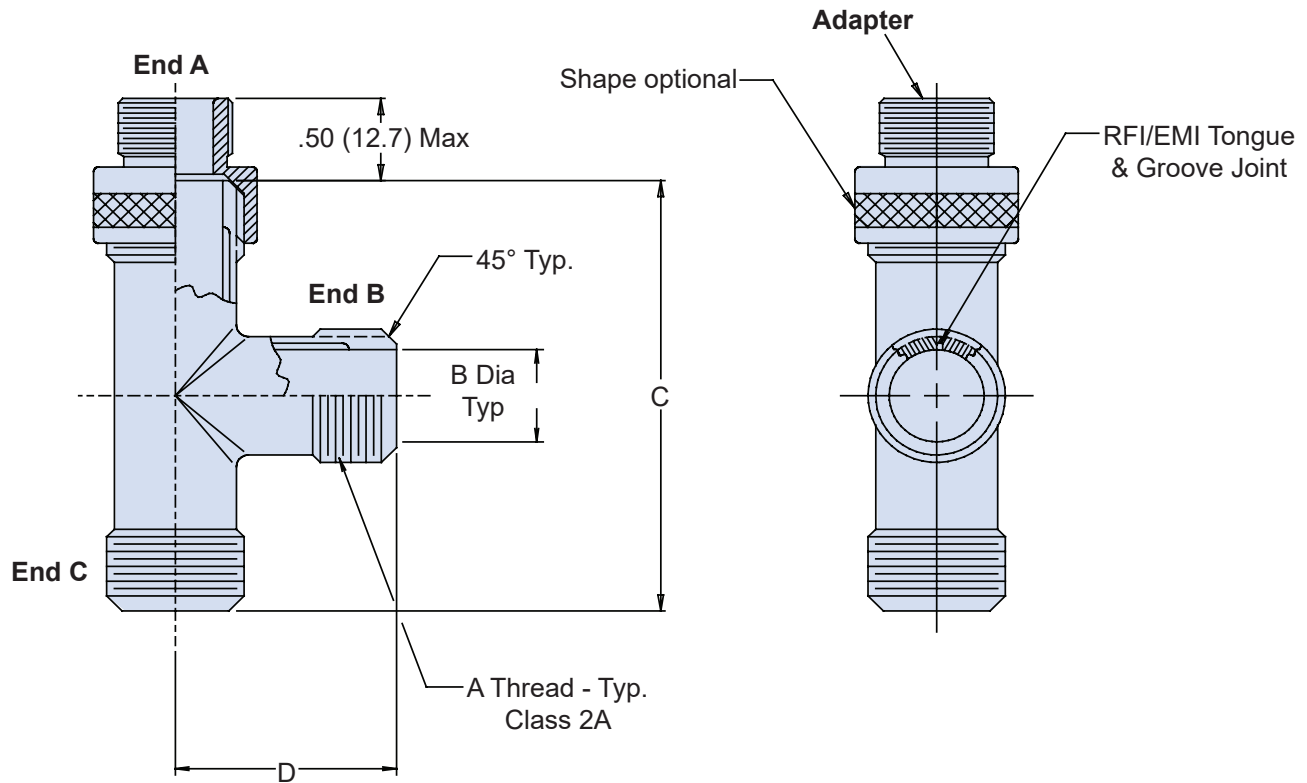
Table II: Material and Finish

Code	Material	Finish Description	Components
XB	Composite	No Plating - Black Color	Elbow, Adapter, Coupling Nut and RFI Nut
XM		1000 Hr. Corrosion-Resistant Electroless Nickel	Adapter and RFI Nut
XW		1000 Hr. Corrosion-Resistant Cadmium Olive Drab over Electroless Nickel	Adapter and RFI Nut
XV		No Plating - Purple or Black Color (mfg. option)	Straight Body and Rear Adapter
		No Plating - Purple Color	Elbow Body, Coupling Nut, and Rear Nut



### APPLICATION NOTES

1. Metric dimensions (mm) are in parentheses and are for reference only.
2. Transitions mate to 710S269, S270 and S271 adapters.
3. When all ends are identical, insert only one dash number. When multiple dash numbers are ordered, transition size will be determined by the largest. Adapter may be supplied on smaller entries. Letter to follow entry will be supplied with adapters.



**TABLE I: END ORDER NUMBER AND DIMENSIONS**

End No.	A Thread		B Dia	C Max	D Max	Weight in Pounds Max.
	Unified					
01	.750 - 20		.500 (12.7)	2.375 (60.3)	1.187 (30.1)	.082
02	1.000 - 20		.750 (19.1)	2.625 (66.7)	1.312 (33.3)	.114
03	1.312 - 18		1.000 (25.4)	2.875 (73.0)	1.437 (36.5)	.160
04	1.500 - 18		1.250 (31.8)	3.125 (79.4)	1.652 (42.0)	.191
05	2.000 - 18		1.625 (41.3)	3.500 (88.9)	1.750 (44.5)	.273
06	.500 - 20		.281 (7.1)	2.125 (54.0)	1.062 (27.0)	.031
07	.625 - 24		.375 (9.5)	2.250 (57.2)	1.125 (28.6)	.043

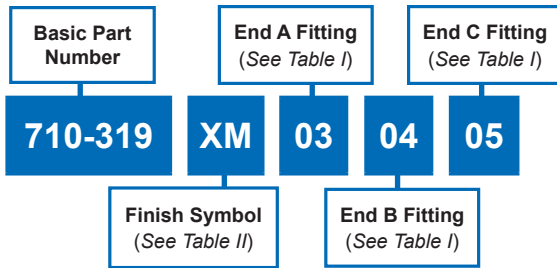
Table II: Finish	
Code	Finish Description
XM	1000 Hr. Corrosion-Resistant Electroless Nickel
XW	1000 Hr. Corrosion-Resistant Cadmium Olive Drab over Electroless Nickel
XB	No Plating - Black Color
XV	No Plating - Purple Color



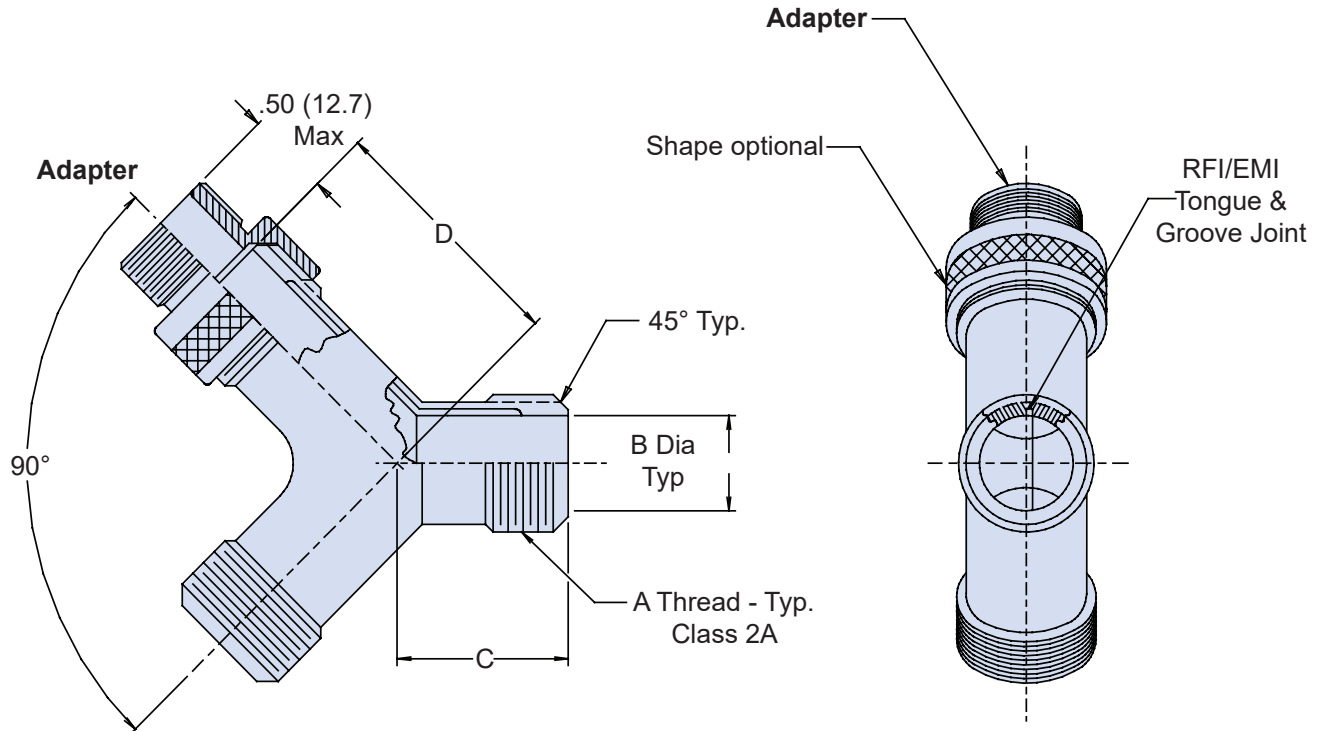
# 710-319 Composite Split Junction Fitting "Y" Configuration



Convolved  
Tubing



- ### APPLICATION NOTES
1. Metric dimensions (mm) are in parentheses and are for reference only.
  2. Transitions mate to 710S269, S270 and S271 adapters.
  3. When all ends are identical, insert only one dash number. When multiple dash numbers are ordered, transition size will be determined by the largest. Adapter may be supplied on smaller entries. Letter to follow entry will be supplied with adapters.

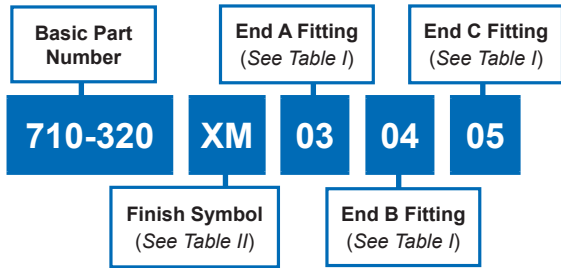


End No.	A Thread Unified	B Dia	C Max	D Max
01	.750 - 20	.500 (12.7)	1.312 (33.3)	1.312 (33.3)
02	1.000 - 20	.750 (19.1)	1.500 (38.1)	1.500 (38.1)
03	1.312 - 18	1.000 (25.4)	1.937 (49.2)	1.937 (49.2)
04	1.500 - 18	1.250 (31.8)	2.187 (55.5)	2.187 (55.5)
05	2.000 - 18	1.625 (41.3)	2.625 (66.7)	2.625 (66.7)

Code	Finish Description
XM	1000 Hr. Corrosion-Resistant Electroless Nickel
XW	1000 Hr. Corrosion-Resistant Cadmium Olive Drab over Electroless Nickel
XB	No Plating - Black Color
XV	No Plating - Purple Color

C

# 710-320 Composite Split Junction Fitting Straight with 45° Branch Configuration



**APPLICATION NOTES**

1. Metric dimensions (mm) are in parentheses and are for reference only.
2. Transitions mate to 710S269, S270 and S271 adapters.
3. When all ends are identical, insert only one dash number. When multiple dash numbers are ordered, transition size will be determined by the largest. Adapter may be supplied on smaller entries. Letter to follow entry will be supplied with adapters.

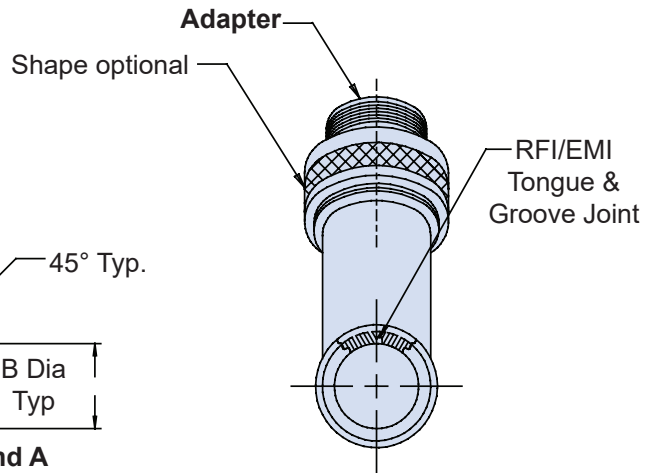
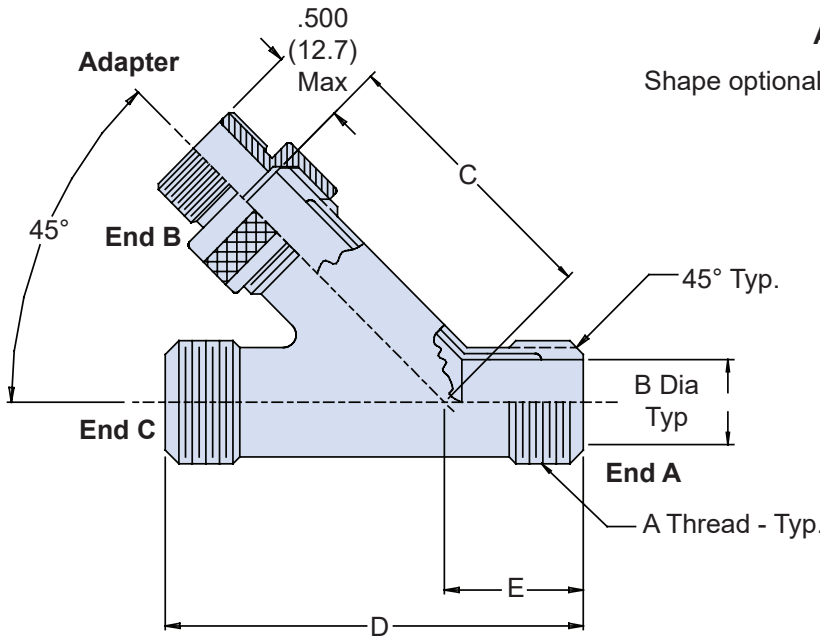
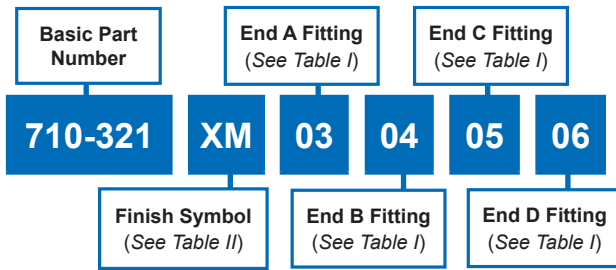


Table II: Finish	
Code	Finish Description
XM	1000 Hr. Corrosion-Resistant Electroless Nickel
XW	1000 Hr. Corrosion-Resistant Cadmium Olive Drab over Electroless Nickel
XB	No Plating - Black Color
XV	No Plating - Purple Color

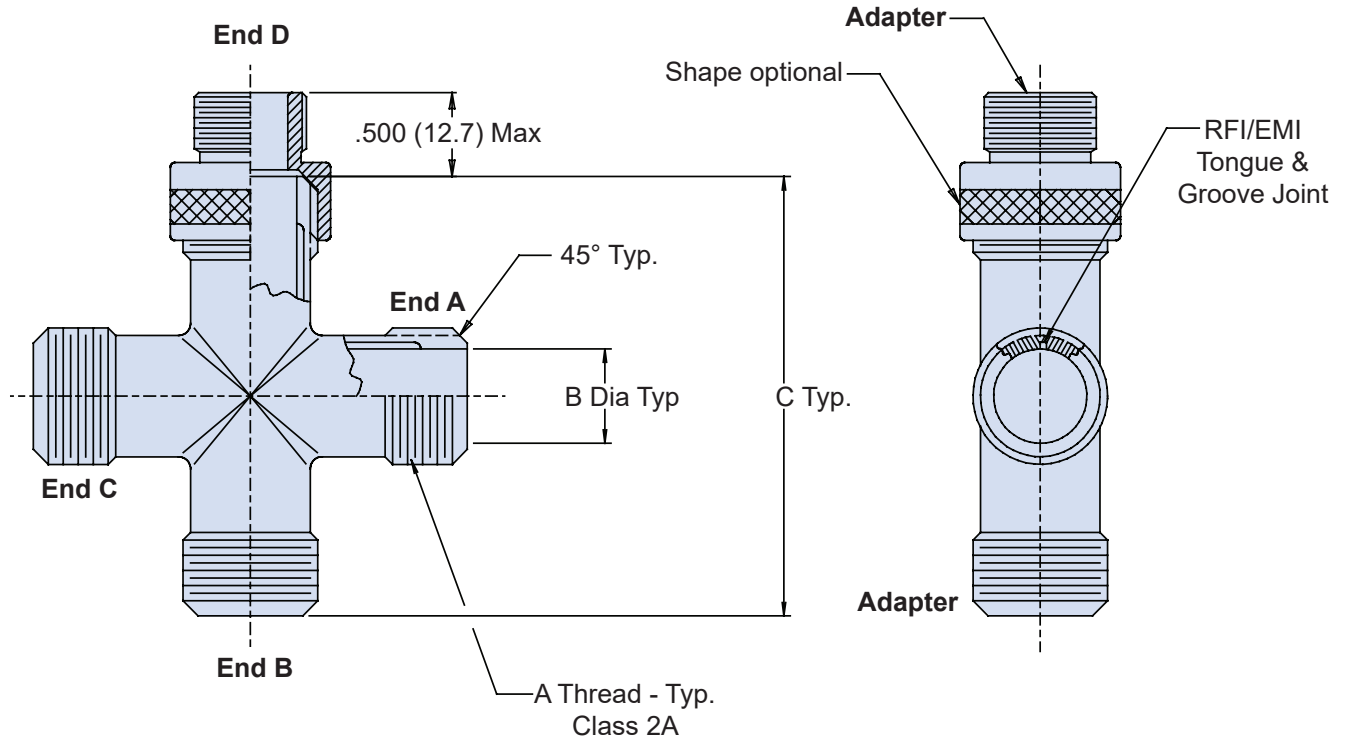
TABLE I: END ORDER NUMBER AND DIMENSIONS							
End No.	A Thread		B Dia	C Max	D Max	E Max	Weight in Pounds Max.
	Unified						
01	.750 - 20		.500 (12.7)	2.250 (57.2)	3.000 (76.2)	1.125 (28.6)	.093
02	1.000 - 20		.750 (19.1)	2.500 (63.5)	3.375 (85.7)	1.188 (30.2)	.132
03	1.312 - 18		1.000 (25.4)	2.875 (73.0)	4.000 (101.6)	1.333 (33.9)	.192
04	1.500 - 18		1.250 (31.8)	3.125 (79.4)	4.375 (111.1)	1.458 (37.0)	.235
05	2.000 - 18		1.625 (41.3)	3.625 (92.1)	5.125 (130.2)	1.708 (43.4)	.347
06	.500 - 20		.281 (7.1)	1.750 (44.5)	2.625 (66.7)	1.000 (25.4)	.034
07	.625 - 24		.375 (9.5)	2.062 (52.4)	2.750 (69.9)	1.062 (27.0)	.047

# 710-321 Composite Split Junction Fitting Plus ("+") Configuration



**APPLICATION NOTES**

1. Metric dimensions (mm) are in parentheses and are for reference only.
2. Transitions mate to 710S269, S270 and S271 adapters.
3. When all ends are identical, insert only one dash number. When multiple dash numbers are ordered, transition size will be determined by the largest. Adapter may be supplied on smaller entries. Letter to follow entry will be supplied with adapters.



**TABLE I: END ORDER NUMBER AND DIMENSIONS**

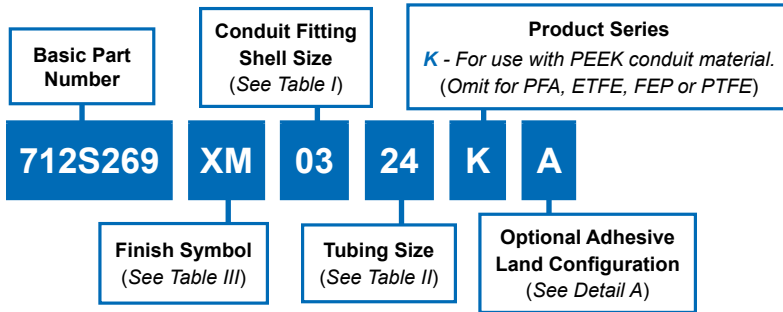
End No.	A Thread Unified	B Dia	C Max	Weight in Pounds Max.
01	.750 - 20	.500 (12.7)	2.375 (60.3)	.109
02	1.000 - 20	.750 (19.1)	2.625 (66.7)	.152
03	1.312 - 18	1.000 (25.4)	2.875 (73.0)	.213
04	1.500 - 18	1.250 (31.8)	3.125 (79.4)	.254
05	2.000 - 18	1.625 (41.3)	3.500 (88.9)	.364
06	.500 - 20	.281 (7.1)	2.125 (54.0)	.041
07	.625 - 24	.375 (9.5)	2.250 (57.2)	.057

**Table II: Finish**

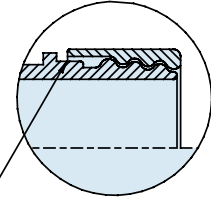
Code	Finish Description
XM	1000 Hr. Corrosion-Resistant Electroless Nickel
XW	1000 Hr. Corrosion-Resistant Cadmium Olive Drab over Electroless Nickel
XB	No Plating - Black Color
XV	No Plating - Purple Color



# 712S269 Composite Shrink Boot Conduit Fitting For Glenair Series 74 Helical Convulved Tubing



**DETAIL A**  
Optional Adhesive Land Configuration  
(See Part Number)



Land area to accommodate adhesive

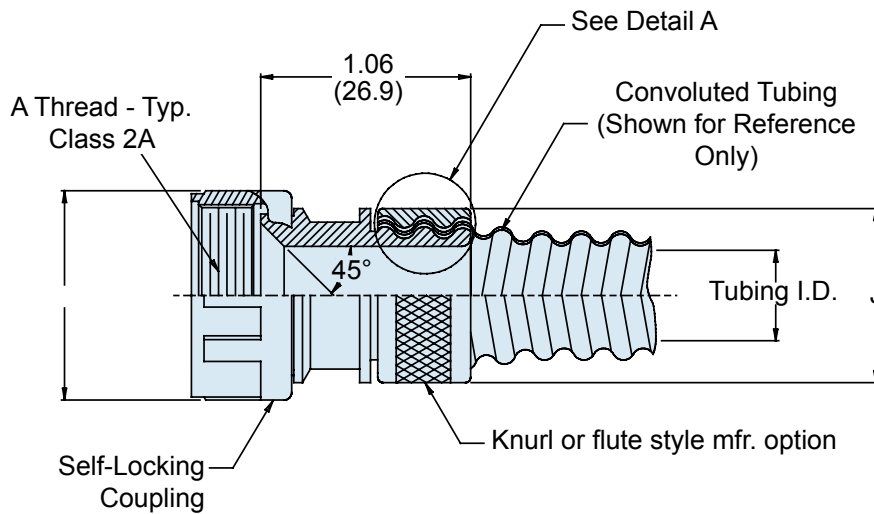


TABLE III	
Symbol	Finish Description
XB	No Plating - Black Color (Non-Conductive Finish)
XM	2000 Hour Corrosion Resistant Electroless Nickel
XMT	2000 Hour Corrosion Resistant Ni-PTFE, Nickel-Fluorocarbon Polymer. 1000 Hour Grey™
XO	No Plating - Brown Color (Non-Conductive Finish)
XW	2000 Hour Corrosion Resistant Cadmium/Olive Drab over Electroless Nickel

**TABLE II: TUBING SIZE**

Tubing Size	Conduit I.D.	J Dia Max
06	.188 (4.8)	.790 (20.1)
09	.281 (7.1)	.985 (25.0)
10	.312 (7.9)	.985 (25.0)
12	.375 (9.5)	1.035 (26.3)
14	.437 (11.1)	1.100 (27.9)
16	.500 (12.7)	1.160 (29.5)
20	.625 (15.9)	1.285 (32.6)
24	.750 (19.1)	1.480 (37.6)
28	.875 (22.2)	1.670 (42.4)
32	1.000 (25.4)	1.720 (43.7)
40	1.250 (31.8)	2.100 (53.3)
48	1.500 (38.1)	2.420 (61.5)
56	1.750 (44.5)	2.660 (67.6)
64	2.000 (50.8)	2.910 (73.9)

**TABLE I: CONDUIT FITTING SHELL SIZE**

Shell Size	A Thread Unified	Max Conduit Size Table 2	Weight in Pounds Max.
01	.750 - 20	16	.032
02	1.000 - 20	24	.043
03	1.312 - 18	32	.057
04	1.500 - 18	40	.070
05	2.000 - 18	64	.094
06	.500 - 20	09	.030
07	.625 - 24	12	.031

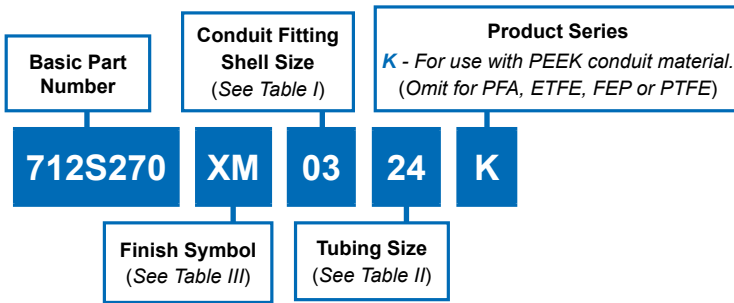
**APPLICATION NOTES**

1. Metric dimensions (mm) are in parentheses and are for reference only.
2. Convulved tubing to be ordered separately. See Type A.
3. Mates to 710-318, -319, -320 and -321 transitions
4. Coupling nut supplied unplated.
5. For permanent termination use 3M Scotch Weld after installing tubing. See detail A.

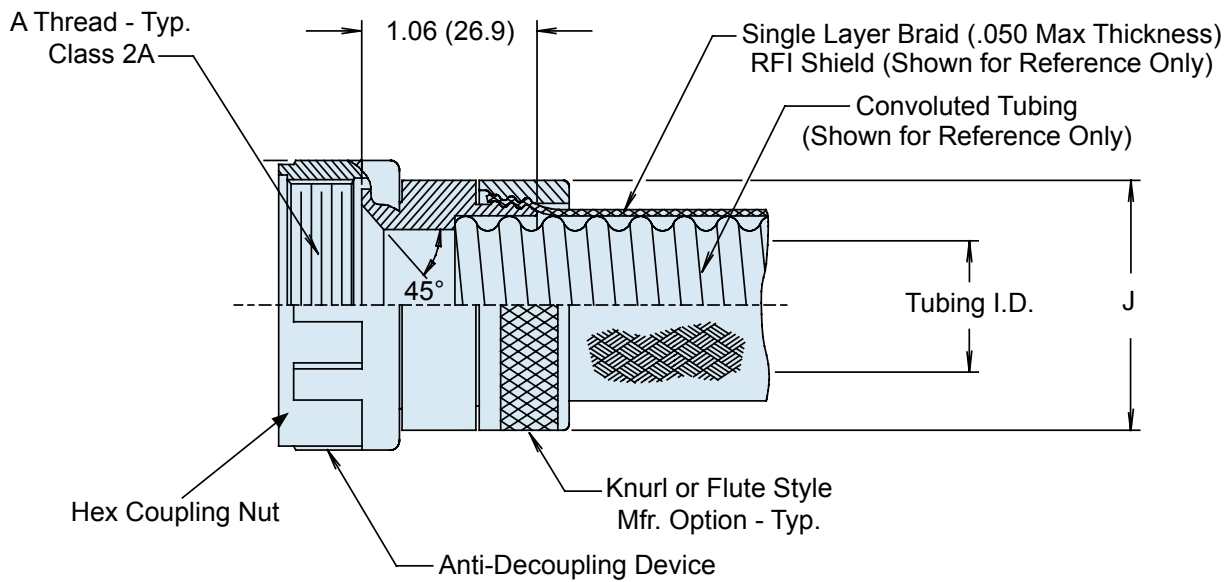
# 712S270 Composite EMI/RFI Single Shield Termination Conduit Fitting For Glenair Series 74 Helical Convulsed Tubing



Convulsed  
Tubing



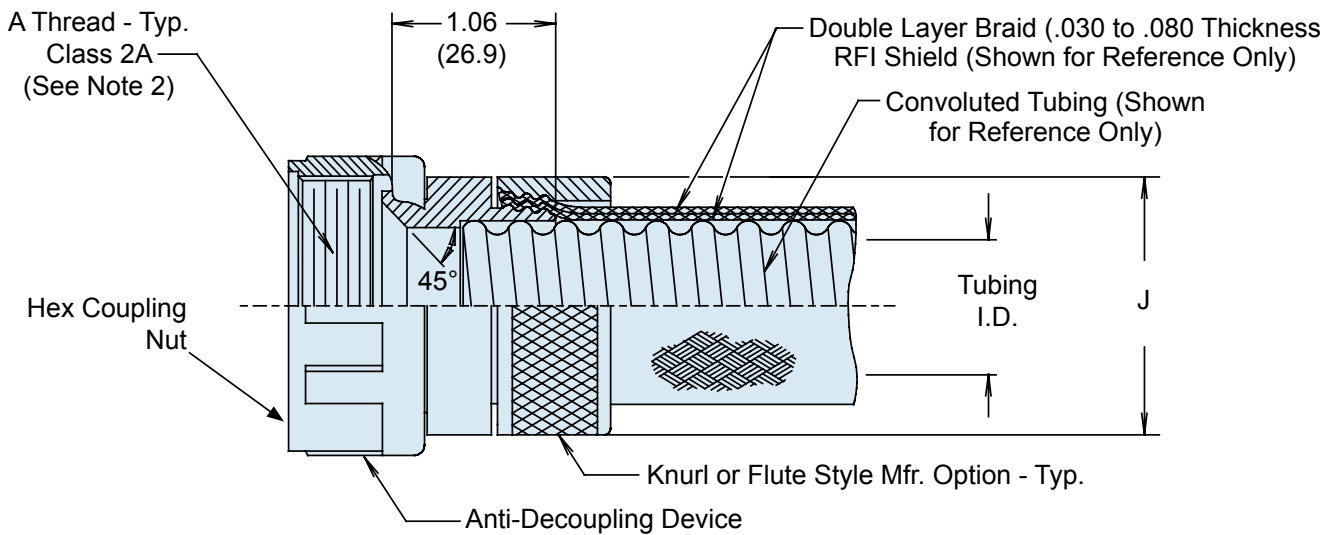
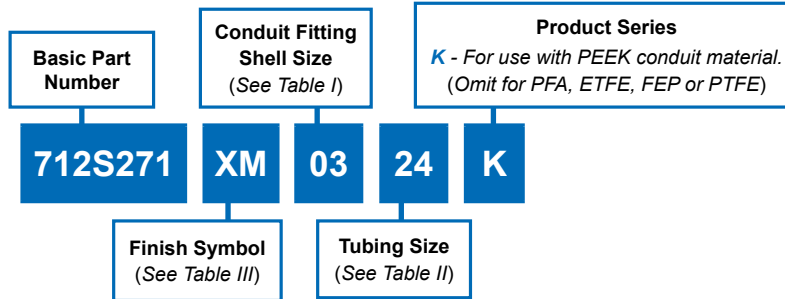
Symbol	Finish Description
XB	No Plating - Black Color (Non-Conductive Finish)
XM	2000 Hour Corrosion Resistant Electroless Nickel
XMT	2000 Hour Corrosion Resistant Ni-PTFE, Nickel-Fluorocarbon Polymer. 1000 Hour Grey™
XO	No Plating - Brown Color (Non-Conductive Finish)
XW	2000 Hour Corrosion Resistant Cadmium/Olive Drab over Electroless Nickel



Shell Size	A Thread Unified	Max Conduit Size Table 2	Weight in Pounds Max.
01	.750 - 20	16	.035
02	1.000 - 20	24	.047
03	1.312 - 18	32	.062
04	1.500 - 18	40	.077
05	2.000 - 18	64	.104
06	.500 - 20	09	.030
07	.625 - 24	12	.031

Tubing Size	Conduit I.D.	J Dia Max
06	.188 (4.8)	.790 (20.1)
09	.281 (7.1)	.985 (25.0)
10	.312 (7.9)	.985 (25.0)
12	.375 (9.5)	1.035 (26.3)
14	.437 (11.1)	1.100 (27.9)
16	.500 (12.7)	1.160 (29.5)
20	.625 (15.9)	1.285 (32.6)
24	.750 (19.1)	1.480 (37.6)
28	.875 (22.2)	1.670 (42.4)
32	1.000 (25.4)	1.720 (43.7)
40	1.250 (31.8)	2.100 (53.3)
48	1.500 (38.1)	2.420 (61.5)
56	1.750 (44.5)	2.660 (67.6)
64	2.000 (50.8)	2.910 (73.9)

- APPLICATION NOTES**
- Metric dimensions (mm) are in parentheses and are for reference only.
  - Convulsed tubing to be ordered separately. See Type B, D and E.
  - Mates to 710-318, -319, -320 and -321 transitions
  - Coupling nut supplied unplated.



APPLICATION NOTES

1. Metric dimensions (mm) are in parentheses and are for reference only.
2. Convulsed tubing to be ordered separately. See Type E tubing.
3. Mates to 710-318, -319, -320 and -321 transitions
4. Coupling nut supplied unplated.

**712S271**  
**Composite Dual EMI/RFI Shield Termination**  
**Conduit Fitting**  
**For Glenair Series 74 Helical Convolved Tubing**



**TABLE I: CONDUIT FITTING SHELL SIZE**

Shell Size	A Thread Unified	Max Conduit Size Table 2	Weight in Pounds Max.
01	.750 - 20	16	.035
02	1.000 - 20	24	.047
03	1.312 - 18	32	.062
04	1.500 - 18	40	.077
05	2.000 - 18	64	.104
06	.500 - 20	09	.030
07	.625 - 24	12	.031

**TABLE II: TUBING SIZE**

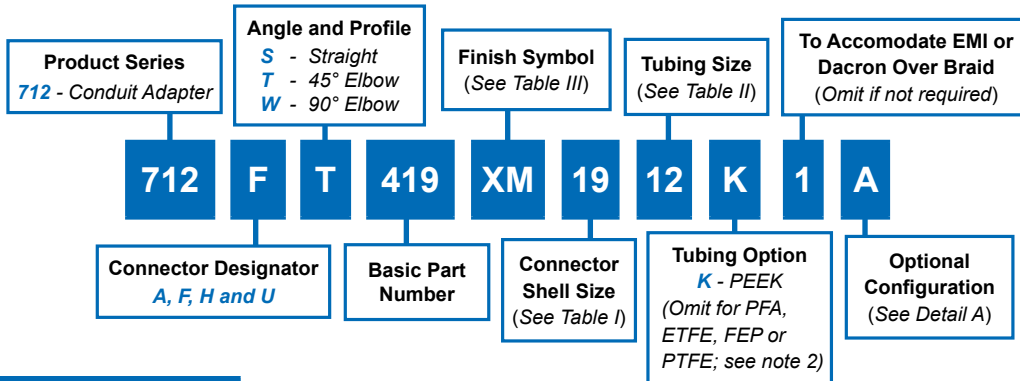
Tubing Size	Conduit I.D.	J Dia Max
06	.188 (4.8)	.790 (20.1)
09	.281 (7.1)	.985 (25.0)
10	.312 (7.9)	.985 (25.0)
12	.375 (9.5)	1.035 (26.3)
14	.437 (11.1)	1.100 (27.9)
16	.500 (12.7)	1.160 (29.5)
20	.625 (15.9)	1.285 (32.6)
24	.750 (19.1)	1.480 (37.6)
28	.875 (22.2)	1.670 (42.4)
32	1.000 (25.4)	1.720 (43.7)
40	1.250 (31.8)	2.100 (53.3)
48	1.500 (38.1)	2.420 (61.5)
56	1.750 (44.5)	2.660 (67.6)
64	2.000 (50.8)	2.910 (73.9)

C

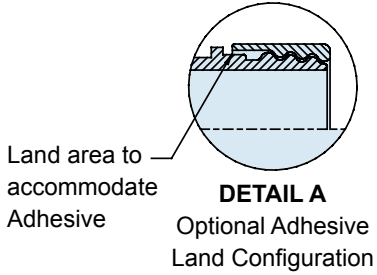
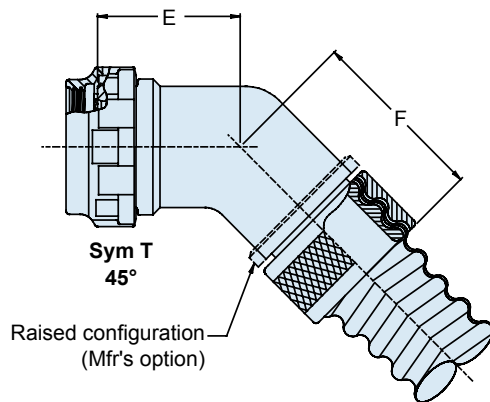
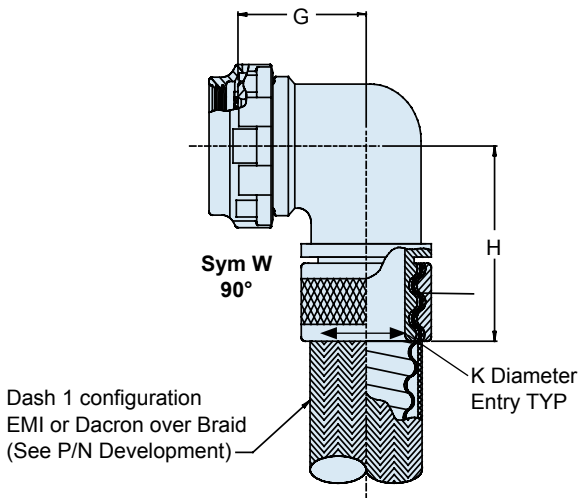
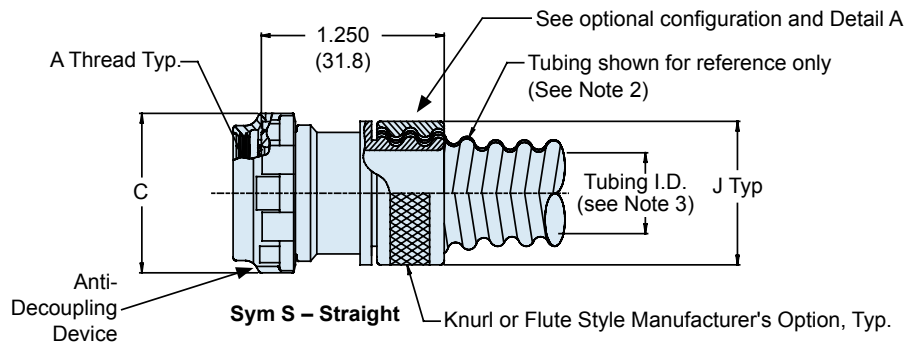
**TABLE III**

Symbol	Finish Description
XB	No Plating - Black Color (Non-Conductive Finish)
XM	2000 Hour Corrosion Resistant Electroless Nickel
XMT	2000 Hour Corrosion Resistant Ni-PTFE, Nickel-Fluorocarbon Polymer. <i>1000 Hour Grey™</i>
XO	No Plating - Brown Color (Non-Conductive Finish)
XW	2000 Hour Corrosion Resistant Cadmium/Olive Drab over Electroless Nickel

# 712-419 Composite Conduit-to-Connector Adapter Straight, 45° and 90° For Glenair Series 74 Helical Convuluted Tubing



CONNECTOR DESIGNATOR:	
<b>A</b>	MIL-DTL-5015 / -26482 / -83723
<b>F</b>	MIL-DTL-38999 Series I, II
<b>H</b>	MIL-DTL-38999 Series III and IV
<b>U</b>	DG123 and DG123A
<b>SELF-LOCKING</b>	
<b>ROTATABLE COUPLING</b>	
<b>LOW PROFILE</b>	





**712-419**  
**Composite Conduit-to-Connector Adapter**  
**Straight, 45° and 90°**  
**For Glenair Series 74 Helical Convulsed Tubing**



**TABLE I: CONNECTOR SHELL SIZE ORDER NUMBER**

Shell Size		E	F	G	H	Tubing
A, F & H	G & U	±.06 (1.5)	±.09 (2.3)	±.06 (1.5)	±.09 (2.3)	Size Max.
08, 09	–	.72 (18.3)	.89 (22.6)	.69 (17.5)	1.11 (28.2)	09
03, 10, 11	08	.75 (19.1)	.95 (24.1)	.75 (19.1)	1.16 (29.5)	12
12, 13	10, 11	.75 (19.1)	1.02 (25.9)	.81 (20.6)	1.22 (31.0)	16
14, 15	12, 13	.76 (19.3)	1.05 (26.7)	.88 (22.4)	1.29 (32.8)	20
16, 17	14, 15	.78 (19.8)	1.07 (27.2)	.94 (23.9)	1.35 (34.3)	24
18, 19	16, 17	.79 (20.1)	1.08 (27.4)	.97 (24.6)	1.38 (35.1)	28
20, 21	18, 19	.82 (20.8)	1.11 (28.2)	1.06 (26.9)	1.47 (37.3)	32
22, 23	20	.86 (21.8)	1.15 (29.2)	1.13 (28.7)	1.54 (39.1)	32
24, 25, 61	22, 23	.89 (22.6)	1.18 (30.0)	1.19 (30.2)	1.73 (43.9)	40
28	24, 25	.92 (23.4)	1.21 (30.7)	1.34 (34.0)	1.82 (46.2)	40

**TABLE II: TUBING SIZE**

Tubing Size	Conduit I.D.	J Dia Max	K Dia. Entry ± .03 (.76)
06	.188 (4.8)	.54 (13.7)	.12 (3.0)
09	.281 (7.1)	.63 (16.0)	.22 (5.6)
10	.312 (7.9)	.69 (17.5)	.24 (6.1)
12	.375 (9.5)	.73 (18.5)	.29 (7.4)
14	.437 (11.1)	.80 (20.3)	.34 (8.6)
16	.500 (12.7)	.87 (22.1)	.40 (10.2)
20	.625 (15.9)	1.00 (25.4)	.52 (13.2)
24	.750 (19.1)	1.18 (30.0)	.65 (16.5)
28	.875 (22.2)	1.32 (33.5)	.78 (19.8)
32	1.000 (25.4)	1.47 (37.3)	.90 (22.9)
40	1.250 (31.8)	1.76 (44.7)	1.08 (27.4)
48	1.500 (38.1)	2.13 (54.1)	1.32 (33.5)

**TABLE III**

Symbol	Finish Description
XB	No Plating - Black Color (Non-Conductive Finish)
XM	2000 Hour Corrosion Resistant Electroless Nickel
XMT	2000 Hour Corrosion Resistant Ni-PTFE, Nickel-Fluorocarbon Polymer. <i>1000 Hour Grey™</i>
XO	No Plating - Brown Color (Non-Conductive Finish)
XW	2000 Hour Corrosion Resistant Cadmium/Olive Drab over Electroless Nickel

**APPLICATION NOTES**

- Metric dimensions (mm) are in parentheses and are for reference only.
- Convulsed tubing size, tubing to be ordered separately (see Series 74 Catalog, Type A Tubing Section, Standard Pitch). Dash 1 configuration accommodates Type B or D Tubing. For PTFE maximum lengths - consult factory.
- Different adapters are necessary to terminate PEEK tubing. Nominal I.D. reduced by approximately .060 (use Suffix P) in P/N development. For permanent termination use 3M Scotch Weld after installing tubing/shielding, see Detail A.

# Glenair Composite Braid Doesn't Make the Fire Scout Fly...



## ...But It Sure Helps

When Northrop Grumman faced the challenge of reducing total system weight of the MQ-8B Fire Scout without sacrificing performance, they turned to their suppliers for help. Glenair suggested replacing the braided metal shielding used in the revolutionary aircraft with our lighter weight composite product. We explained the potential weight savings could be as much as 35% compared to the current base cable harness design, equipped with tin/

copper shielding. The integration of composite EMI/RFI braid would not only reduce weight, but also improve the system's corrosion resistance and durability—all at no added risk to sensitive electronic equipment.

As it turned out, the use of composite shielding reduced the main cable harness assembly by 12.5 Lbs.—not an insignificant amount when reduced fuel fractions and the ability to remain aloft for extended periods are key mission requirements.



1211 Air Way · Glendale, California 91201-2497

Telephone: 818-247-6000 · Facsimile: 818-500-9912 · E-mail: [sales@glenair.com](mailto:sales@glenair.com)

United States · United Kingdom · Germany · Nordic · France · Italy · Spain · Japan

[www.glenair.com](http://www.glenair.com)



## Glenair Composite Metal-Clad Lightweight AmberStrand® EMI/RFI Braided Shielding

For many applications, the cable shield is the most important element in controlling EMI. Unfortunately, metal shielding—especially when applied in multiple layers—can be extremely heavy. The opportunity to provide robust EMI shielding at a fraction of the weight is the principal advantage of composite thermoplastic braid made from AmberStrand® material. Transfer impedance test reports demonstrate the effectiveness of the material as compared to conventional metal solutions. Mechanical properties are comparable to other non-metallic materials (see Table I).

*Electrically Conductive*

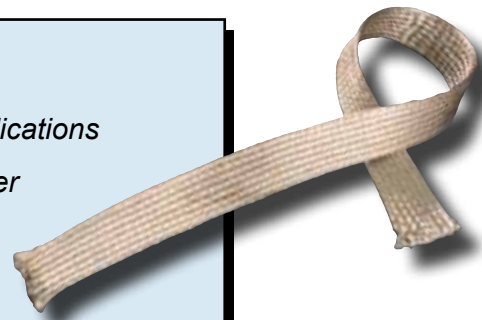
*Superior High Frequency Shielding in High Temperature Applications*

*Pure AmberStrand® and Blended AmberStrand®/Nickel Copper Configurations*

*Comparable Performance to 36 AWG Tubular Copper Braid*

*Lightweight, Corrosion-Free*

*100 Feet of 5/8" AmberStrand Vs. Tinned Copper Shield Saves 5+ Pounds*



**TABLE I: AMBERSTRAND® MECHANICAL PERFORMANCE COMPARED TO OTHER MATERIALS**

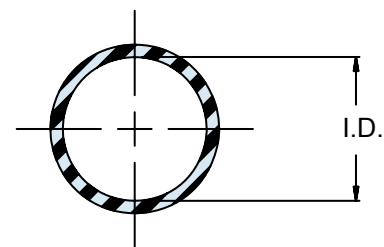
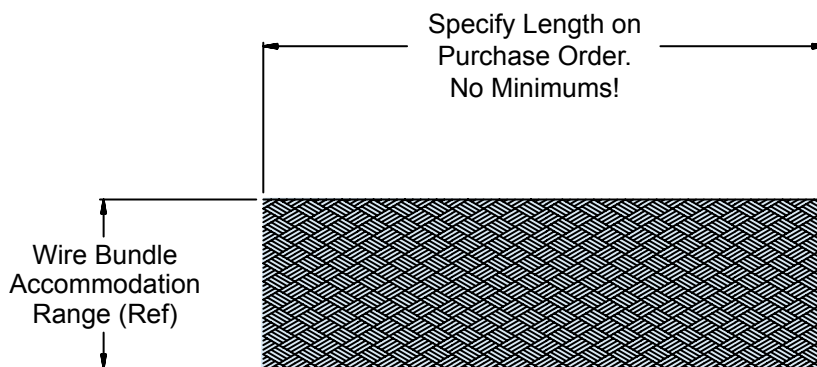
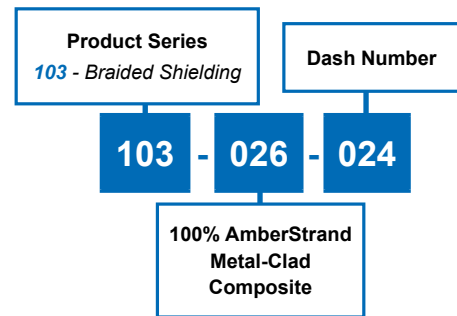
Material Type	AmberStrand® (Thermoplastic)	PEEK (Monofil)	Teflon (Yarn)	Kevlar (Yarn)	Dacron (Yarn)	Halar (Monofil)	Teflon FEP (Monofil)	Nomex (Yarn)	Polyester Type FR (Monofil)	Ryton Type R-7 (Monofil)
Glenair P/N	103-026 103-027	102-051	102-061	102-071	102-073	102-023	102-060	103-013	102-001 102-002	102-080
Temperature Range	-65° C to +200° C	-65° C to +260° C	-55° C to +260° C	-55° C to +200° C	-73° C to +175° C	-62° C to +150° C	-65° C to +200° C	-55° C to +260° C	-55° C to +125° C	-55° C to +200° C
Tensile Strength (PSI) Yield	590,000	780,000	40,000	400,000	160,000	35,000	14,000	90,000	50,000	19,000
Elongation %	2.5%	38%	19%	3.6%	12%	15%	50%	252%	20%	35%
Chemical Resistance	Excellent	Excellent	Excellent	Excellent	Good	Excellent	Excellent	Excellent	Good	Excellent
Abrasion Resistance	Good	Excellent	Good	Good	Excellent	Excellent	Good	Good	Good	Excellent
Specific Gravity	1.45	1.30	2.10	1.44	1.38	1.68	2.17	1.58	1.38	1.25
Flammability	Will Not Burn	Very Low	Will Not Burn	Will Not Melt	Flammable	Flammable	Very Low	Will Not Melt	Very Low	Very Low

\* Weight savings based on comparison to 36 AWG A-A-59569 tubular copper braid

**103-026**  
**100% AmberStrand® Composite Braid**  
**for EMI Shielding Applications**



TABLE I			
Dash Number	Nominal I.D. (Ref.)	Ref. Wire Bundle Range	Approximate Grams Per Foot
004	.125 (3.2)	.093 (2.4)	1.0
		.140 (3.5)	
008	.250 (6.4)	.125 (3.2)	1.8
		.312 (7.9)	
012	.375 (9.5)	.250 (6.4)	2.3
		.437 (11.1)	
016	.500 (12.7)	.250 (6.4)	3.7
		.375 (15.0)	
020	.625 (15.9)	.375 (9.5)	4.4
		.700 (17.8)	
024	.750 (19.1)	.500 (12.7)	5.2
		.830 (21.1)	
032	1.000 (25.4)	.780 (19.8)	8.0
		1.100 (27.94)	
040	1.250 (31.8)	.938 (23.8)	10.0
		1.312 (33.3)	
048	1.500 (38.1)	1.187 (30.1)	15.2
		1.590 (40.37)	
064	2.000 (50.8)	1.312 (33.3)	22.0
		2.090 (53.08)	

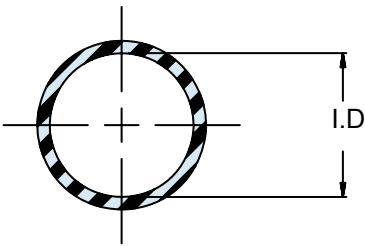
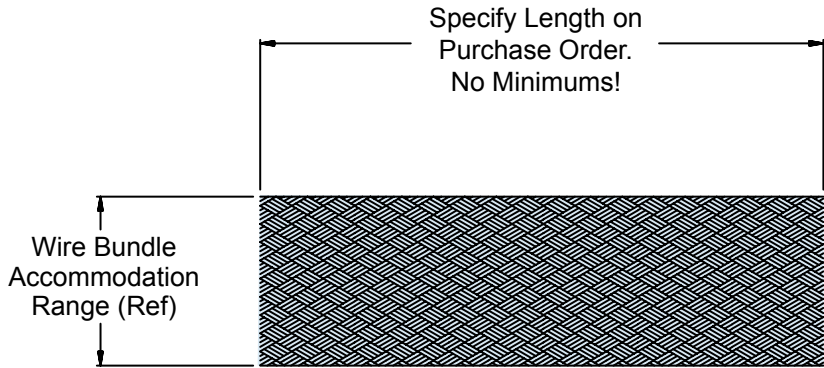
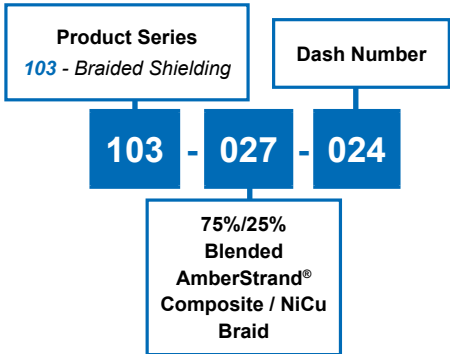


- APPLICATION NOTES**
1. Marking - Label individual packages.
  2. Material - Nickel Clad/Thermoplastic, silver color. Braid angle all sizes 40° - 50°
  3. Braid is made from Nickel-plated AmberStrand® composite thermoplastic fibers. AmberStrand® is a registered trademark of Syscom Advanced Materials, Inc.
  4. Metric dimensions (mm) are in parentheses and for reference only.

**103-027**  
**75% / 25% AmberStrand® Composite / NiCu Braid**  
**for EMI Shielding Applications**



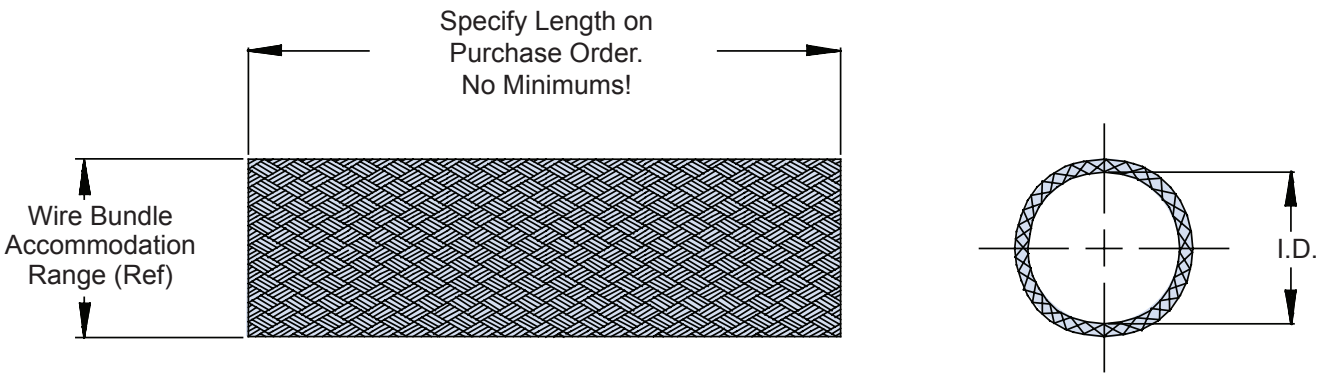
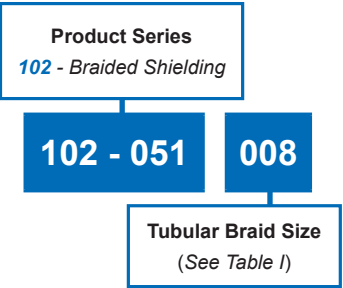
TABLE I			
Dash Number	Nominal I.D. (Ref.)	Ref. Wire Bundle Range	Approximate Grams Per Foot
004	.125 (3.2)	.093 (2.4)	1.5
		.140 (3.5)	
008	.250 (6.4)	.125 (3.2)	2.4
		.312 (7.9)	
012	.375 (9.5)	.250 (6.4)	3.9
		.437 (11.1)	
016	.500 (12.7)	.250 (6.4)	6.0
		.375 (15.0)	
020	.625 (15.9)	.375 (9.5)	6.4
		.700 (17.8)	
024	.750 (19.1)	.500 (12.7)	7.2
		.830 (21.1)	
032	1.000 (25.4)	.780 (19.8)	11.0
		1.100 (27.94)	
040	1.250 (31.8)	.938 (23.8)	15.0
		1.312 (33.3)	
048	1.500 (38.1)	1.187 (30.1)	25.2
		1.590 (40.37)	
064	2.000 (50.8)	1.312 (33.3)	32.0
		2.090 (53.08)	



D

- APPLICATION NOTES**
1. Marking - Label individual packages.
  2. Material - Nickel Clad/Thermoplastic, silver color.  
Nickel plated Copper wire/ASTM B355 CL.7 OFHC, 36 awg  
Braid angle all sizes 40° - 50°
  3. Consult factory for alternative blend ratios.
  4. Braid is made from Nickel-plated AmberStrand® composite thermoplastic fibers. AmberStrand® is a registered trademark of Syscom Advanced Materials, Inc.
  5. Metric dimensions (mm) are in parenthesis and for reference only.

# 102-051 PEEK Tubular Braid (Black) for Series 74 Convoluted Tubing



## D

Table I			
Part No.	Nominal I.D.	Wire Bundle Accommodation Range Ref.	
		Min.	Max.
<b>102-051-004</b>	.125 (3.2)	.125 (3.2)	.187 (4.7)
<b>102-051-008</b>	.250 (6.4)	.250 (6.4)	.360 (9.1)
<b>102-051-012</b>	.375 (9.5)	.312 (7.9)	.430 (10.9)
<b>102-051-016</b>	.500 (12.7)	.375 (9.5)	.600 (15.2)
<b>102-051-024</b>	.750 (19.1)	.500 (12.7)	.810 (20.6)
<b>102-051-040</b>	1.250 (31.8)	.750 (19.1)	1.312 (33.3)
<b>102-051-064</b>	2.000 (50.8)	.937 (23.8)	2.187 (55.5)
<b>102-051-080</b>	2.500 (63.5)	1.125 (28.6)	2.687 (68.2)

**APPLICATION NOTES**

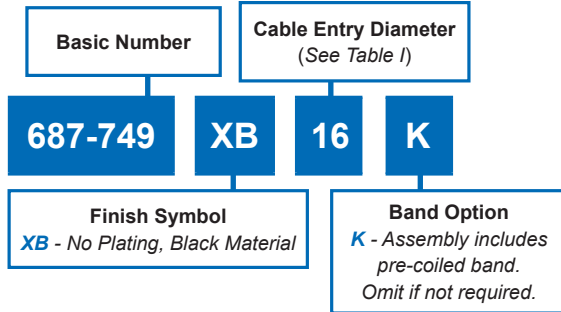
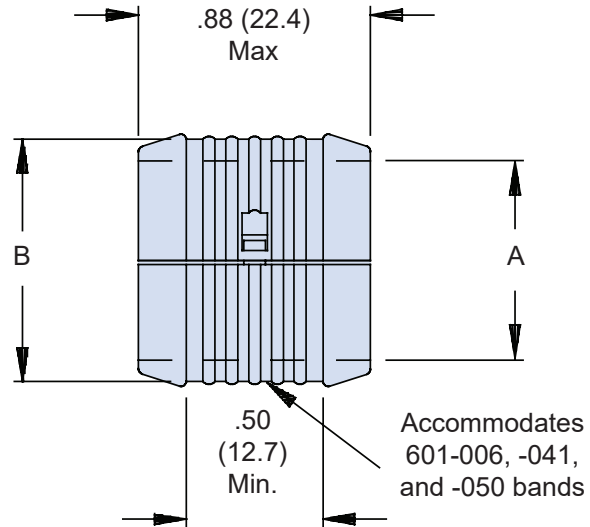
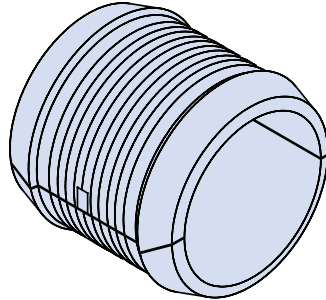
1. Metric dimensions (mm) are in parentheses and are for reference only.

**687-749**  
**Composite AS85049/93**  
**Banding Split-Ring**



For Use with Glenair  
Banding Backshells  
and Braid Socks

Consult Factory for  
Information on Other  
Split Ring Designs and  
Part Numbers



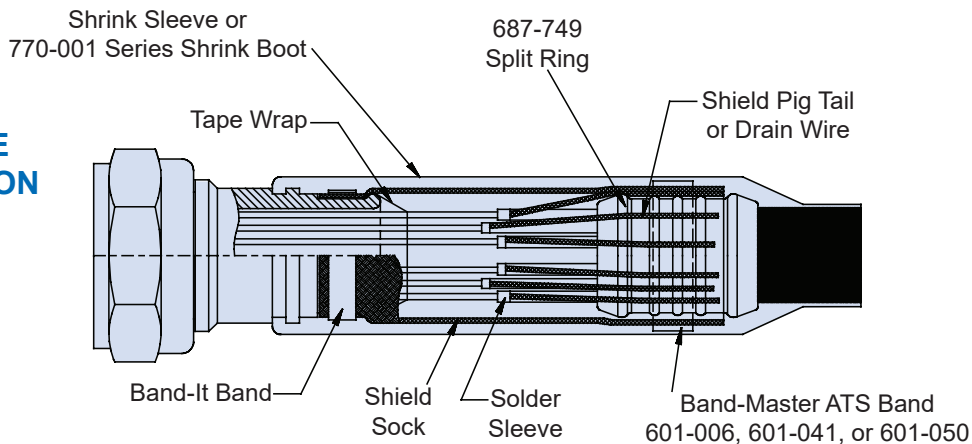
**TABLE I: DASH NUMBER**

Dash No.	A Diameter ± .03 (0.8)	B Diameter ± .03 (0.8)	Compatible Glenair Band
04	.25 (6.4)	.36 (9.1)	601-006
06	.38 (9.7)	.49 (12.4)	601-006
08	.50 (12.7)	.61 (15.5)	601-006
10	.63 (16.0)	.74 (18.8)	601-006
12	.75 (19.1)	.86 (21.8)	601-006
14	.88 (22.4)	.99 (25.1)	601-041
16	1.00 (25.4)	1.10 (27.9)	601-041
18	1.13 (28.7)	1.24 (31.5)	601-041
20	1.25 (31.8)	1.36 (34.5)	601-041
22	1.38 (35.1)	1.49 (37.8)	601-041
24	1.50 (38.1)	1.61 (40.9)	601-041
26	1.63 (41.4)	1.74 (44.2)	601-041
28	1.75 (44.5)	1.86 (47.2)	601-050
30	1.88 (47.8)	2.00 (50.8)	601-050
32	2.00 (50.8)	2.13 (54.1)	601-050
36	2.25 (57.2)	2.38 (60.4)	601-050

**APPLICATION NOTES**

- 687-749 supersedes and replaces 687-207 split ring.
- Metric dimensions (mm) are in parentheses and are for reference only.

**EXAMPLE APPLICATION**





*Glenair Announces:*

# 140 Series EMI/RFI Composite Boxes

*Now NAVSEA Approved for use on U.S. Naval Ships*

## NAVSEA Approved Composite Electrical Enclosures Junction Boxes - Electrical Boxes - Sound-Powered Phones

### NAVSEA Approval:

Glenair advanced, corrosion-control composite electrical boxes are now NAVSEA approved for deployment around the fleet. All testing has been completed and NAVSEA is working with NAVSUP Mechanicsburg to introduce the individual boxes and replacement parts to the stock system. For NAVSEA contact information or for the latest procurement information on the NAVSEA 803-6983506 drawing please contact Glenair @ 818-247-6000.

**Glenair salutes** and extends its thanks to the many officers and sailors who participated in sea trails to evaluate and perfect the NAVSEA composite box conversion project, including the men and women of the:

- USS Geo. Washington (CVN-73)
- USS Theo. Roosevelt (CVN-71)
- USS Barry (DDG-52)
- USS Comstock (LSD-45)
- USS Vella Gulf (CG-72)
- USS Rushmore (LSD-47)
- USS Enterprise (CVN-65)
- USS D. D. Eisenhower (CVN-69)
- USS Curtis Wilbur (DDG54)
- USS John S. McCain (DDG56)
- USS Whidbey Island (LSD-41)
- USS Germantown (LSD-42)
- USS Fort McHenry (LSD-43)
- USS Harpers Ferry (LSD-49)
- USS Pearl Harbor (LSD-52)

How to Order			
Box/Part Type	National Stock Number (NSN)	Glenair Series Part Number	Navy Symbol Number Ref.
<b>Junction Boxes</b>			
Small Round	5975-01-556-7948	140-060XMS-05	-
Small Rectangular	5975-01-556-7957	140-060XMS-01	-
Medium Rectangular	5940-01-557-2672	140-060XMS-02	-
Large Rectangular	5940-01-557-2679	140-060XMS-03	-
<b>Electrical Boxes</b>			
Single Gang	5940-01-557-2645	147-023XMS-01	735.3
Single Gang	5940-01-557-2667	147-023XMS-02	1099.1
Single Gang	5940-01-557-2725	147-033XMS-0003	1098.1
Single Gang	5940-01-557-2719	147-032XMS-0005G	1101
Dual Gang	5975-01-556-9504	147-020XMS-02	-
Dual Gang	5940-01-557-2634	147-020XMS-05	-
<b>Sound Powered Phone Box</b>			
Single Gang	5975-01-556-9617	147-022XMS-01	2841
Dual Gang	5975-01-556-9572	147-021XMS-02	2842
Quad Gang	5940-01-557-2639	147-021XMS-03	2843
<b>Terminal Boxes</b>			
Small Round	5940-01-557-2579	140-060XMS-05T2	5201
Small Round	5940-01-557-2712	140-060XMS-05T4	400
Small Rectangular	5975-01-556-7967	140-060XMS-01T3	435.1
Small Rectangular	5975-01-556-9434	140-060XMS-01T4	528
Small Rectangular	5975-01-556-9443	140-060XMS-01T6	444
Large Rectangular	5975-01-556-9489	140-060XMS-03T1	432.1
Large Rectangular	5940-01-557-2564	140-060XMS-03T2	434
Large Rectangular	5940-01-557-2578	140-060XMS-03T5	529
Large Rectangular	5940-01-215-5963	140-060XMS-03T9	433.1
Large Square	—	140-060XMS-06T1	522.1
Large Square	—	140-060XMS-06T2	446
Large Square	—	140-060XMS-06T3	525
<b>Replacement Parts and Fittings</b>			
Composite Feedthrough Adapter*		637B094XB02102CB	-
Composite Sound-Power Receptacle Connector		227-059XO04W	-
Replacement Sound-Power Flop Lid Cover Assembly		630-038XO-02K	-
Replacement Electrical Flop Lid Cover Assembly		630-038XO-01K	-
Replacement Collar Mate Flop Lid Assembly		630-038XO-04K	-
Replacement Cover Screwkit		687-499-1	-
<b>Turnkey Box/Panel Assemblies</b>			
LSD41 Class Ship Stern Gate Control Panel Assembly		149-003	-
LSD49 Class Ship Stern Gate Control Panel Assembly		149-004	-
CVN Nimitz Class Elevator Control Communication System		147-038XMS-002	-
LSD41 and LSD49 LCAC Docking Light Panel		149-005	-

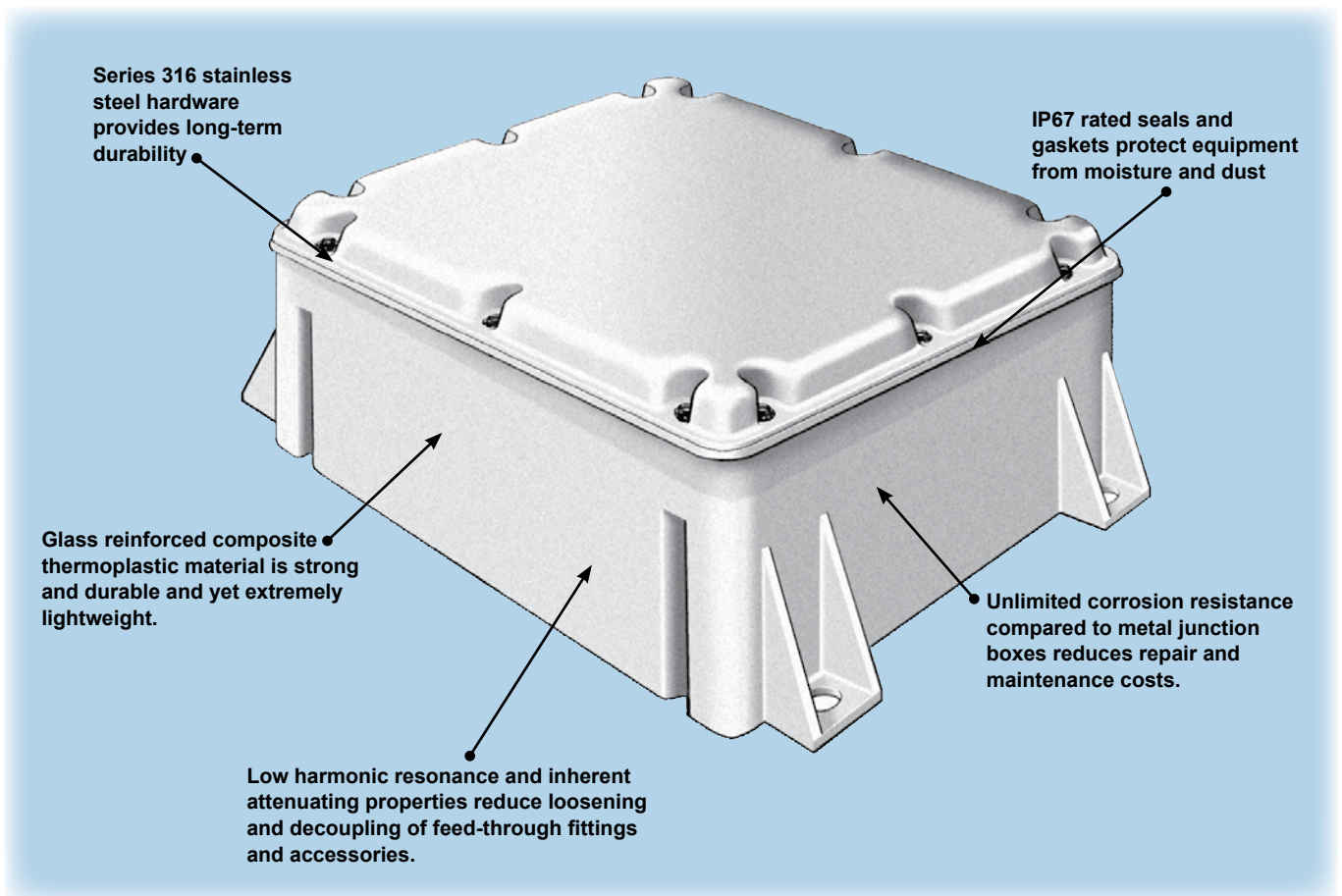


# Lots of Junction Boxes are Built for use in Harsh, EMI/RFI Applications. Ours are Built to Save You Money.

**G**lenair is the recognized leader in composite thermoplastic research and development for the interconnect accessory industry. Glenair's lightweight/high-strength CostSaver Composite EMI/RFI Junction Boxes are ideally suited for use in harsh environments where resistance to electromagnetic interference, corrosive fluids,

high temperatures, shock and vibration is a critical requirement.

The boxes are designed to meet the shock and vibration requirements of MIL-S-901D and MIL-STD-167SHIPS. Box materials also meet stringent EMI/RFI/HIRF and indirect lightning strike performance specifications.



## Step One: Specification of a Junction Box Assembly Begins with the Selection of the Right Size Box—Both in Terms of the Internal Volume and the External Package Size.

**G**lenair's CostSaver Composite Junction Boxes are ideally suited for use in harsh environments where weight savings and resistance to electromagnetic interference, corrosive fluids, high temperatures, shock and vibration are critical requirements.

Compared to aluminum, brass or steel boxes, Glenair's "CostSavers" provide equal or improved RFI/EMI protection, with considerable savings in corrosion-related maintenance.

Glenair boxes are outfitted with captive stainless steel cover screws for additional long-term corrosion resistance.

In retrofit applications, select the most efficient size to fit the existing electronics package. More than one box can sometimes be used efficiently if the electronics package can be split between two or more boxes. For new application designs, please consult the factory for advice on maximizing the use of internal package space.



### **Small Three-Legged Box (Series 140-106)**

The latest box design from Glenair is ideally suited for reduced package-size junction box applications such as LED lighting, switches and other single component applications. Designed to accommodate a 3.5 inch internal mounting plate, the three-legged box is currently in use in a wide range of US Navy applications. Three sides of the hexagonal box, as well as the lid, can accommodate bulkhead fittings. Materials and performance ratings are identical to the other boxes in the Glenair composite box line.

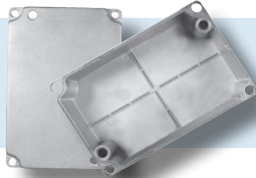
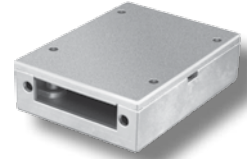
### **Multi-Port Split Shell Box Series**

Glenair now produces two configurations of multi-port split shell composite thermoplastic junction boxes, our 140-200 octagonal design box and our 140-203 twelve port rectangular box. Both designs are equipped with 316L stainless steel fasteners for corrosion resistance. The split-shell design affords easy access for maintenance or access to stored cable loops.



**Ultra-Miniature Junction Box (Series 140-074)**

Glenair's smallest and lightest box and is designed for non-environmental module-to-chassis applications using MTC connectors. Cover snaps in place without the use of fasteners.

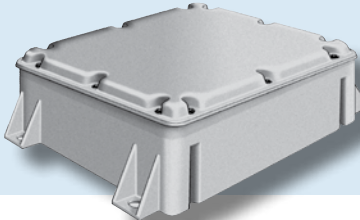


**Mini Junction Box (Series 140-100)**

Typically used in controlled (non-environmental) applications (such as instrument cases) or as a junction box for miniature connectors.

**Small Junction Box (Series 140-101)**

Designed for use in harsh environmental applications (shipboard weather deck, up-mast, etc.) which require EMI/RFI protection and resistance to vibration and shock.

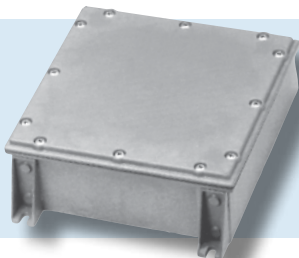
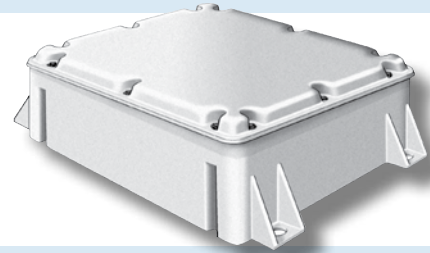


**Medium Junction Box (Series 140-102)**

Used in high-performance military and commercial applications as a terminal block enclosure, interconnect junction box or instrument case. Size is suitable for larger shell size connectors and fittings.

**Large Junction Box (Series 140-103)**

This large volume box is geared for cable storage and for use in large electrical and optical interconnect junctions. Top and side surface area accommodate large numbers of circular and rectangular connectors and fittings.



**Small Low-Profile Junction Box (Series 140-104)**

Ideal for use in limited size and space applications, this composite box is geared for fiber optics and other miniaturized interconnect components. The box has been used extensively in high-performance air and space retrofit applications

**Medium Low-Profile Junction Box (Series 140-105)**

This low-profile box is geared for tight spaces, such as under-seat cockpit and in-flight-entertainment systems. The box features three (optional) internal dividers for increased isolation of radiated EMI.



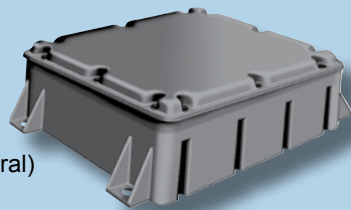
**Jumbo Junction Box (Series 140-107)**

This extra large box is geared for terminal junctions as well as integration of large pieces of electronic and electrical equipment.

## Step Two: Select Box Color, Plating and Plating Coverage

**Color:** Color pigments may be added directly to the polymer to create a limited range of standard color options. Currently Glenair offers the following box color selections:

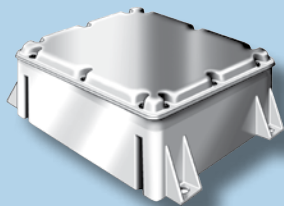
- Black
- Blue
- Grey
- Brown (Natural)
- Purple



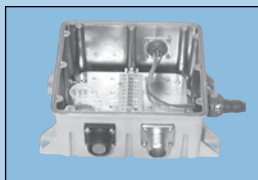
Certain industries and applications have standardized on particular colors and Glenair can provide custom colors as necessary. Colors may affect material performance. For exact matching of custom colors please provide the factory with a PMS color chip number or material sample.

**Plating:** Glenair offers three standard plating options for EMI/RFI applications:

- Electroless Nickel
- Ni-PTFE
- No Plating, Customer Choice of Base Color



**Plating Coverage:** Plating may be applied selectively to meet specific EMI/RFI shielding and grounding requirements (Unplated models are selected when the grounding of interconnect components for EMI protection is not required). Internal plating with selectively plated penetrations provides optimal EMI protection and surface durability (scratch resistance) External Plating provides complete electromagnetic compatibility without the cost of selective masking and plating.



Internal Plating Only



Selective Plating

## PEI\* Resin Withstands Long-Term Exposure to Heat, Moisture and Caustic Chemicals

Glenair CostSaver Composite Boxes are made from PEI, 30% glass fiber, (polyetherimide). PEI is an amorphous thermoplastic polyetherimide offering outstanding high heat resistance, high strength, modulus and broad chemical resistance. Its balance of properties and processability offers design engineers exceptional flexibility and freedom to innovate. PEI resins are inherently flame resistant with low smoke emission. It is radiation resistant, microwave transparent and is naturally flame retardant. Because of its unequaled properties, PEI is the ideal replacement for steel and other metals. PEI resins offer: inherent flame resistance, long-term heat resistance, dimensional stability, strength and modulus at elevated temperatures, hydrolytic and chemical stability, and environmental and corrosion resistance.

### Environmental Properties

PEI resin is resistant to mineral acids, mineral salt solutions and dilute bases. Unlike other amorphous resins, PEI polyetherimide also demonstrates unusually good resistance to a wide range of caustic chemicals.

PEI resin is unaffected by most hydrocarbons, making it an excellent candidate for aircraft and shipboard applications exposed to gasoline, oils and other fuels.

PEI resin is inherently resistant to UV radiation without the addition of stabilizers. Exposure to 1000 hours of Xenon arc weatherometer irradiation (1.55 Watts/m<sup>2</sup> irradiance at 340 nm, 63°C) produces a negligible change in the tensile strength of the resin.

PEI resin exhibits excellent hydrolytic stability of tensile strength after immersion in water. 10,000 hour immersion tests in water at 212°F (100°C) show that PEI resin's physical properties remain virtually unchanged, even with repeated cycling from steam pressure to drying in vacuum at room temperature.

\*G.E. ULTEM® Resin

## Thermal Properties

An outstanding property of PEI resin is its ability to withstand long-term exposure to elevated temperatures. This high-heat performance, combined with excellent flammability ratings and UL recognition, qualifies PEI resin for demanding high temperature applications. UL rates PEI resin for continuous use at 170°C. The resin's high glass transition temperature, T<sub>g</sub>, of 419°F (215°C), coupled with its high heat deflection temperature of 392°F (200°C) at 264 psi (1.82 N/mm<sup>2</sup>), contributes to its excellent retention of physical properties at elevated temperatures.

The coefficient of thermal expansion is an important design consideration in the production of large composite enclosures, fittings and mating connectors. The table below lists the coefficients of thermal expansion for PEI and the matching values for various metals:

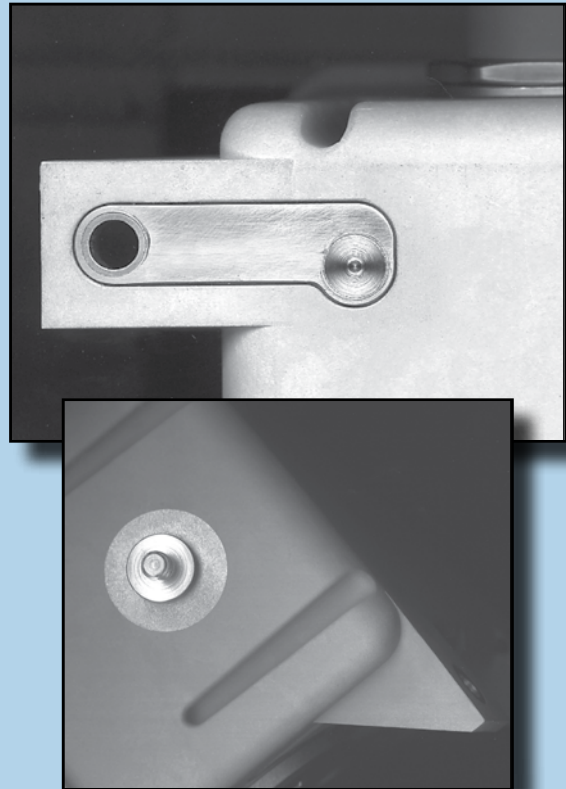
### Coefficient of Linear Thermal Expansion

Material	10 <sup>-5</sup> in/in -°F	10 <sup>-5</sup> m/m -°C
PEI	1.1	2.0
Brass	0.4 - 1.0	1.6-1.8
Zinc	1.5	2.7
Aluminum	1.2	2.2
Steel	0.7-0.8	1.2-1.5

## Strength

At room temperature PEI resin exhibits strength far beyond that of most engineering thermoplastics, with a tensile strength yield of over 15,000 psi (100 N/mm<sup>2</sup>) and a flexural strength at 5% deflection of 21,000 psi (145 N/mm<sup>2</sup>). Even more impressive is the strength at elevated temperatures. At 375°F (190°C), a temperature well beyond the useful range of most other engineering thermoplastics, PEI retains approximately 6,000 psi (41 N/mm<sup>2</sup>) tensile strength. The inherent strength of PEI is increased by reinforcement with glass fibers, such as the 30% fiber mix used by Glenair.

## Step Three: Select the (Optional) Grounding/Earthing Device



### Choose from Two Standard Grounding Device Designs

MIL-STD-1310G (NAVY) requires that electrical equipment operated from an external power source be grounded to provide electrical safety and personnel shock protection. Glenair's integrated grounding foot (top photo) combines the earthing function into one of the box mounting feet; thus eliminating the need for an additional, external grounding strap and mounting point.

The simple grounding stud (bottom photo) is an inexpensive and yet effective way to provide overall grounding of the box. Typically, a wire grounding strap is fixed to the stud and taken to ground on an adjacent bulkhead. The threaded stud penetrates the box for easy attachment of an internal ground wire.



# Glenair Composite Boxes, Connectors and Accessories Test Plan

## **Plating Adhesion Glenair# 9-44-18/TN94-159**

The item is tested in accordance with MIL-DTL-38999 and should not exhibit any blistering, peeling or other separation of the units plating when immersed in ice water at 0°C within 15 seconds after 30 minutes exposure to 200°C in a circulating oven.

## **Vibration NTS# 973-7369-2**

When mounted in a suitable fixture on a vibration table and subjected to vibration in accordance with MIL-STD-167 type 1 for box units & Mil STD-1344, Method 2005 Condition III, for fittings and accessories. The tested items should not exhibit loosening of component parts or evidence of damage.

## **Shock NTS# 973-7369-2**

When mounted on an Impact plate the Glenair Box is subjected to shock load (Hammer drop) in accordance with MIL-STD-901D, Lightweight, Grade C, there shall be no loosening of parts or evidence of damage. A 400 LB hammer weight attached to a 5 foot long swing arm is raised and released to strike the mounting plate, 9 blows (3 blows in 3 axes).

## **Shock MOD# BR8470 Grade C & F**

Glenair box is mounted on a suitable fixture and subjected to an initial 70G load progressing to 130G load in accordance with MOD BR 8470 Grade C & F, there shall be no loosening of parts or evidence of damage.

## **Salt Spray Glenair# 9-44-18/TN94-159**

The item shall meet Braid Retention, Device conductivity, functional requirements and exhibit no exposure of underplate or base material when subjected to 2000 hrs per MIL-STD-1344 Method 1001.

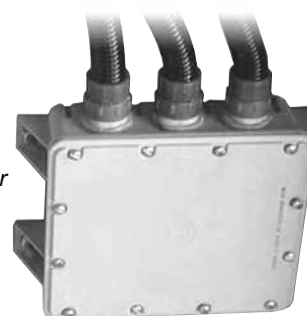
## **Dust NTS# 973-7369-1**

The item must conform to required torque limits and functional requirements within 25% after being subjected to sand and dust test of MIL-STD-202 Method 110.

## **UV Light Resistance GE RDM88050255-6042**

There shall be no degradation of the mechanical properties defined in this specification after testing in accordance with ASTM D2565

*Glenair's 140-060 Series Junction Box for the US Navy is available in four sizes and is supplied either with or without terminal rails and blocks. (See Page E-16)*



## **Impact**

There shall be no evidence of breaking or cracking of components or other damage, which could affect the product performance. The box will be tested in accordance with MIL-STD-1344 Method 2015 using 8 drops from a height of 2 meters with plate indexed at 36° intervals.

## **External Bending Moment Glenair# 9-44-18/TN94-159**

No evidence of damage detrimental to normal operation when subjected to 3X magnification after being subjected to loads specified in MIL-STD-1344.

## **Temperature Cycling NTS# 575-9249**

Item is subjected to a controlled temperature in accordance with MIL-Std-1344 Method 1003 @ -65°C to 200°C. After testing the product must not exhibit any cracking, peeling or separation of plating, or other functional damage.

## **Hydrolytic Stability NTS# 878-536**

In accordance with ASTM D570-81, Tested Items shall be free of defects detrimental to mechanical performance, no increase in weight greater than 1% and no evidence of cracking, breaking or loosening of component parts when subjected to boiling water.

**Ice Resistance Glenair# 9-44-18/TN94-159**

The item must conform to required torque limits and functional requirements within 25% after being immersed for a minimum of 3 cycles in tap water for 1 minute and placed in an ambient temperature of -65°C for one hour (until surfaces are completely iced over).

**Flammability**

The item flame and after flow-extinguishing time shall not exceed limits defined in Table II of MIL-STD-1344 Method 1012, Smoke index, NES 711 issue 2, and NES 713 issue 3. Burning behavior by Oxygen index, ISO 4589.

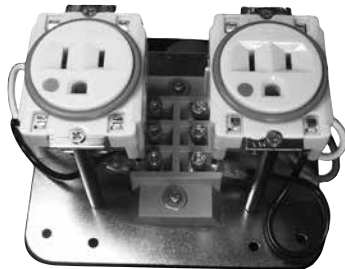
**Water Tightness EA# 0C13513-039514**

Water tightness and internal pressurization tested at 1 atmosphere (14.7 psi). Unit is subjected to a progressive internal pressure test in three feet of water at ambient temperature in increasing increments of 1psig for 2-minute intervals.

**Outgassing JPL 081892**

Unit is tested in accordance with ASTM E 595; maximum allowable weight loss is 10%. After test and bake out the maximum allowable VCM (volatile condensable material) is 0.10%.

*Electrical equipment ready for installation in Glenair's 147-020 Series Electrical Box for the U.S. Navy*

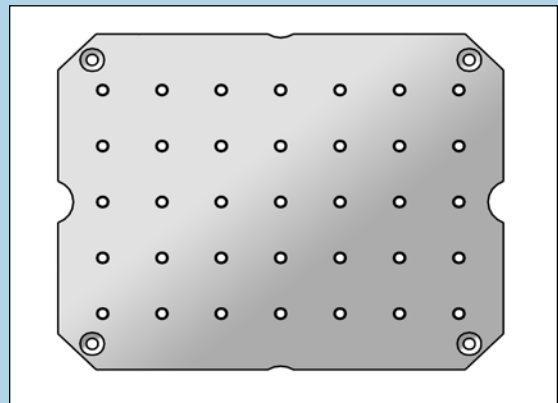


**Electromagnetic Shielding TRW/ABQ-55C-1186-0**

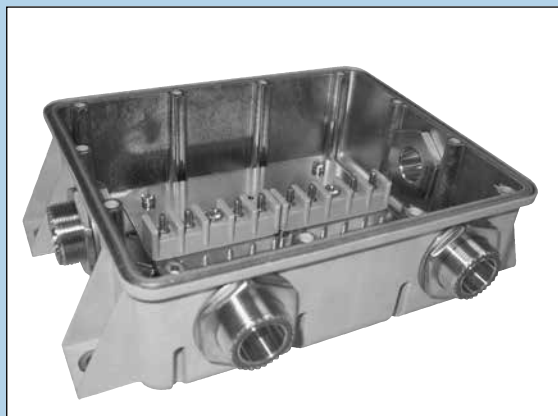
Shielding effectiveness / transfer impedance tests performed in accordance with Military industry standards and customer specific requirements. Transfer impedance measurements from 1 through 100 MHZ and radiated emissions were evaluated in the ranges from 20 through 1000 MHZ. The test specimen is subjected to an EMI field and measured to determine to specific levels of shielding properties are exhibited.

Step Four: Select Internal Terminal Rail Mounting Plate and Drilling

Glenair manufactures an internal terminal rail mounting plate for all box sizes except the Ultra-Miniature (140-074) and Mini (140-100). Terminal rail mounting plates are fabricated from aluminum alloy or stainless steel and are typically passivated or plated with electroless nickel. Custom platings are also available. The factory maintains dimensional specifications for all popular din rail and terminal block types and can drill plates per these specifications or to your drawing. Please consult factory for mounting options for nonstandard electronic components.

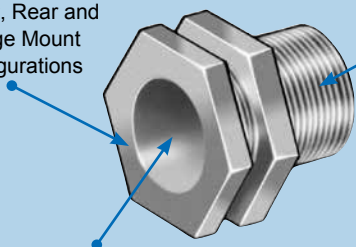


The Standard Plate Selection for Each Box Comes with Threaded Inserts for Most Popular Terminal Rails or Blocks



## Step Five: Select Box Input-Output Components: Feed-Through Fittings

Front, Rear and  
Flange Mount  
configurations



Optional end-  
fittings include  
Banding Adapter  
Platforms, Shrink  
Boots and  
Strain-Reliefs

Designed for use with all types of shielded and unshielded cable and conduit, from less than 1/4" to 1 3/4" in diameter

Glenair manufactures a full spectrum line of feed-through fittings for routing wire, cable and conduit into and out of switch gear and other types of junction boxes. The fittings are also ideal for thru-panel and bulkhead applications.

From environmental sealers and EMI/RFI shield terminators to strain reliefs and shrink boot adapters—Glenair has the right box feed-through for every application requirement.

Stainless versions are available in every configuration, but as a design consideration, composite feedthroughs should be considered for all applications where weight savings and extended corrosion protection is desired. Our composite thermoplastic designs (component series 637-094) offer significant weight savings over stainless steel and, again, unlimited corrosion protection. Many of our most popular part numbers are in stock, in quantity and ready for immediate delivery.

It is particularly important not to specify aluminum alloy fittings for harsh environment box applications. Compared to aluminum alloy, Glenair composite fittings provide equal or improved RFI/EMI protection, and are made from the same high-grade ULTEM® engineering thermoplastic as our boxes. Composite feedthroughs are designed to meet RTCA/DO-160C environmental conditions and physical strength requirements. Please consult the factory for assistance in selecting the best materials and platings for your application.

### **Braid Retention Glenair# 9-44-18/TN94-159**

Fitting terminations shall be capable of providing 2.5 milliohms maximum resistance between braid and fitting interface when braid is subjected to a tensile load of 5 Kg applied gradually.

### **EMI Shielding MOD# ME1A24S136F**

Shielding effectiveness Shipboard in accordance with M.O.D. Def Standard 59-41 DRE01. The Glenair box is subjected to an EMI field and measured to the level of shielding effectiveness per the Def standard 59-41 DRE01.

### **Indirect Lightning (Lightning Strike) LT# LT-95-1153, LT-00-1752**

Testing in accordance with MIL-STD-1344. Item is subjected to Waveform 1 & 5B using a high current generator. The item must remain functional without degradation of unit's electrical performance. Waveform 1 and 5B are applied starting at 3ka increasing to 20ka checking continuity measurements at set intervals. Waveform 1 will additionally be subjected to an oscillatory wave starting at 30ka and increasing in 10ka steps until failure in continuity measured.



**Glenair 147-021 and 147-022 Series Sound Powered Telephone Boxes for the US Navy are available in three box sizes with custom single, dual or quad jack receptacles**

### **Humidity NTS# 575-9249**

The test specimen is subjected to the humidity test specified in MIL-STD-1344 Method 1002 Test Condition Type II. The tested item shall exhibit no weight increase, swelling or other evidence of moisture absorption into the base material.



### Fungus Resistance TBM84-3

Materials used shall be certified as fungus inert in accordance with requirements of MIL-STD-810C, Items must have no evidence of Fungus growth, deterioration or corrosion as a result of testing.

### Shock NTS# 373-2685, Supplement 1

When mounted on an uneven surface with one mounting location lower to create torsion loading, box is subjected to shock per MIL-S-901D Class 1, Grade A, Type C (lightweight).

Glenair 147-015 Series Indicator Light Box is available in four sizes and supplied with US Navy specified indicator lights and switches



### Magnetic Permeability Glenair# 9-44-18/TN94-159

Items shall be tested in accordance with MIL-STD-1344.

### Ozone NTS# 678-3143

There shall be no evidence of cracking or other damage when item is tested in accordance with MIL-STD-1344 Method 1007.

### Fluid Immersion NTS# 678-3143

Item shall meet the functional requirements in accordance with MIL-STD-1344 Method 1016 (one sample per fluid).

### Halogen Free GE 050198

Testing for halogen releases when ignited in accordance with ASTM XX,

### Radiation Test GE RDM88050255-6042

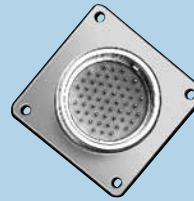
Gamma Ray, Electron Beam, X-Ray, Ultra Violet, Visible, Infrared, Microwave and Radio Frequency testing performed.

### Fitting to Box Conductivity NTS# 575-9249

Max. Voltage drop of 3 millivolts before conditioning and 6 millivolts after conditioning when tested to MIL-STD-1344 Method 3007.

## Step Six: Select Box Input-Output Components: Environmental Connectors

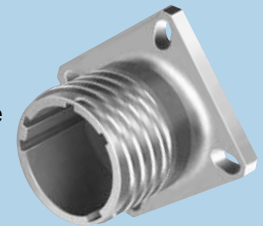
Glenair offers a wide range of circular and rectangular connectors, including MIL-DTL-28840, MIL-PRF-83513 and MIL-DTL-38999 Hermetics. Environmental connectors of this type, and the ones highlighted below, are ideally suited for use as input-output devices in box applications.



**Glenair's Series 22 Geo-Marine® Connectors** offer high-density insert arrangements for a variety of oceanographic, geophysical and other severe environmental applications. The mated stainless steel plug and receptacle have a hydro-

static pressure sealing capability of up to 5000 psi (345 bar) and are available in either glass-seal hermetic or rigid dielectric environmental insulators.

**Glenair's Composite MIL-DTL-38999 Series III Style Fiber Optic Connector** is built to insure precise optical alignment. Composite materials make this one of the lightest weight, high-reliability connectors on the market. Connector polarization keys and keyways are molded to tighter tolerances than required by the MIL-DTL-38999 specification to reduce radial misalignment and insertion loss.



Glenair developed the **Series 800 "Mighty Mouse"** to fill the need for a miniaturized circular connector with performance comparable to other high-reliability aerospace connectors. The connector is intended for applications such as missile systems, satellites, man-portable battlefield gear, and light armored vehicles. It is ideally suited for use with Glenair's smaller junction boxes.

## Step Seven: Select Wire and Cable Construction—From Convoluted Tubing to Armored and Overmolded Cable Designs



*The Widest Range of Protective Materials in the Industry are Available From Glenair*

Depending on your selection of input-output devices—from simple wire feed-through fittings to environmental connectors—Glenair can outfit the junction box assembly with an appropriate cable or conduit design. Tested and qualified products, including a broad range of environmental jacketing and shrink-boot materials are available for standard cable-to-connector designs. Glenair can also supply overmolded cables for harsh environments made from polymer compounds such as Viton®, Neoprene and Polyurethane.

Given the need to complete final installation of the box interconnect system on-site, many customers specify plastic and metal-core convoluted tubing as their preferred media protection material. Flexible, high-temperature convoluted tubing is an ideal material choice for interconnect systems designed around the Glenair junction box. The material provides a durable, highly-flexible enclosure for all types of wires. And Glenair is able to supply the all the end-fittings and transitions necessary to meet any installation configuration. Available materials include ETFE, FEP, PFA, PTFE and halogen-free, light weight PEEK. Glenair conduit, systems and fittings are approved to the US Navy's MIL-PRF-24758 standard. Our new FIRST Conduit Fitting System features a unique swivel design for easy installation.

## Relevant Industry Standards:

### IEC IP Ingress Ratings

The IP Rating indicates the measure of an enclosure's protection against dirt and water. Glenair CostSaver Composite EMI/RFI Boxes are rated to IP 67, where 6 = Total Protection Against Solid Objects, and 7 = Protection against the effects of temporary immersion in water. Glenair's Mini 147-100 Box is rated to IP64 which indicates total protection against dust, and from water sprayed from all directions.

### SP-R-0022A and ASTM-E-595 Vacuum Stability

Both specifications govern the "outgassing" of non-metallic materials for use in spacecraft. Tests measure Total Mass Loss which may not exceed 1.0% of the total specimen mass. Tests for this standard also measure Collected Volatile Condensable Materials from Outgassing in a Vacuum Environment; which means they measure odor and toxicity emitted from the material. All Glenair CostSaver Composite EMI/RFI Boxes are tested and approved to these standards.

### IEC 79-7 MOD (ISA-S12.16.01) Hazardous Area Explosion Protection

Electrical enclosures are certified for use in hazardous areas such as oil-rigs and tankers by standards organizations such as CENELEC. Tests measure the ability of an electrical apparatus to prevent the emission of sparks, arcs or hot surface temperatures from igniting a fire in a hazardous area. Glenair Composite EMI/RFI Boxes meet E EX e IIB T3 (increased safety) in Class I, Zones 1 and 2 hazardous locations.

### UL 94: Flammability of Plastic Materials

This requirement covers flammability of plastic materials used in devices and appliances. The flammability properties of materials are measured in response to heat and flame under controlled laboratory conditions. All Glenair CostSaver Composite EMI/RFI boxes are tested and approved to this standard.

### Bombardier Toxicity and Federal Railroad Administration Flame Spread, Smoke Density and Toxicity

This requirement covers material flammability and toxicity IAW with both aircraft and rail transportation requirements. Testing was completed on actual molded box samples, in the medium gray color, made from Ultem 2300-GY4001. Testing consisted of flammability IAW ASTM E 162, rate of smoke generation IAW ASTM E 662 and Bombardier SMP 800-C toxic gas generation. The Glenair composite box samples passed all tests. For additional information please request test report No. 08-002-923(B) for Bombardier toxicity, and test report No. 08-002-923(A) for surface flammability and rate of smoke generation.

## Corrosion resistance and weight reduction are just part of the story for these Glenair junction box application examples

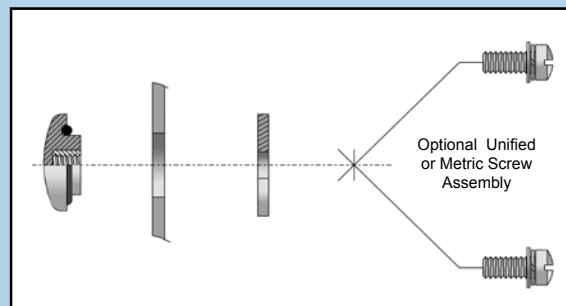
### Future Soldier:

Weight reduction was the principal goal in selecting the Glenair composite box for the JEDI Warrior Program. The boxes house Lithium battery packs used to power video image and battlefield data collection systems carried by the soldier. The interconnect system and its power supply must be able to withstand the rigors of exposure to mud, dust and abusive handling. The complete solution from Glenair also included our Series 800 "Mighty Mouse" Connector and overmolded cable sets.

### Ministry of Defense:

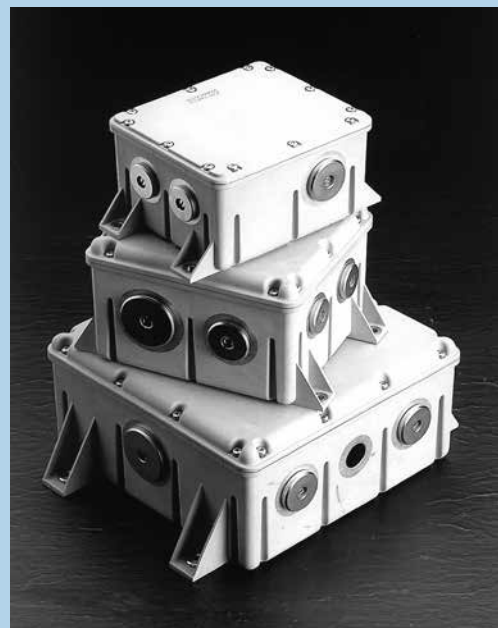
Glenair composite boxes for the UK Ministry of Defense were subjected to a rigorous testing program, including high-duration shock, EMI and salt-spray corrosion resistance. The MOD has chosen the Glenair boxes as standard replacements for existing aluminium junction boxes which became too expensive to maintain due to high-impact breakage and corrosion. The Glenair boxes now serve in submarines, missile-frigates and other shipboard applications.

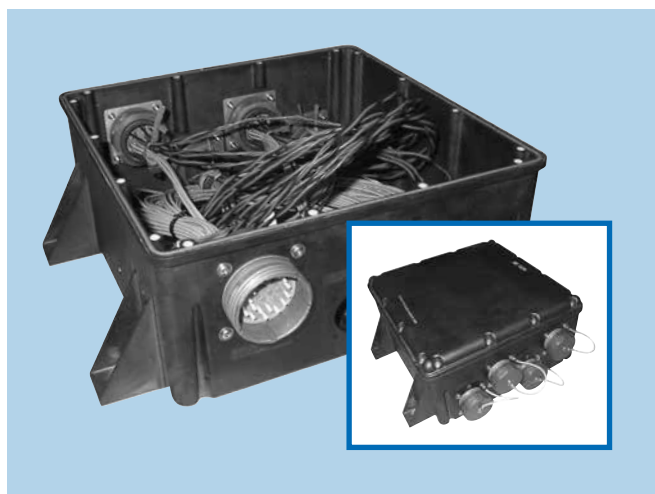
## Step Eight: Select Additional Penetrations for Hole-Cap Assemblies



Junction boxes may be equipped with additional penetrations for future expansion needs, or for applications where one box design will be used in several different configurations. Glenair supplies a hole-cap assembly to seal unused penetrations against the environment. The hole-cap assemblies are rated to IP67 for particle and moisture protection.

Glenair can produce virtually any design of custom cap or lid required. Please consult the factory.





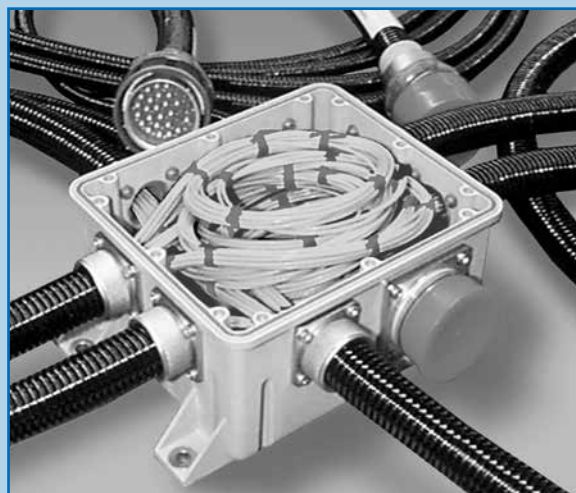
**Missile-Control:**

The ability to withstand extremes in shock and vibration, as well as long term corrosion protection and electromagnetic compatibility were baseline requirements for this missile control junction box. The complete system includes fiber optic connectors, termini and cabling. Interconnect systems of this type must be able to sit idle for many years, and then perform flawlessly in the blink of an eye.

**Fiber-Optic Storage:**

In this application, Glenair was able to provide a complete, turnkey interconnect assembly which included both the lightweight composite box, as well as the conduit and the fiber optic interconnects. The box doubles as an environmentally controlled storage area for additional lengths of fiber-optic cable. In the event a termination is damaged, both the conduit and box may be opened to access the termini and the wire-loops for easy repair.

Every Picture  
Tells a Story



This One  
Speaks Volumes

Glenair is in the business of solving even the most complex interconnect design problems. We know that your problem isn't solved when the connector and cable are selected. The real work starts with the packaging of the key components for actual use. Glenair is ready with junction box solutions that incorporate our complete line of interconnect products—all available in corrosion-free composite thermoplastic. At Glenair, we're ready with both the individual interconnect technologies, as well as the most innovative and effective packaging solutions available today. Now *that's* a story worth telling.

E

**Glenair Standard US Navy Composite Boxes**

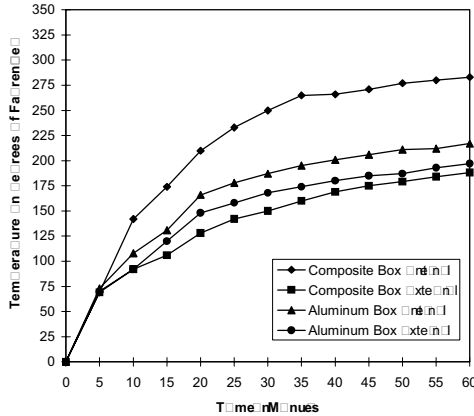
<u>Stock Code</u>	<u>Description</u>
CDNWC 655-03-001 (NAVSEA umbrella stock code for the Glenair Electrical Junction Box Series).	Junction Box, with or without terminal blocks, four sizes
	Electrical Box, 115V, 15 Amp, two sizes, single and dual receptacle
	Sound Powered Telephone Box with Glenair composite jack receptacle, three sizes, single, dual and quad

# Glenair CostSaver Composite EMI/RFI Junction Boxes Electrical Performance Specifications

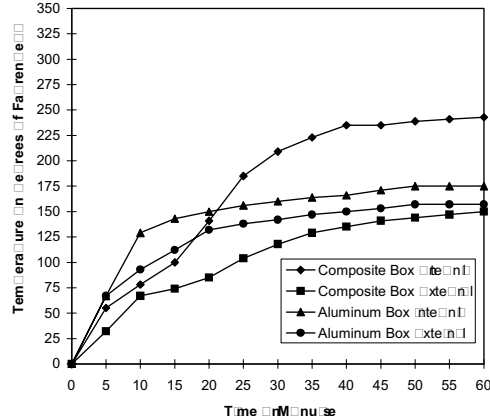


Composite  
Junction  
Boxes

Thermal Conductivity at 60,000 Feet Elevation

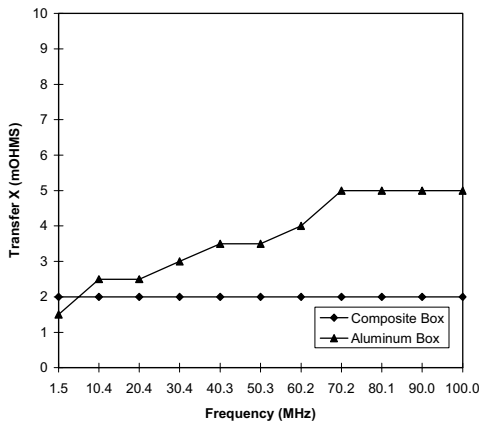


Thermal Conductivity at Sea Level

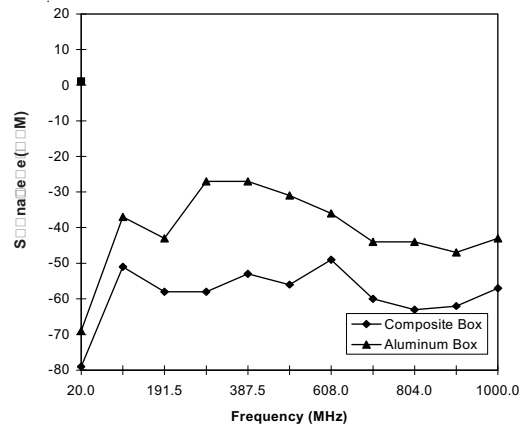


Consult factory for thermally conductive material option 10-20 w/mk

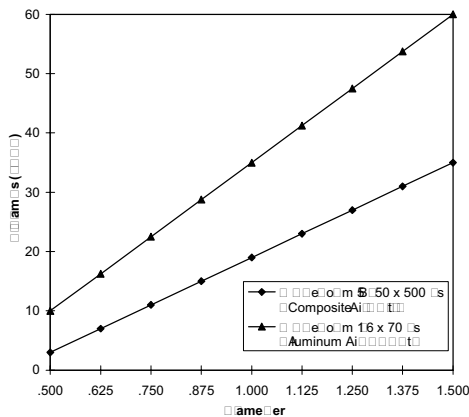
Transfer Impedance



Radiated Emissions



Indirect Lightning Strike Threshold  
SAE - AE4L-87-3, Wave Forms 1 & 5B



The values shown for indirect lightning strike represent the approximate threshold of conductive composite tubular attachment components having diameters equal to those listed. For example, connector shell size is calculated in .0625 increments; shell size 10 = 10 x .0625 or .625 diameter. Cable entry diameter is another consideration. Use the smallest part diameter when evaluating thresholds. Consult factory for additional information.



### Box Specification Worksheet

Glenair brings a unique strength to junction box systems: the ability to build a turnkey assembly—wired, terminated, tested and complete with all the necessary fittings and accessories. We are the only nonmetallic enclosure manufacturer in the world which can supply an integrated interconnect system of this type. And we are pleased to provide this service at small quantity and prototype levels. This worksheet summarizes the major decision points in the design and development of an interconnect box assembly.

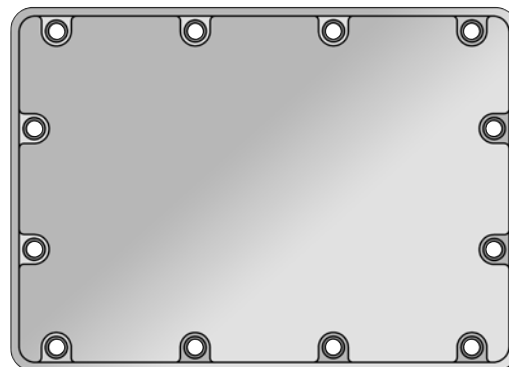
<p><b>Originator Contact Information</b></p> <p>Name: _____</p> <p>Location: _____</p> <p>Phone: _____</p> <p>Fax: _____</p> <p>E-Mail: _____</p> <p><b>Select Box Series Size and Type</b></p> <p><input type="checkbox"/> Ultra-Miniature Box (140-074)</p> <p><input type="checkbox"/> Mini Junction Box (140-100)</p> <p><input type="checkbox"/> Small Junction Box (140-101)</p> <p><input type="checkbox"/> Medium Junction Box (140-102)</p> <p><input type="checkbox"/> Large Junction Box (140-103)</p> <p><input type="checkbox"/> Jumbo Junction Box (140-107)</p> <p><input type="checkbox"/> Small Low-Profile Box (140-104)</p> <p><input type="checkbox"/> Med Low-Profile Box (140-105)</p> <p><input type="checkbox"/> Small Three-Legged Box (140-106)</p> <p><input type="checkbox"/> Octagonal Box (140-200)</p> <p><input type="checkbox"/> Twelve Port Box (140-203)</p> <p><b>Select Box Color</b></p> <p><input type="checkbox"/> Black</p> <p><input type="checkbox"/> Grey</p> <p><input type="checkbox"/> Brown</p>	<p><input type="checkbox"/> Purple</p> <p><input type="checkbox"/> Other _____</p> <p><b>Select Plating Type</b></p> <p><input type="checkbox"/> Electroless Nickel/Metallic Finish</p> <p><input type="checkbox"/> Zinc Nickel/Matte black Finish</p> <p><input type="checkbox"/> Ni-PTFE <i>1000 Hour Gray™</i></p> <p><input type="checkbox"/> No Plating</p> <p><b>Select Plating Coverage</b></p> <p><input type="checkbox"/> Internal Plating with Selectively Plated Entry Holes</p> <p><input type="checkbox"/> External Plating Only</p> <p><input type="checkbox"/> No Plating (non-conductive)</p> <p><b>Select Grounding Device</b></p> <p><input type="checkbox"/> Integrated Grounding Foot</p> <p><input type="checkbox"/> Side-Mounted Grounding Stud</p> <p><input type="checkbox"/> None</p> <p><b>Select Internal Mounting Plate</b></p> <p><input type="checkbox"/> Yes</p> <p><input type="checkbox"/> No</p>	<p><b>Specify Internal Terminal Rail Mounting Plate Drilling</b></p> <p><input type="checkbox"/> Not Applicable</p> <p><input type="checkbox"/> Standard Drilling Per Catalog</p> <p><input type="checkbox"/> Per Customer Drawing</p> <p><b>Wire/Cable Construction</b></p> <p><input type="checkbox"/> Standard Armored/Shielded Cable</p> <p><input type="checkbox"/> Glenair Overmolded Cable</p> <p><input type="checkbox"/> Plastic Convuluted Tubing</p> <p><input type="checkbox"/> Metal-Core Conduit</p> <p><input type="checkbox"/> Not Applicable</p> <p><b>Supply Additional Penetrations with Hole Cap Assemblies?</b></p> <p><input type="checkbox"/> Yes</p> <p><input type="checkbox"/> No</p> <p><input type="checkbox"/> Not Applicable</p> <p><b>Glenair to Provide Turnkey Assembly of Box Components?</b></p> <p><input type="checkbox"/> Yes. (Bill of Materials and/or Drawing Required)</p> <p><input type="checkbox"/> No</p> <p><input type="checkbox"/> Not Applicable</p>
---	--	--

#### Select/Indicate Connector and Fitting Locations:

Indicate the locations of your selected connectors and fittings. You may simply describe the devices in the space provided ("Two jam-nut 15 pin D38999 Series III Connectors go on Side "A") or you may sketch the fittings and connectors in place with appropriate labels. There are no limits to the size and number of penetrations other than the physical boundaries of the box surfaces. Use the dimensional information published with each connector or feed-through series, or call our factory for assistance.

**NOTE: Box Series Numbers are for reference only. Call the factory for part number assignment for custom box configurations.**

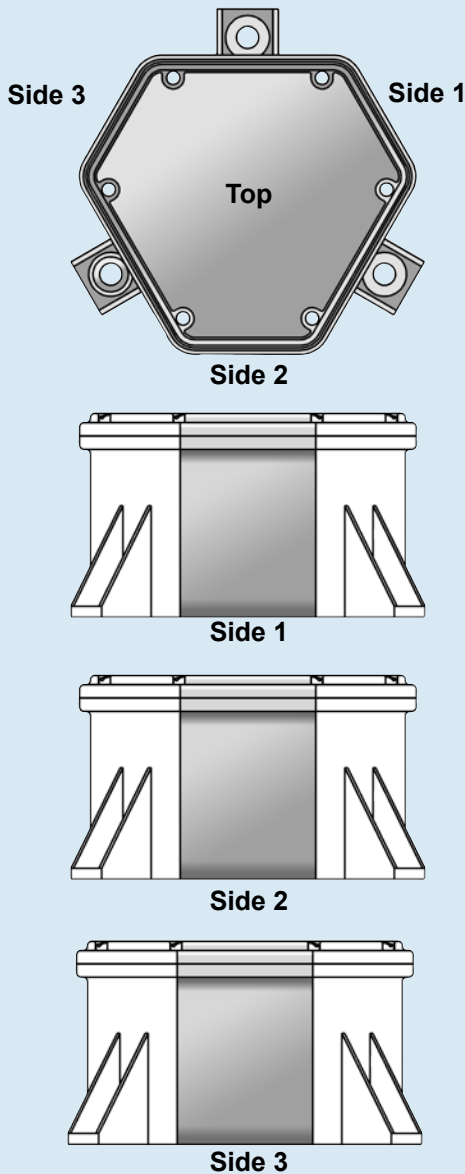
#### Rectangular Box Top Template



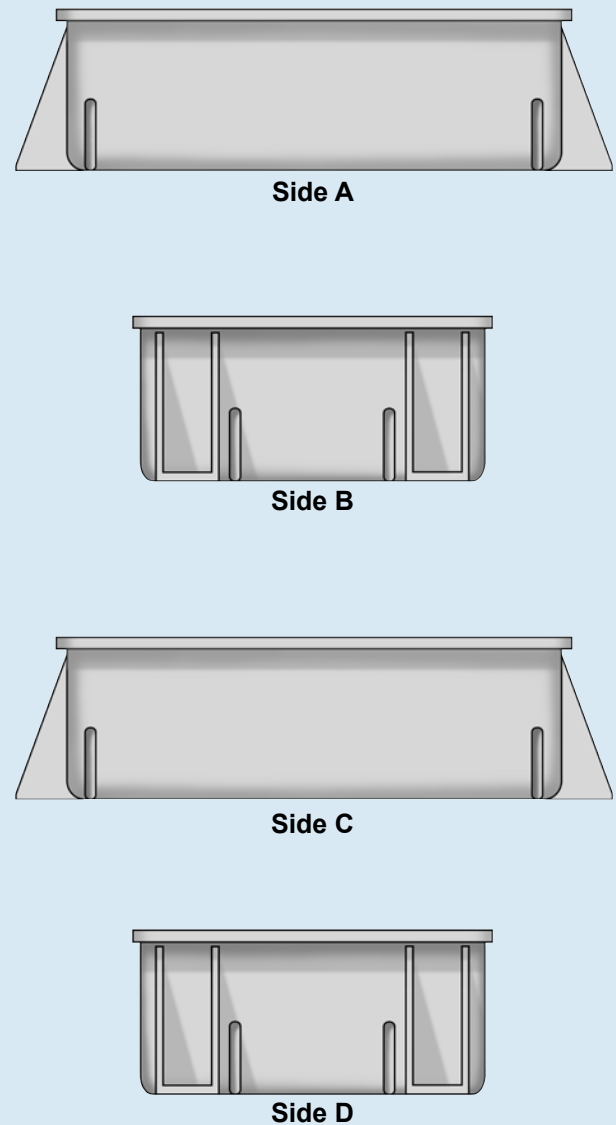
## Input-Output Device Position Template

This template may be used to indicate initial positioning of connectors, feed-throughs and fittings such as ground lugs. Indicate the location of all special markings or labels including correct wording/numbering.

### Three-Legged Junction Boxes

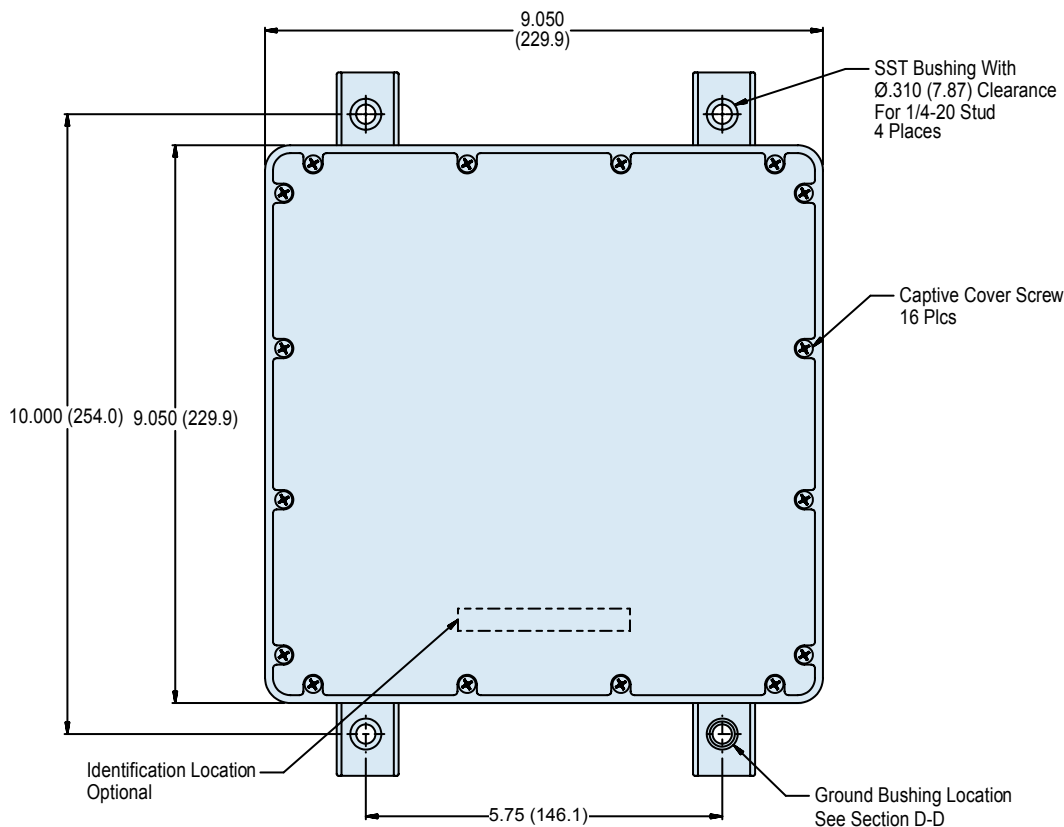
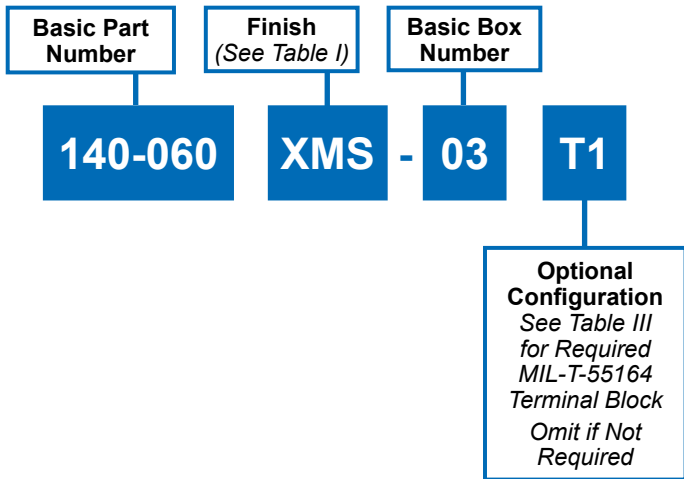


### Rectangular Junction Boxes



The structural ribs located on the rectangular box sides are provided to increase the overall strength of the box. The ribs may be removed to accommodate additional fittings if necessary. For additional assistance in locating connectors and fittings please consult the factory. For custom fittings, such as specially designed doors or lid covers, please consult the factory. Application engineering for customer specified box assemblies is provided free upon request.

**140-060XMS-03**  
**(NSN: 5975-01-557-2679)**  
**Grounded Composite Junction Box**  
**15 Ft. Submersion**



**FIGURE 1 TOP VIEW**

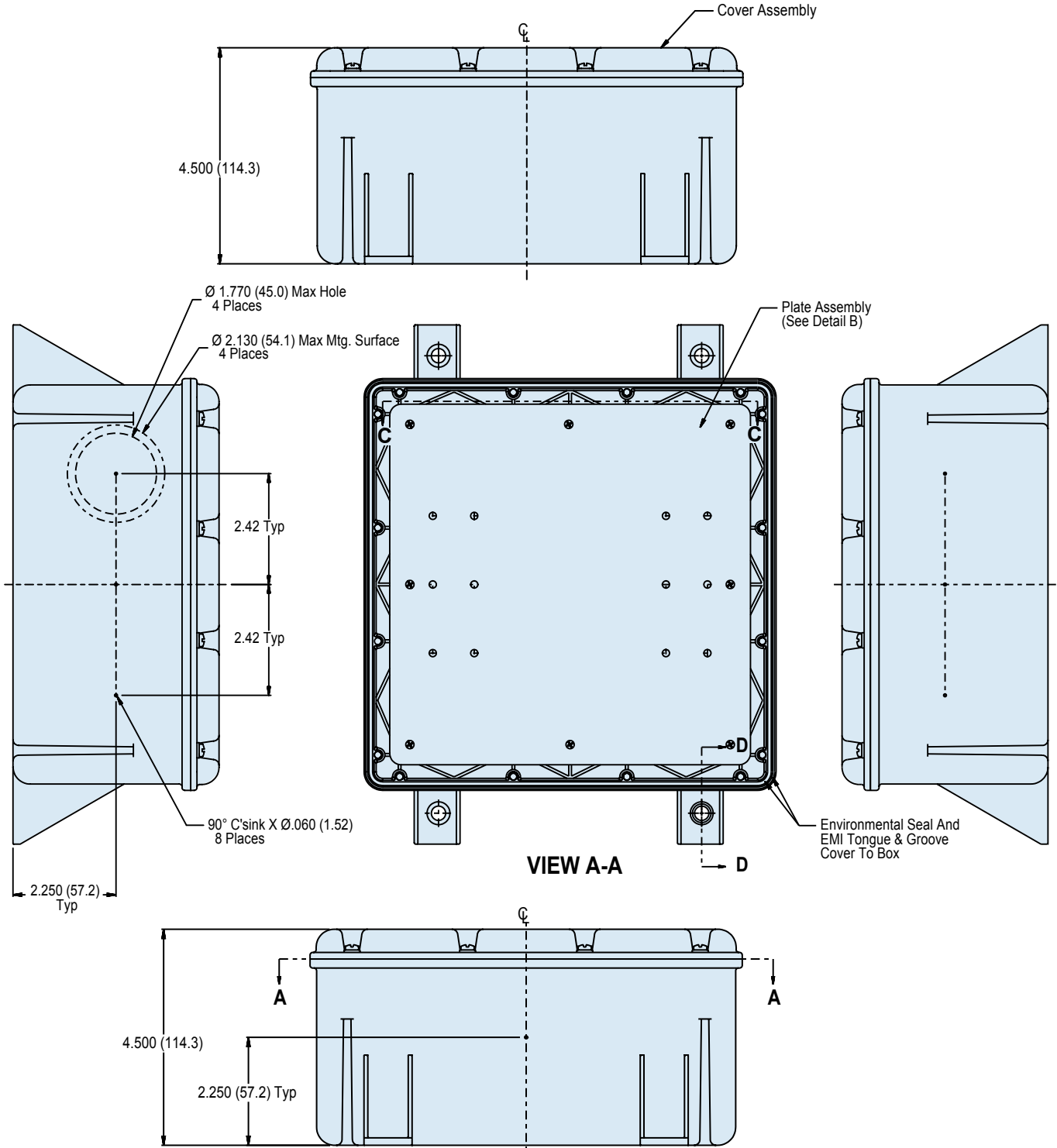
**E**



**140-060XMS-03**  
**(NSN: 5975-01-557-2679)**  
**Grounded Composite Junction Box**  
**15 Ft. Submersion**

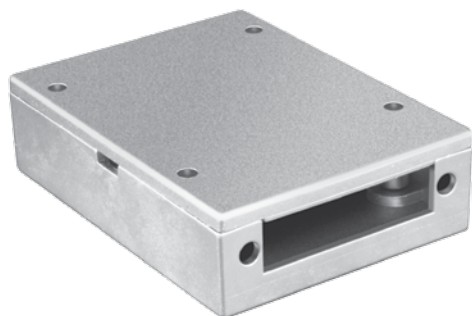


Composite  
Junction  
Boxes

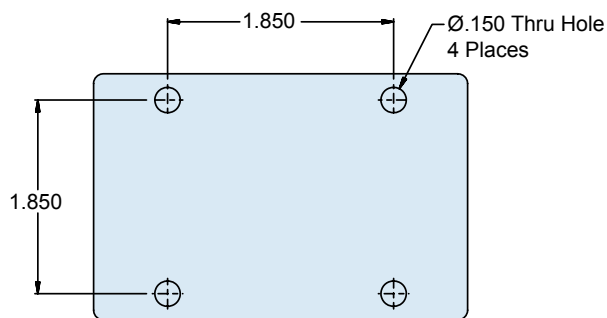
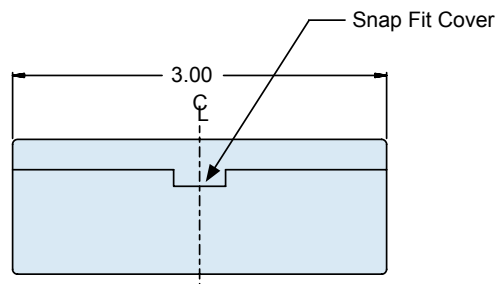
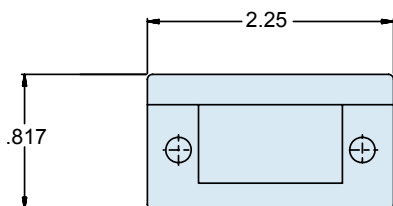
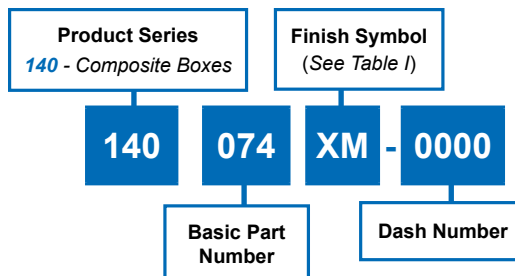


**FIGURE 2**

**E**



**Ultra-Miniature  
Series 140-074  
CostSaver Composite  
Junction Box**



**TABLE I**

Symbol	Finish Description
XM	Electroless Nickel
XO	No Plating (Non-Conductive Finish)
XMT	2000 Hour Corrosion Resistant Ni-PTFE, Nickel-Fluorocarbon Polymer. 1000 Hour Grey™
XMC	Electroless Nickel per Lockheed Martin Specification FPS-3084

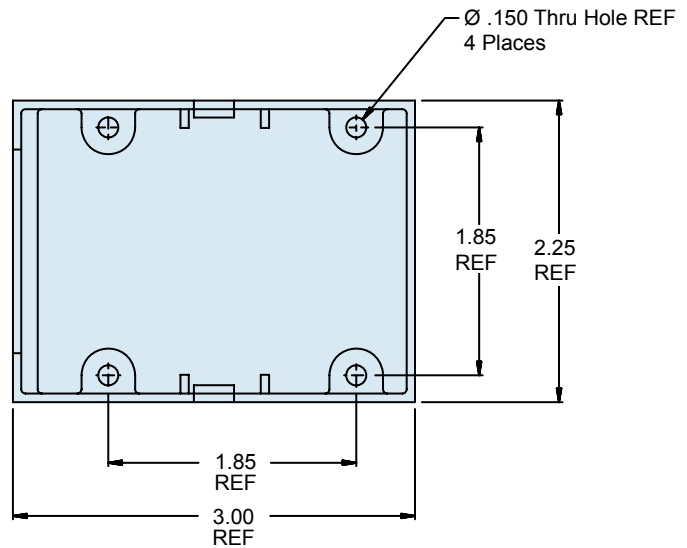
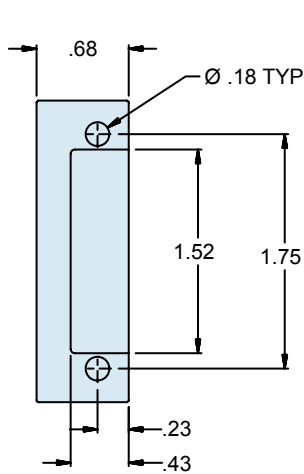
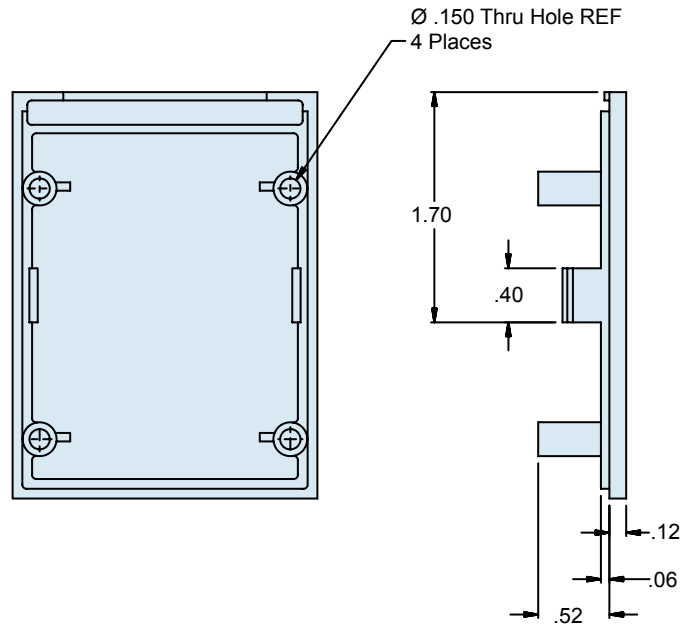
**NOTES**

1. Use dash number 0000 for basic box with no additional options beyond your specified finish.
2. Box accommodates 1" MTC connector.
3. Metric dimensions (mm) are indicated in parentheses and are for reference only.

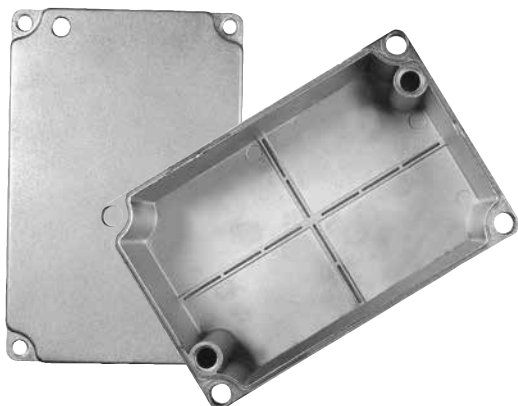
Series 140-074  
Ultra-Miniature Junction Box  
Product Facts and Dimensional Details



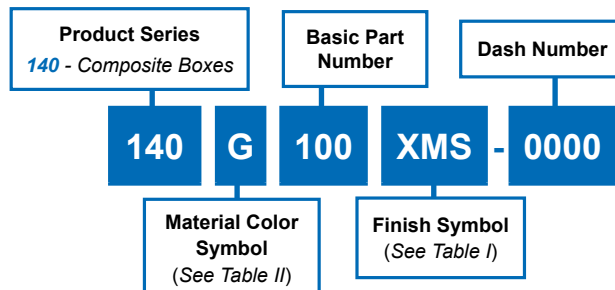
Composite  
Junction  
Boxes



E



### Mini Series 140-100 CostSaver Composite Junction Box



**TABLE II: MATERIAL COLOR & FINISH OPTIONS**

Sym	Material & Color	Finish Options
B	Thermoplastic / Black	XO and XMS
G	Thermoplastic / Grey	XO and XMS
-	Thermoplastic / NA	XM, XW and XZN

TABLE I: FINISHES	
Symbol	Finish Description
XO	No Plating (Non-Conductive Finish)
XMS	Internal Surfaces - Electroless Nickel External Surfaces - See Table II
XM	All Surfaces – Electroless Nickel
XW	All Surfaces – Cadmium Olive Drab over Electroless Nickel
XZN	All Surfaces – Zinc Nickel/Black
XMT	2000 Hour Corrosion Resistant Ni-PTFE, Nickel-Fluorocarbon Polymer. 1000 Hour Grey™

**TABLE III: KEY DIMENSIONS**

Box Series Number	External	Internal
140-100 Mini	2.55 (64.8) x 3.85 (97.8) x 1.38 (35.1)	2.08 (52.8) x 3.38 (85.9) x 1.06 (26.9)

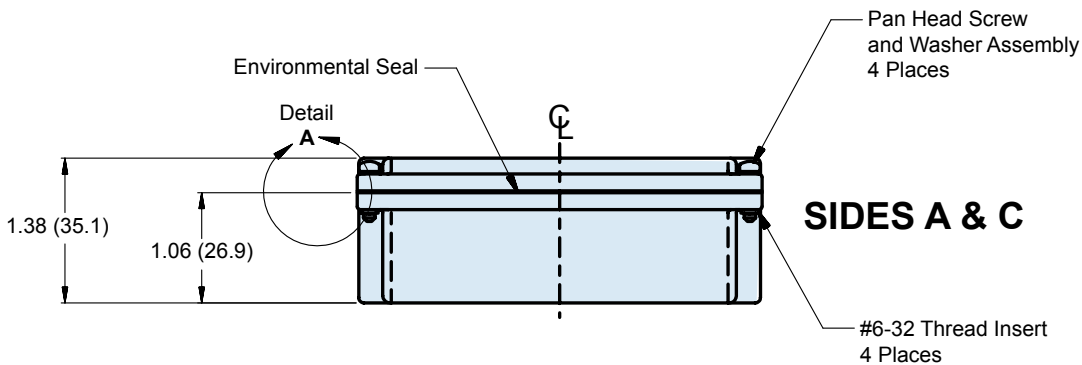
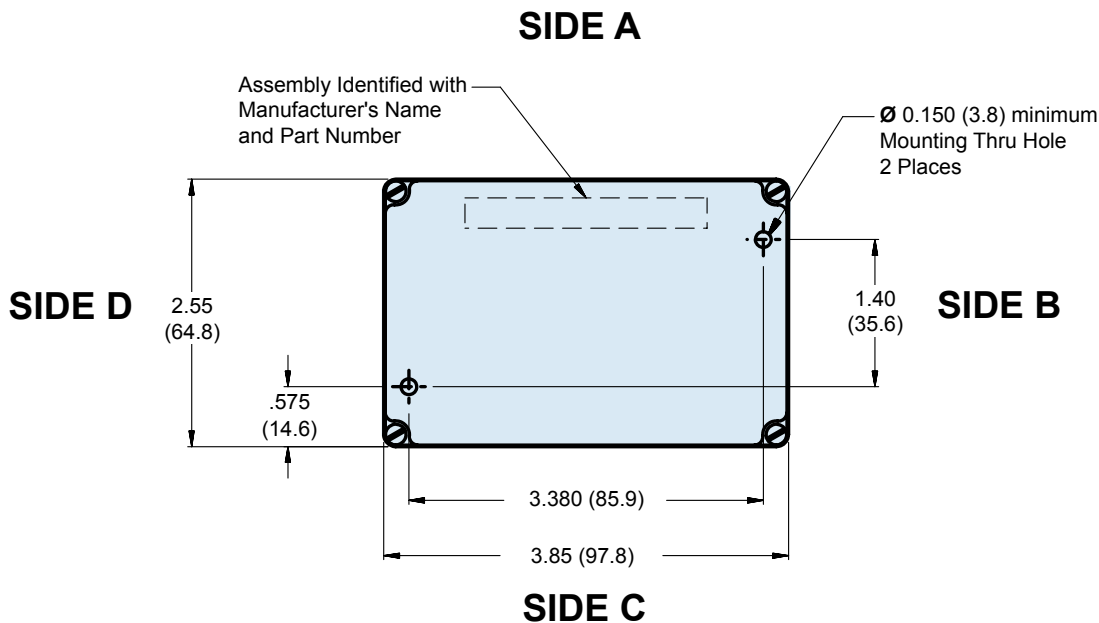
#### NOTES

1. Use Dash Number 0000 for Basic Box with No Additional Options Beyond Your Specified Finish. 0000 Basic Box Includes #6-32 UNC Fasteners.
2. Box Series Numbers are for reference only. Please complete the worksheet on E-14 and call the factory for part number assignment for your specific box configuration.
3. Metric dimensions (mm) are in parenthesis and for reference only

Series 140-100  
Mini Junction Box

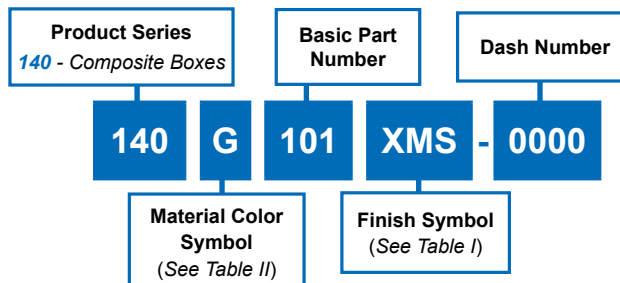


Composite  
Junction  
Boxes



**SIDES B & D**

**E**



**Small  
Series 140-101  
CostSaver Composite  
Junction Box**

**TABLE II: MATERIAL COLOR & FINISH OPTIONS**

Sym	Material & Color	Finish Options
B	Thermoplastic / Black	XO and XMS
G	Thermoplastic / Grey	XO and XMS
-	Thermoplastic / NA	XM, XW and XZN

**TABLE I: FINISHES**

Symbol	Finish Description
XO	No Plating (Non-Conductive Finish)
XMS	Internal Surfaces - Electroless Nickel External Surfaces - See Table II
XM	All Surfaces - Electroless Nickel
XW	All Surfaces - Cadmium Olive Drab over Electroless Nickel
XZN	All Surfaces - Zinc Nickel/Black
XMT	2000 Hour Corrosion Resistant Ni-PTFE, Nickel-Fluorocarbon Polymer. <i>1000 Hour Grey™</i>

**TABLE III: KEY DIMENSIONS**

Box Series Number	External Dimensions	Internal Dimensions (with Aluminum Mounting Plate Installed, if applicable)
Small 140-101	5.18 (132) x 6.00 (152) x 3.35 (85)	3.94 (100) x 4.72 (120) x 2.63 (67)

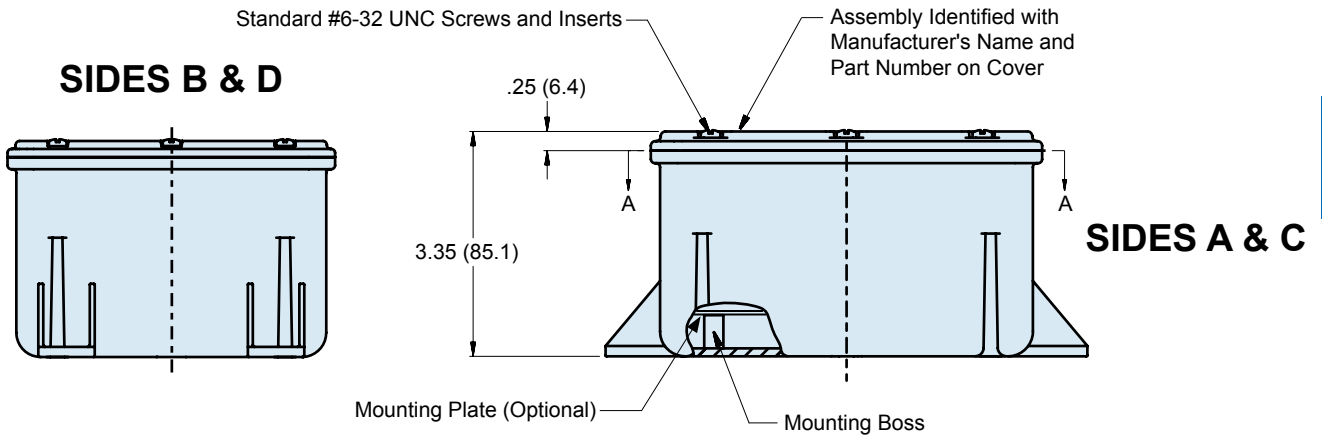
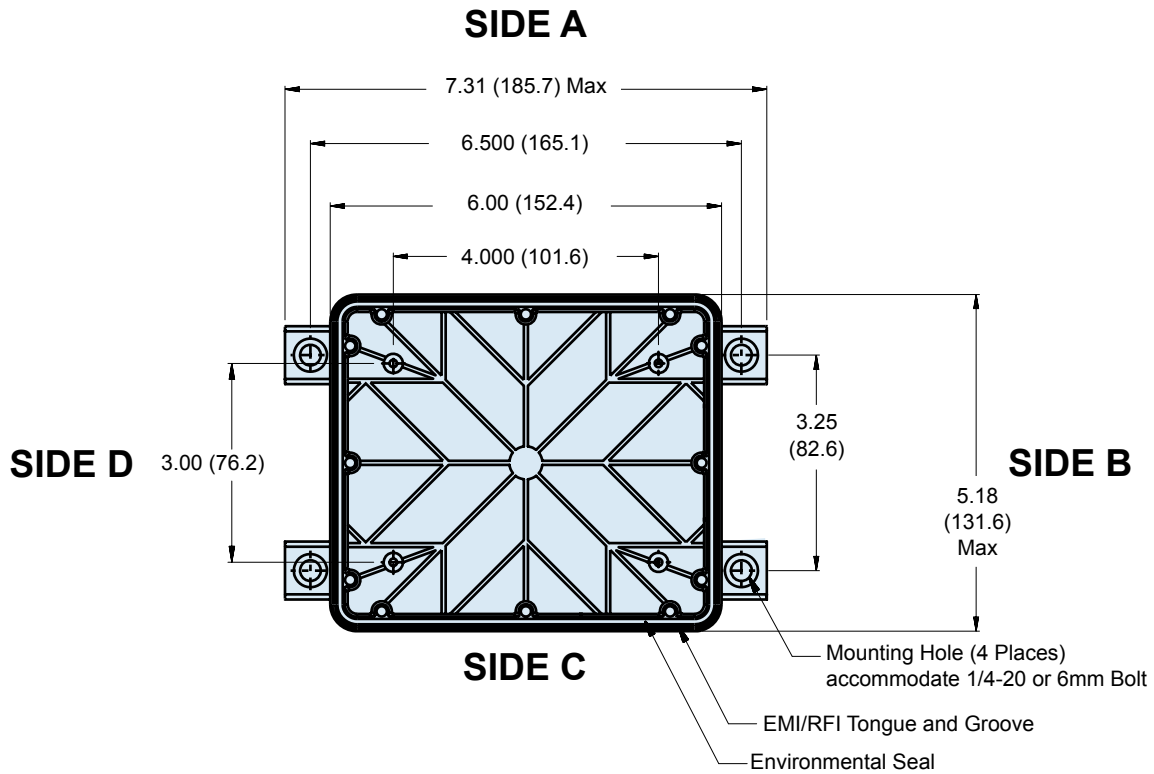
**NOTES**

1. Use Dash Number 0000 for Basic Box with No Additional Options Beyond Your Specified Finish. 0000 Basic Box Includes #6-32 UNC Fasteners.
2. Box Series Numbers are for reference only. Please complete the worksheet on E-14 and call the factory for part number assignment for your specific box configuration.
3. Metric dimensions (mm) are in parenthesis and for reference only

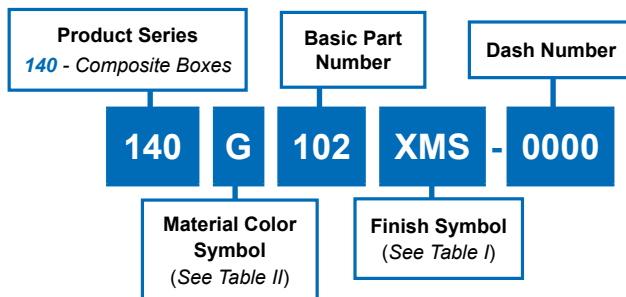
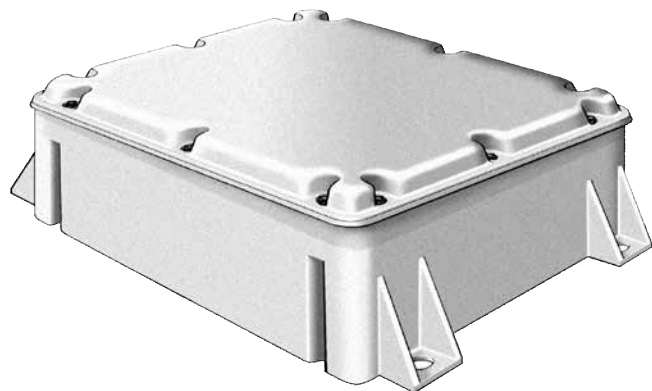
Series 140-101  
Small Junction Box



Composite  
Junction  
Boxes



**E**



**Medium  
Series 140-102  
CostSaver Composite  
Junction Box**

**TABLE II: MATERIAL COLOR & FINISH OPTIONS**

Sym	Material & Color	Finish Options
B	Thermoplastic / Black	XO and XMS
G	Thermoplastic / Grey	XO and XMS
-	Thermoplastic / NA	XM, XW and XZN

**TABLE I: FINISHES**

Symbol	Finish Description
XO	No Plating (Non-Conductive Finish)
XMS	Internal Surfaces - Electroless Nickel External Surfaces - See Table II
XM	All Surfaces - Electroless Nickel
XW	All Surfaces - Cadmium Olive Drab over Electroless Nickel
XZN	All Surfaces - Zinc Nickel/Black
XMT	2000 Hour Corrosion Resistant Ni-PTFE, Nickel-Fluorocarbon Polymer. 1000 Hour Grey™

**TABLE III: KEY DIMENSIONS**

Box Series Number	External Dimensions	Internal Dimensions (with Aluminum Mounting Plate Installed, if applicable)
Medium 140-102	5.95 (151) x 6.82 (173) x 4.26 (108)	4.73 (120) x 5.91 (150) x 3.54 (90)

**NOTES**

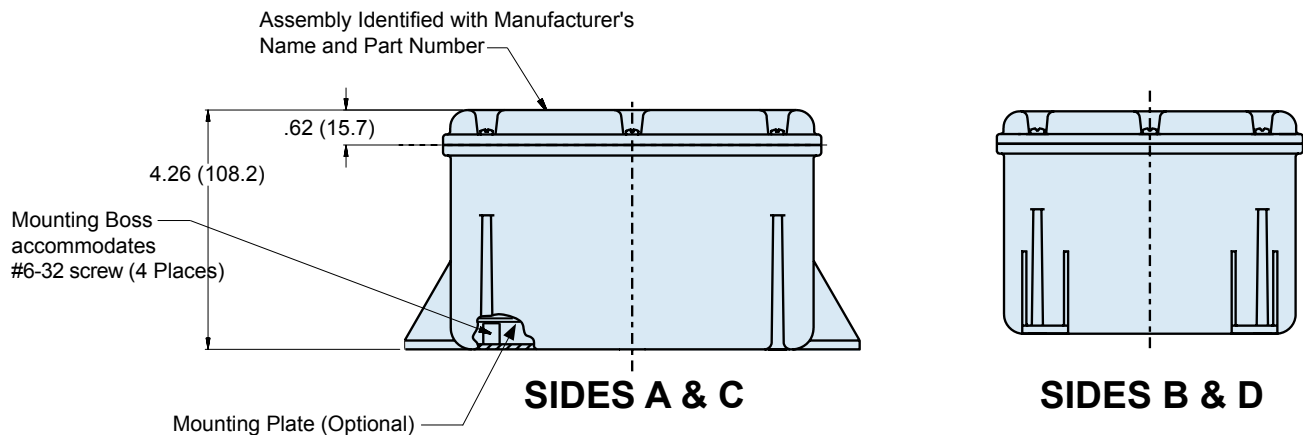
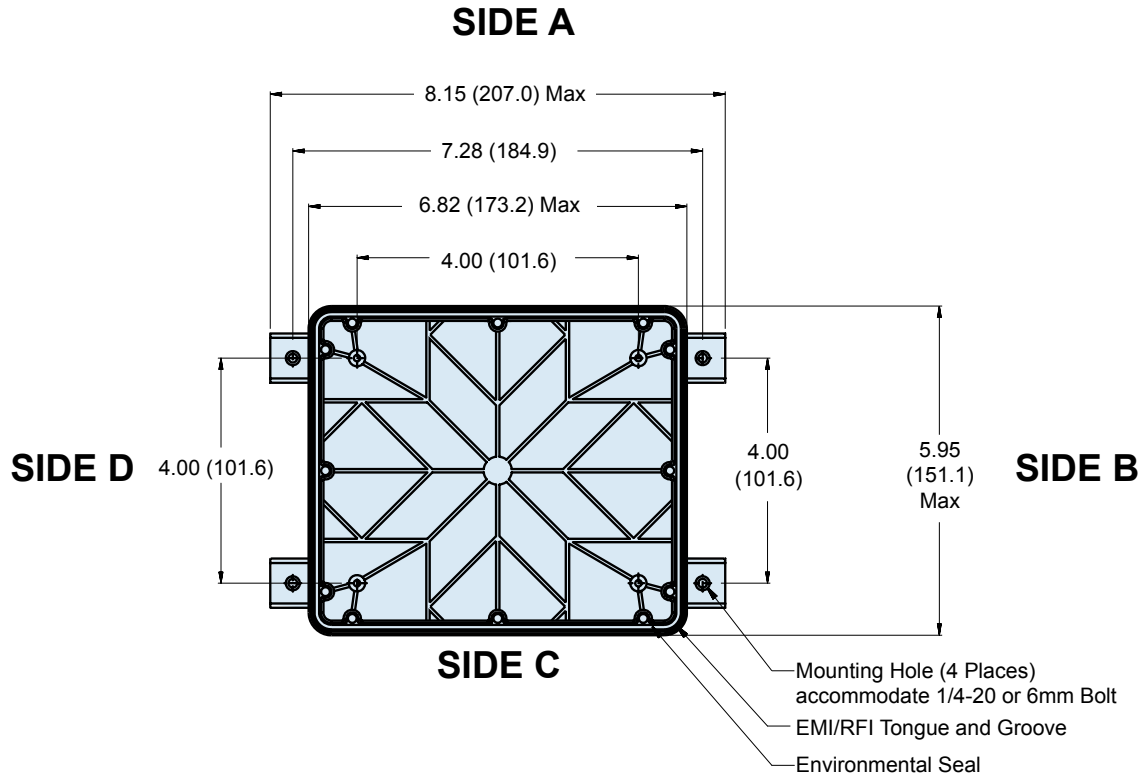
1. Use Dash Number 0000 for Basic Box with No Additional Options Beyond Your Specified Finish. 0000 Basic Box Includes #6-32 UNC Fasteners.
2. Box Series Numbers are for reference only. Please complete the worksheet on E-14 and call the factory for part number assignment for your specific box configuration.
3. Metric dimensions (mm) are in parenthesis and for reference only

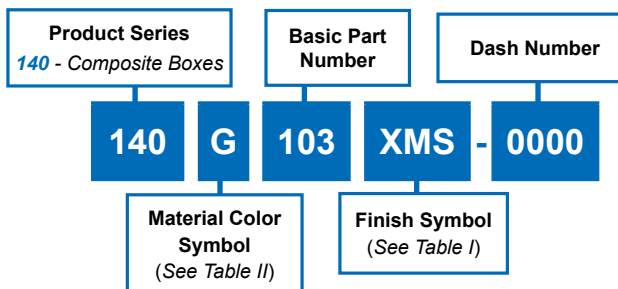


Series 140-102  
Medium Junction Box



Composite  
Junction  
Boxes





**Large**  
**Series 140-103**  
**CostSaver Composite**  
**Junction Box**

**TABLE II: MATERIAL COLOR & FINISH OPTIONS**

Sym	Material & Color	Finish Options
B	Thermoplastic / Black	XO and XMS
G	Thermoplastic / Grey	XO and XMS
-	Thermoplastic / NA	XM, XW and XZN

**TABLE I: FINISHES**

Symbol	Finish Description
XO	No Plating (Non-Conductive Finish)
XMS	Internal Surfaces - Electroless Nickel External Surfaces - See Table II
XM	All Surfaces - Electroless Nickel
XW	All Surfaces - Cadmium Olive Drab over Electroless Nickel
XZN	All Surfaces - Zinc Nickel/Black
XMT	2000 Hour Corrosion Resistant Ni-PTFE, Nickel-Fluorocarbon Polymer. 1000 Hour Grey™

**TABLE III: KEY DIMENSIONS**

Box Series Number	External Dimensions	Internal Dimensions (with Aluminum Mounting Plate Installed, if applicable)
<b>Large 140-103</b>	9.10 (231) x 9.10 (231) x 4.50 (114)	7.87 (200) x 7.87 (200) x 3.78 (96)

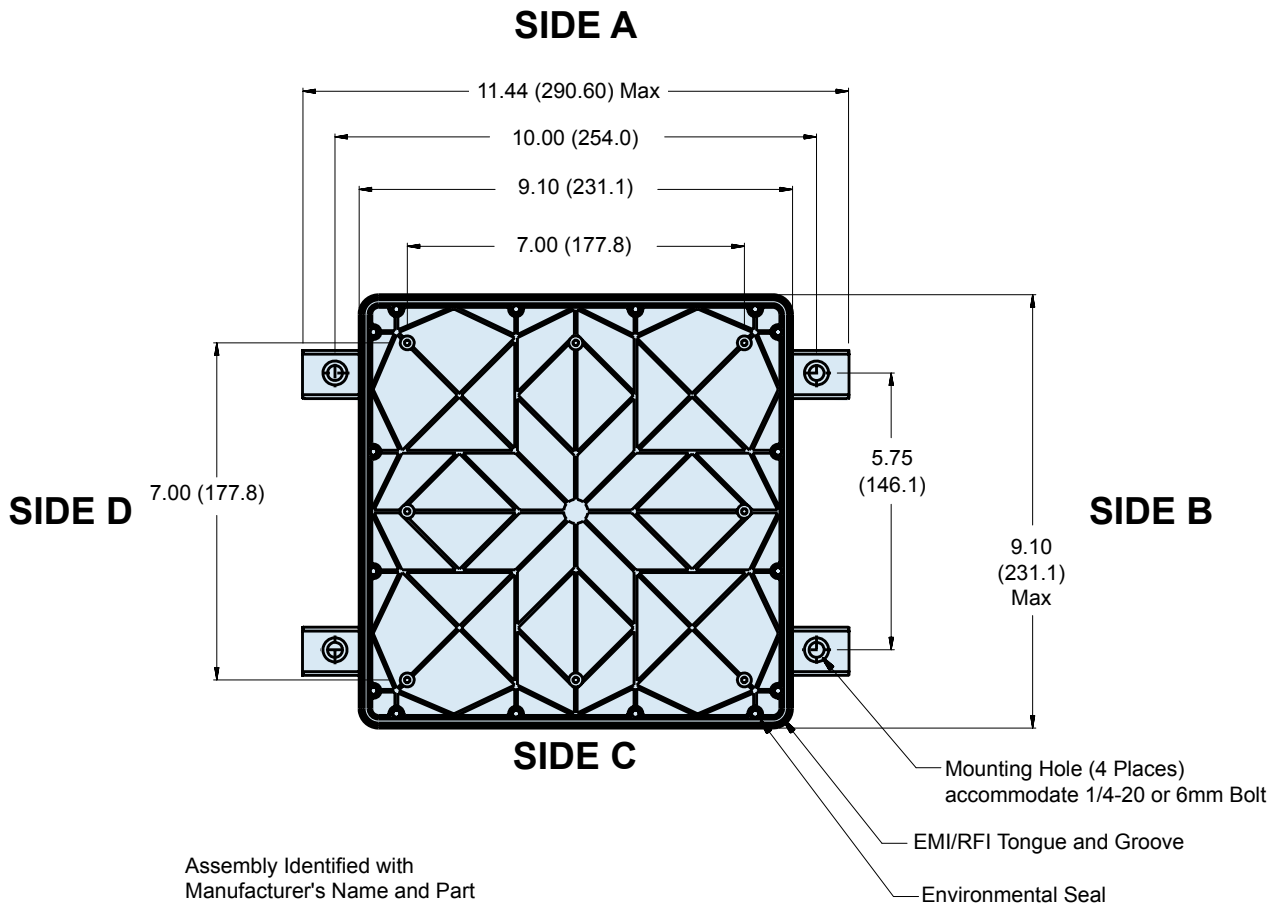
**NOTES**

- Use Dash Number 0000 for Basic Box with No Additional Options Beyond Your Specified Finish. 0000 Basic Box Includes #6-32 UNC Fasteners.
- Box Series Numbers are for reference only. Please complete the worksheet on E-14 and call the factory for part number assignment for your specific box configuration.
- Metric dimensions (mm) are in parenthesis and for reference only

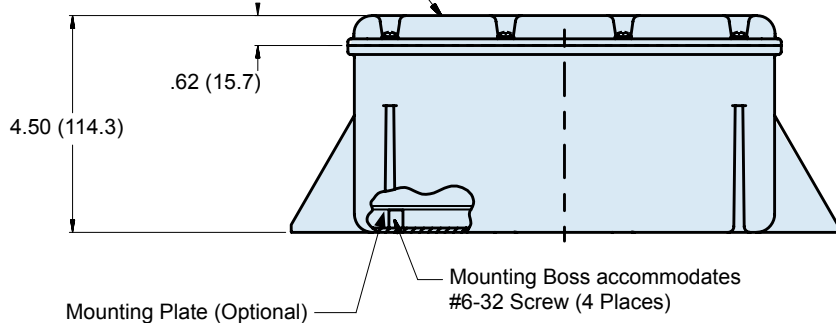
Series 140-103  
Large Junction Box



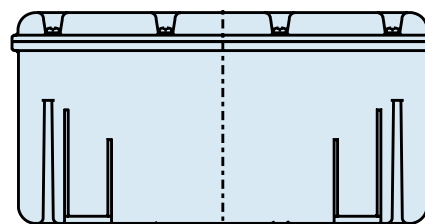
Composite  
Junction  
Boxes



Assembly Identified with  
Manufacturer's Name and Part  
Number



**SIDES A & C**



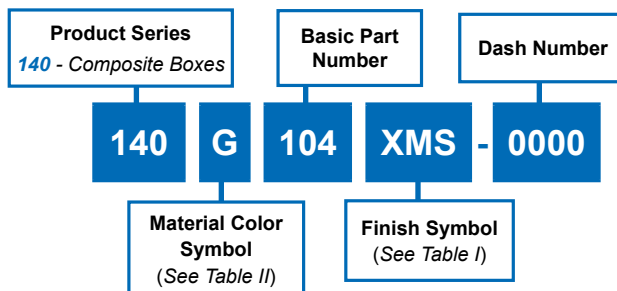
**SIDES B & D**

**E**

## Series 140-104 Small Low-Profile Box



### Small Low-Profile Series 140-104 CostSaver Composite Junction Box



**TABLE II: MATERIAL COLOR & FINISH OPTIONS**

Sym	Material & Color	Finish Options
B	Thermoplastic / Black	XO and XMS
G	Thermoplastic / Grey	XO and XMS
-	Thermoplastic / NA	XM, XW and XZN

**TABLE I: FINISHES**

Symbol	Finish Description
XO	No Plating (Non-Conductive Finish)
XMS	Internal Surfaces - Electroless Nickel External Surfaces - See Table II
XM	All Surfaces - Electroless Nickel
XW	All Surfaces - Cadmium Olive Drab over Electroless Nickel
XZN	All Surfaces - Zinc Nickel/Black
XMT	2000 Hour Corrosion Resistant Ni-PTFE, Nickel-Fluorocarbon Polymer. 1000 Hour Grey™

**TABLE III: KEY DIMENSIONS**

Box Series Number	External Dimensions	Internal Dimensions (with Aluminum Mounting Plate Installed, if applicable)
Low-Profile 140-104	5.86 (149) x 5.86 (149) x 2.13 (54)	4.90 (124) x 4.90 (124) x 1.53 (39)

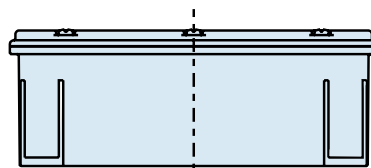
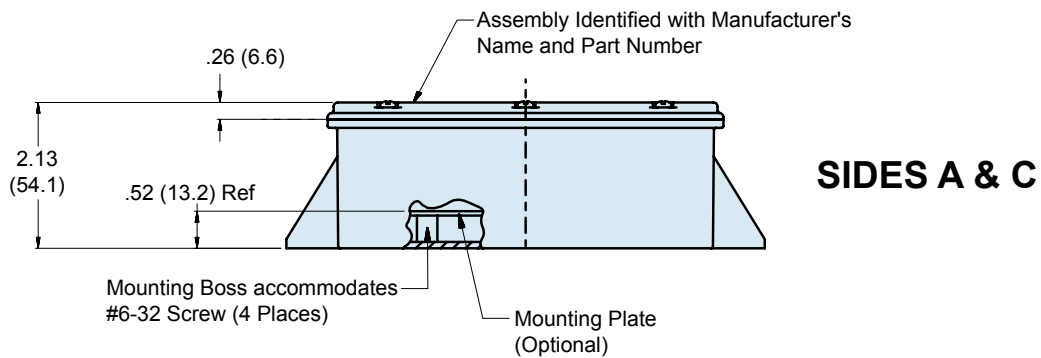
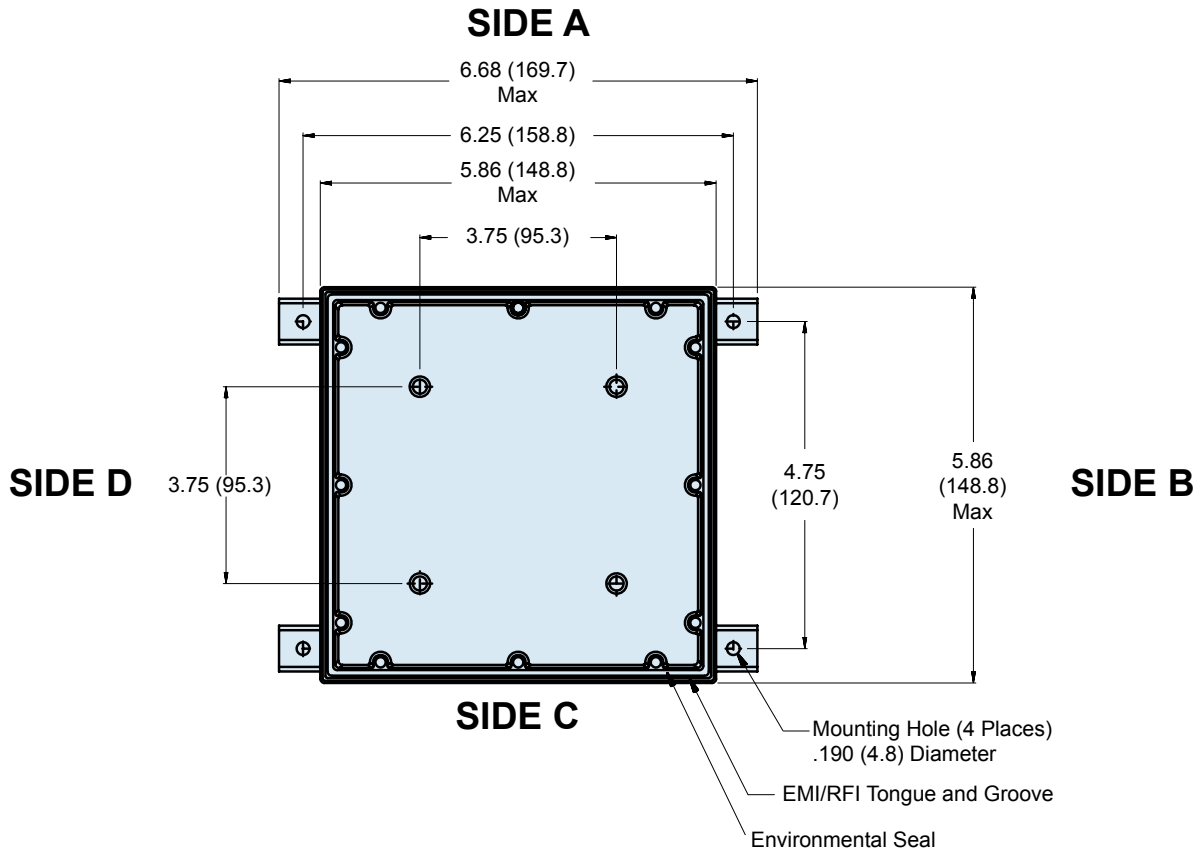
#### NOTES

- Use Dash Number 0000 for Basic Box with No Additional Options Beyond Your Specified Finish. 0000 Basic Box Includes #6-32 UNC Fasteners.
- Box Series Numbers are for reference only. Please complete the worksheet on E-14 and call the factory for part number assignment for your specific box configuration.
- Metric dimensions (mm) are in parenthesis and for reference only

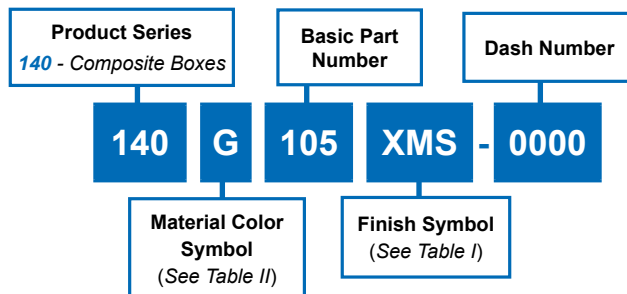
Series 140-104  
Small Low-Profile Box



Composite  
Junction  
Boxes



**E**



**Medium Low-Profile  
Series 140-105  
CostSaver Composite  
Junction Box**

**TABLE II: MATERIAL COLOR & FINISH OPTIONS**

Sym	Material & Color	Finish Options
B	Thermoplastic / Black	XO and XMS
G	Thermoplastic / Grey	XO and XMS
-	Thermoplastic / NA	XM, XW and XZN

**TABLE I: FINISHES**

Symbol	Finish Description
XO	No Plating (Non-Conductive Finish)
XMS	Internal Surfaces - Electroless Nickel External Surfaces - See Table II
XM	All Surfaces - Electroless Nickel
XW	All Surfaces - Cadmium Olive Drab over Electroless Nickel
XZN	All Surfaces - Zinc Nickel/Black
XMT	2000 Hour Corrosion Resistant Ni-PTFE, Nickel-Fluorocarbon Polymer. 1000 Hour Grey™

**TABLE III: KEY DIMENSIONS**

Box Series Number	External Dimensions	Internal Dimensions (with Aluminum Mounting Plate Installed, if applicable)
Medium Low-Profile 140-105	6.93 (176) x 5.85 (149) x 2.44 (62.0)	4.92 (125) x 6.02 (153) x 1.90 (48)

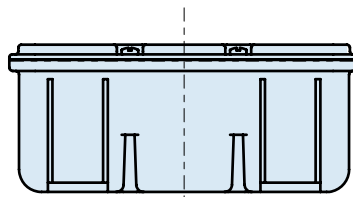
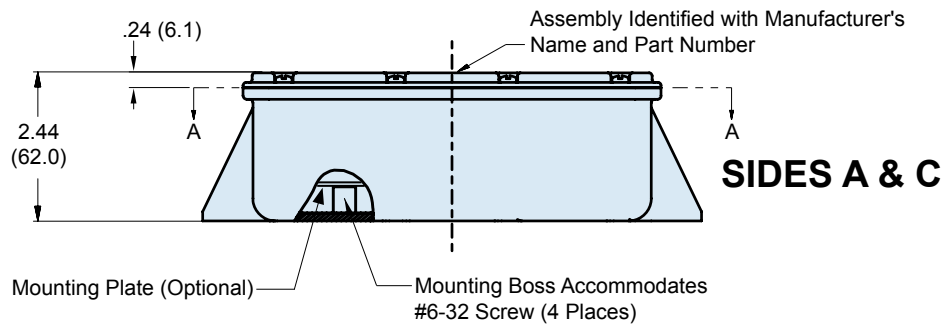
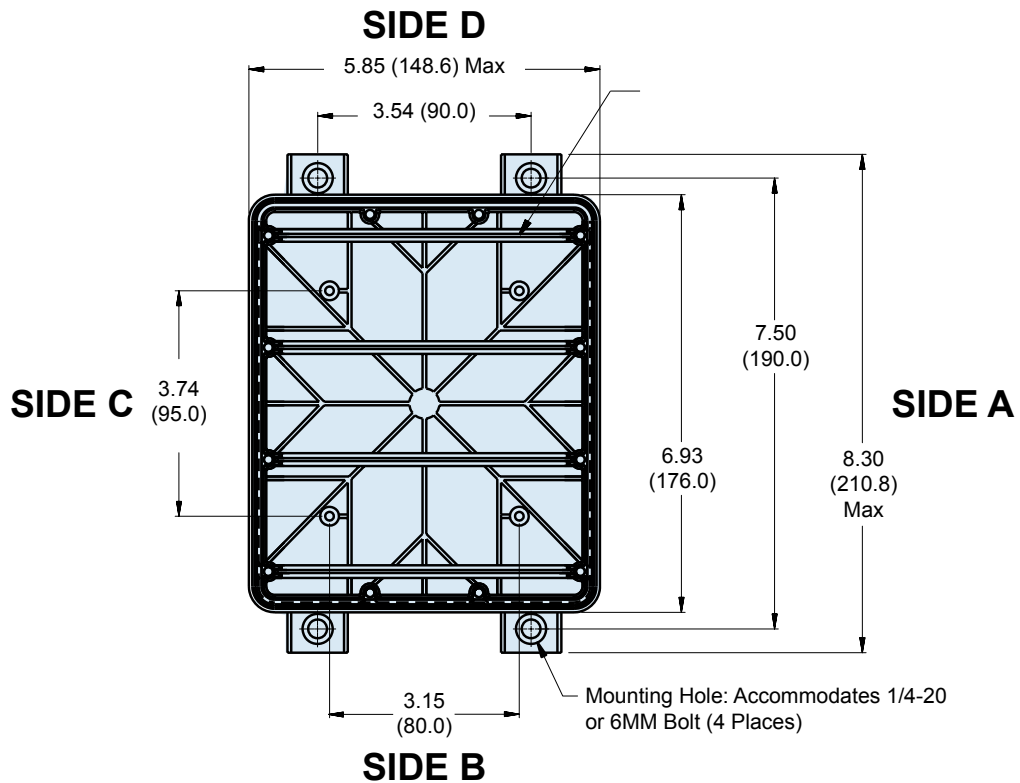
**NOTES**

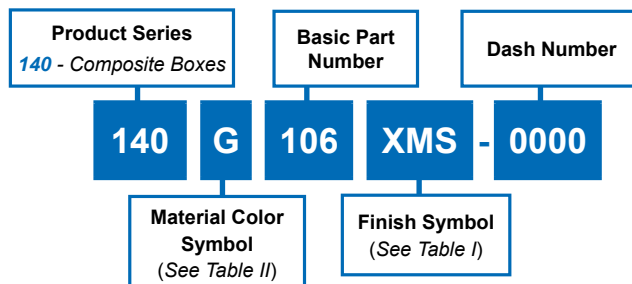
- Use Dash Number 0000 for Basic Box with No Additional Options Beyond Your Specified Finish. 0000 Basic Box Includes #6-32 UNC Fasteners.
- Box Series Numbers are for reference only. Please complete the worksheet on E-14 and call the factory for part number assignment for your specific box configuration.
- Metric dimensions (mm) are in parenthesis and for reference only

**Series 140-105  
Medium Low-Profile Junction Box**



Composite  
Junction  
Boxes





**Three-Legged  
Series 140-106  
CostSaver Composite  
Junction Box**

**TABLE II: MATERIAL COLOR & FINISH OPTIONS**

Sym	Material & Color	Finish Options
B	Thermoplastic / Black	XO and XMS
G	Thermoplastic / Grey	XO and XMS
-	Thermoplastic / NA	XM, XW and XZN

**TABLE I: FINISHES**

Symbol	Finish Description
XO	No Plating (Non-Conductive Finish)
XMS	Internal Surfaces - Electroless Nickel External Surfaces - See Table II
XM	All Surfaces – Electroless Nickel
XW	All Surfaces – Cadmium Olive Drab over Electroless Nickel
XZN	All Surfaces – Zinc Nickel/Black
XMT	2000 Hour Corrosion Resistant Ni-PTFE, Nickel-Fluorocarbon Polymer. 1000 Hour Grey™

**TABLE III: KEY DIMENSIONS**

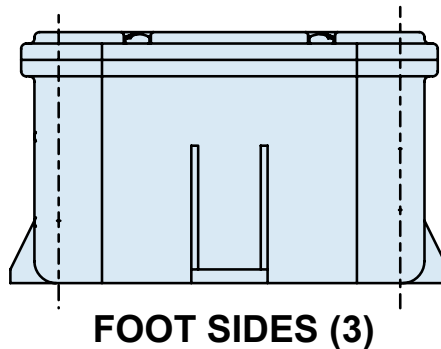
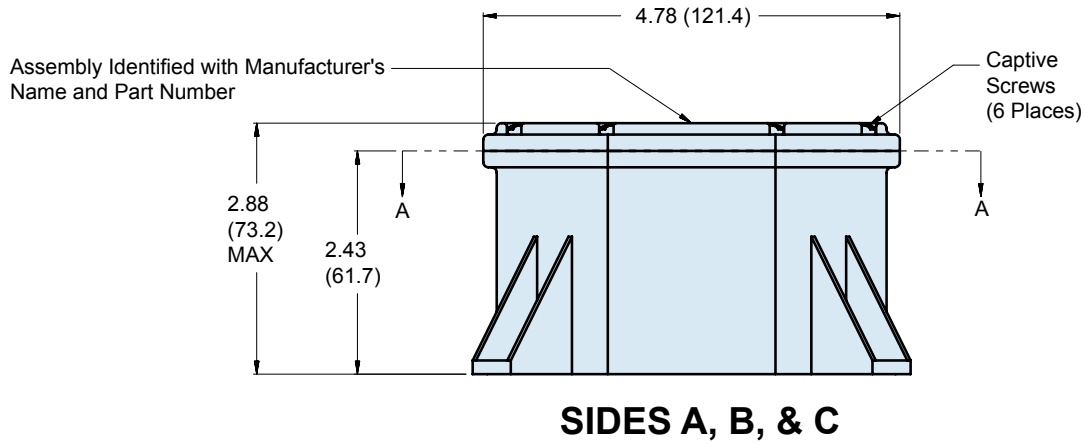
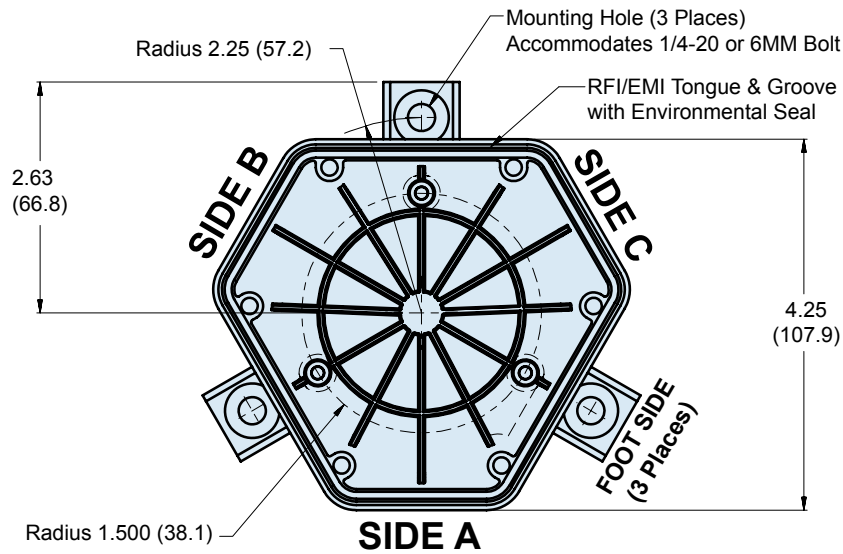
Box Series Number	External Dimensions	Internal Dimensions (with Aluminum Mounting Plate Installed, if applicable)
Three-Legged 140-106	2.88 (73.2) X 4.82 (122.4) X 4.28 (108.7)	2.50 (63.5) X 3.75 (95.3) X 3.75 (95.3)

**NOTES**

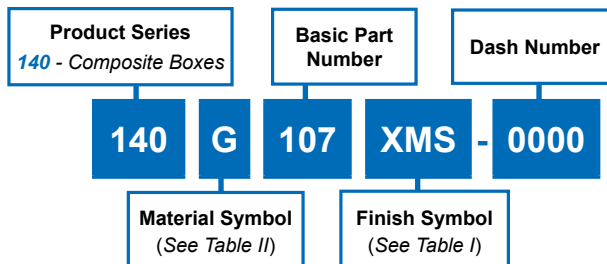
1. Use Dash Number 0000 for Basic Box with No Additional Options Beyond Your Specified Finish. 0000 Basic Box Includes #6-32 UNC Fasteners.
2. Box Series Numbers are for reference only. Please complete the worksheet on E-14 and call the factory for part number assignment for your specific box configuration.
3. Metric dimensions (mm) are in parenthesis and for reference only



Series 140-106  
Small Three-Legged Junction Box



# Series 140-107 Jumbo Junction Box



## Jumbo Series 140-107 CostSaver Composite Junction Box

**TABLE II: MATERIAL COLOR & FINISH OPTIONS**

Sym	Material & Color	Finish Options
B	Thermoplastic / Black	XO and XMS
G	Thermoplastic / Grey	XO and XMS
-	Thermoplastic / NA	XM, XW and XZN

**TABLE I: FINISHES**

Symbol	Finish Description
XO	No Plating (Non-Conductive Finish)
XMS	Internal Surfaces - Electroless Nickel External Surfaces - See Table II
XM	All Surfaces - Electroless Nickel
XW	All Surfaces - Cadmium Olive Drab over Electroless Nickel
XZN	All Surfaces - Zinc Nickel/Black
XMT	2000 Hour Corrosion Resistant Ni-PTFE, Nickel-Fluorocarbon Polymer. 1000 Hour Grey™

**TABLE III: KEY DIMENSIONS**

Box Series Number	External Dimensions	Internal Dimensions (with Aluminum Mounting Plate Installed, if applicable)
Jumbo 140-107	9.13 (232) x 11.63 (295) x 3.88 (98.5)	8.0 (203) x 10.50 (267) x 3.0 (76)

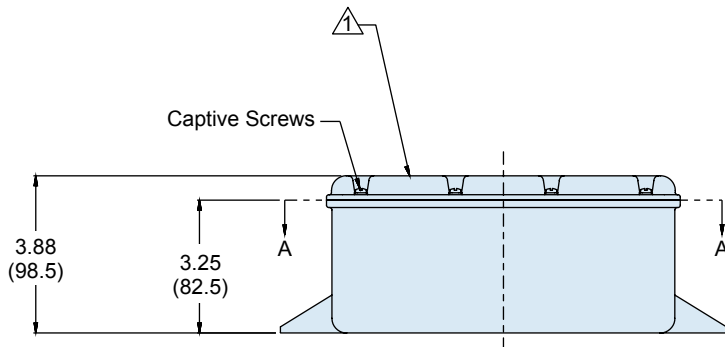
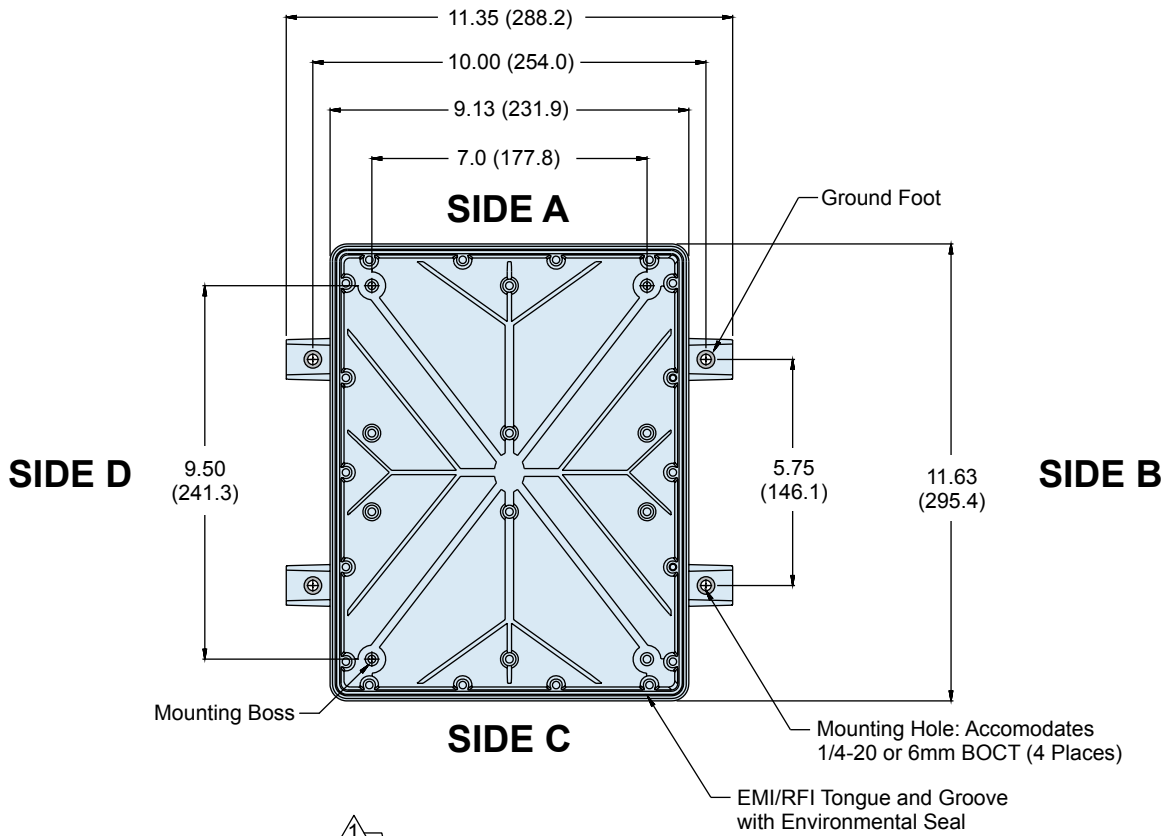
**NOTES**

- Use Dash Number 0000 for Basic Box with No Additional Options Beyond Your Specified Finish. 0000 Basic Box Includes #6-32 UNC Fasteners.
- Box Series Numbers are for reference only. Please complete the worksheet on E-14 and call the factory for part number assignment for your specific box configuration.
- Metric dimensions (mm) are in parenthesis and for reference only

Series 140-107  
Jumbo Junction Box

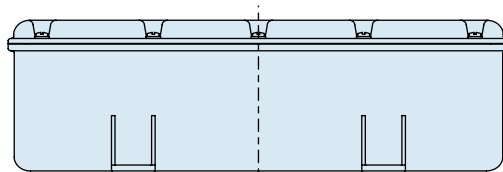


Composite  
Junction  
Boxes

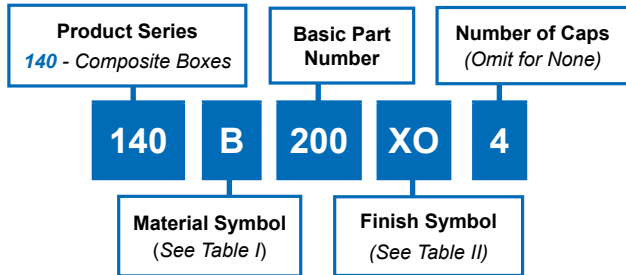


**SIDES  
A and C**

**SIDES  
B and D**

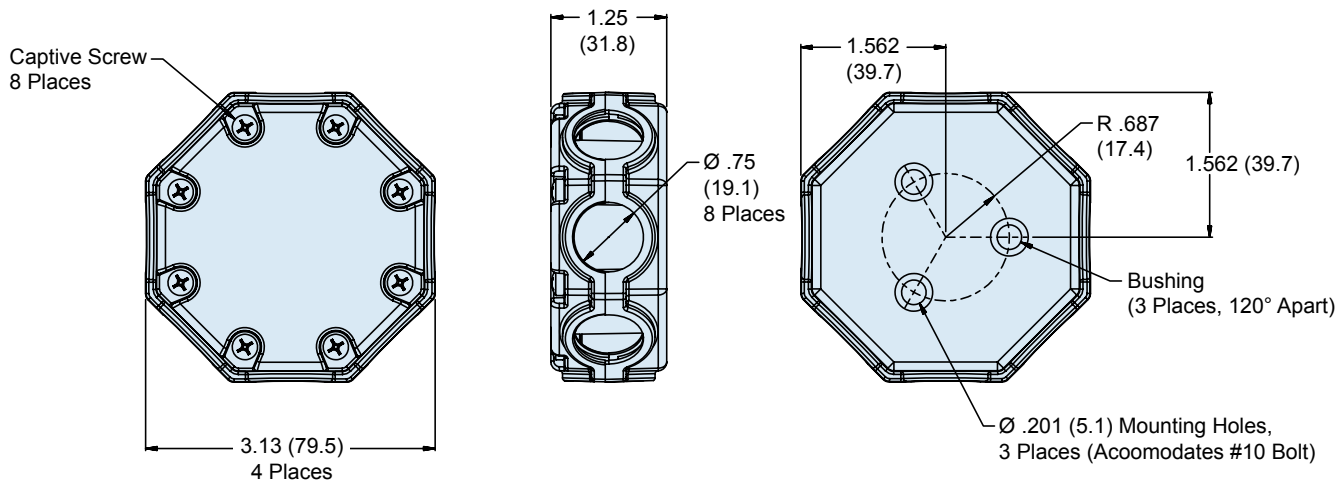


**E**



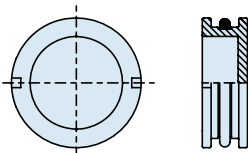
Sym	Material & Color	Finish Options
B	Thermoplastic / Black	XO and XMS
G	Thermoplastic / Grey	XO and XMS
-	Thermoplastic / NA	XM, XW and XZN

Symbol	Finish Description
XO	No Plating (Non-Conductive Finish)
XMS	Internal Surfaces - Electroless Nickel External Surfaces - See Table II
XM	All Surfaces - Electroless Nickel
XW	All Surfaces - Cadmium Olive Drab over Electroless Nickel
XZN	All Surfaces - Zinc Nickel/Black
XMT	2000 Hour Corrosion Resistant Ni-PTFE, Nickel-Fluorocarbon Polymer. 1000 Hour Grey™



### NOTES

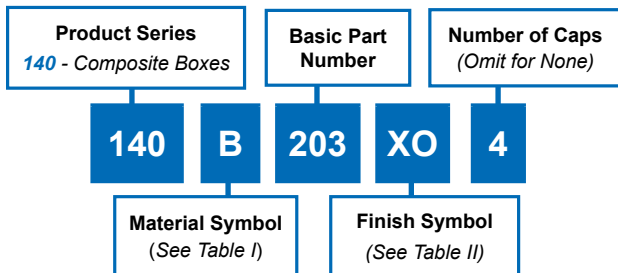
- Box series numbers are for reference only. Please complete the worksheet on E-14 and call the factory for part number assignment for your specific box configuration.
- Metric dimensions (mm) are in parentheses and are for reference only.



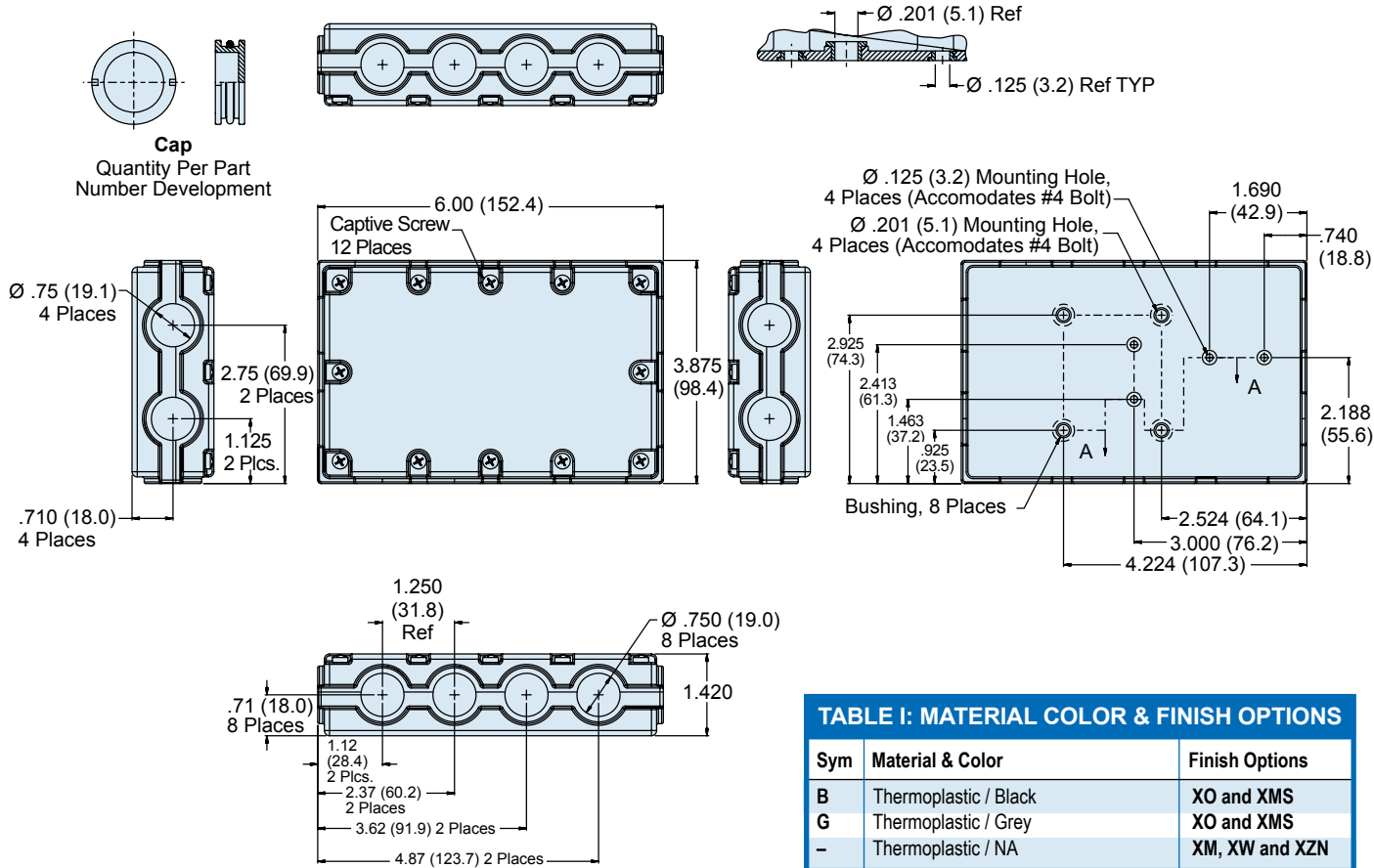
Cap

Quantity Per  
Part Number Development

# Series 140-203 12 Port Rectangular Junction Box



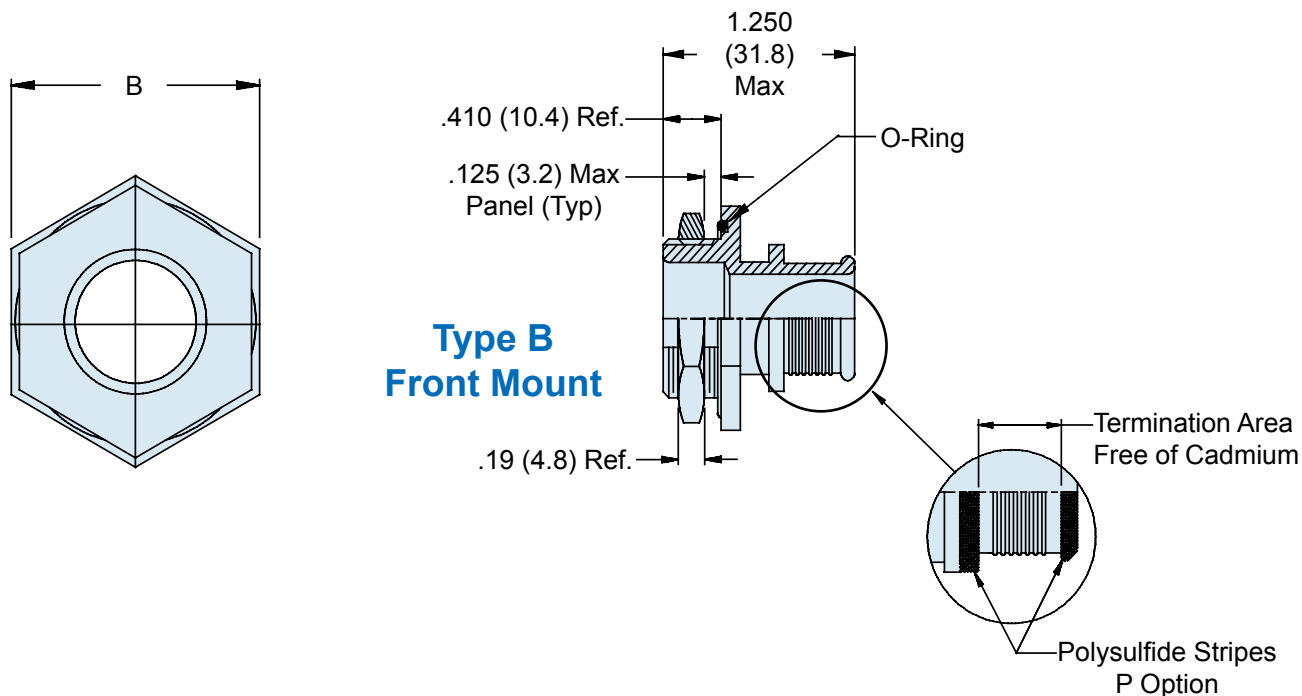
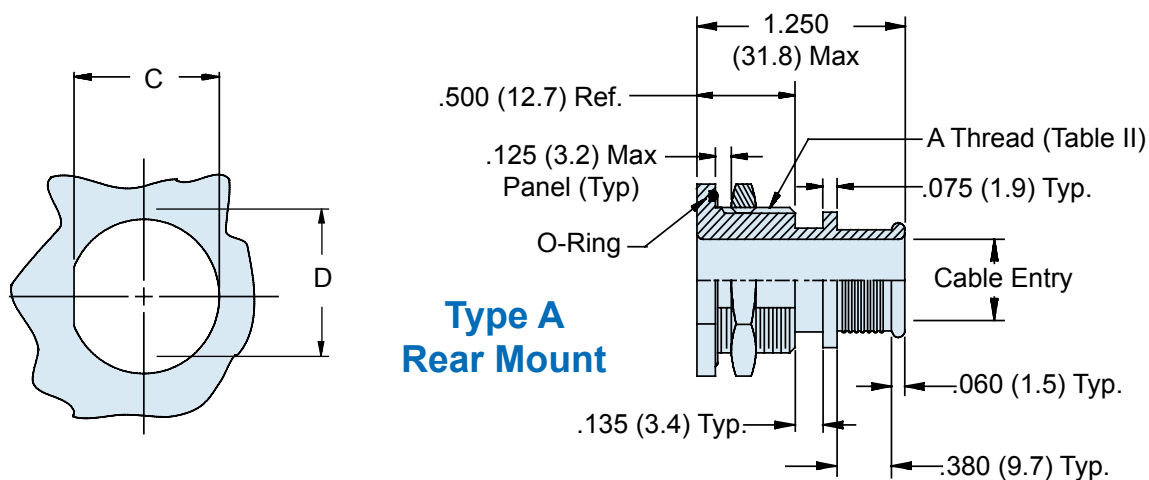
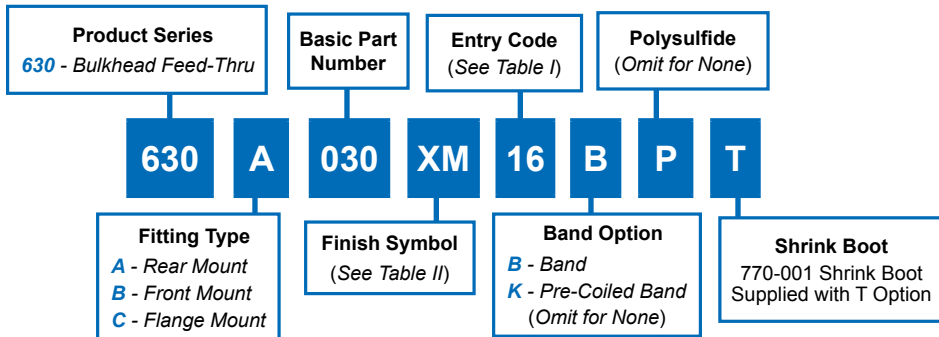
Symbol	Finish Description
XO	No Plating (Non-Conductive Finish)
XMS	Internal Surfaces - Electroless Nickel External Surfaces - See Table I
XM	All Surfaces - Electroless Nickel
XW	All Surfaces - Cadmium Olive Drab over Electroless Nickel
XZN	All Surfaces - Zinc Nickel/Black
XMT	2000 Hour Corrosion Resistant Ni-PTFE, Nickel-Fluorocarbon Polymer. 1000 Hour Grey™



Sym	Material & Color	Finish Options
B	Thermoplastic / Black	XO and XMS
G	Thermoplastic / Grey	XO and XMS
-	Thermoplastic / NA	XM, XW and XZN

- NOTES**
- Box series numbers are for reference only. Please complete the worksheet on E-14 and call the factory for part number assignment for your specific box configuration.
  - Metric dimensions (mm) are in parentheses and for reference only.



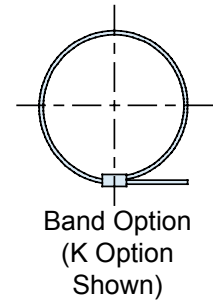
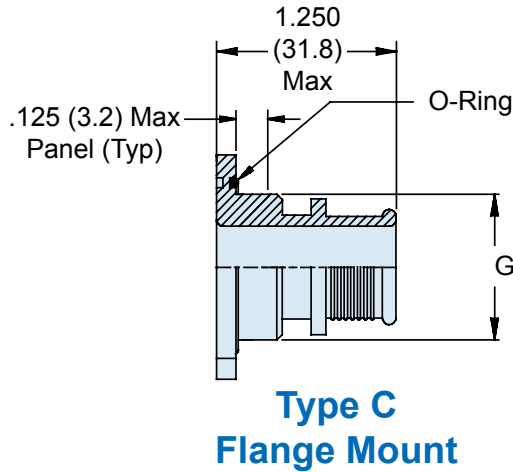
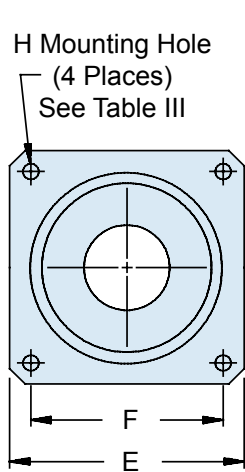


E

**630-030**  
**Composite Thru-Box, Panel and Bulkhead**  
**RFI/EMI/Environmental Banding Adapter**



Composite  
Junction  
Boxes



**TABLE I: CABLE ENTRY**

Entry Code	Cable Entry Dia	A Thread Unified	B Dim	C Flat		D Dia		E Sq	F Dim.	G Dia	
				$\pm .010$ ( $\pm .3$ )	$\pm .010$ ( $\pm .3$ )	$\pm .031$ ( $\pm .8$ )	$+.005$ ( $+.1$ ) $-.015$ ( $-.4$ )				
03	.188 (4.8)	1/2 -28	.688 (17.5)	.480 (12.2)	.515 (13.1)	.875 (22.2)	.594 (15.1)	.500 (12.7)			
04	.250 (6.4)	1/2 -28	.688 (17.5)	.480 (12.2)	.515 (13.1)	.875 (22.2)	.594 (15.1)	.500 (12.7)			
05	.313 (8.0)	5/8 -24	.813 (20.7)	.605 (15.4)	.640 (16.3)	1.000 (25.4)	.719 (18.3)	.625 (15.9)			
06	.375 (9.5)	5/8 -24	.813 (20.7)	.605 (15.4)	.640 (16.3)	1.000 (25.4)	.719 (18.3)	.625 (15.9)			
07	.438 (11.1)	3/4 -20	.938 (23.8)	.730 (18.5)	.765 (19.4)	1.094 (27.8)	.812 (20.6)	.750 (19.1)			
08	.500 (12.7)	3/4 -20	.938 (23.8)	.730 (18.5)	.765 (19.4)	1.094 (27.8)	.812 (20.6)	.750 (19.1)			
09	.563 (14.3)	7/8 -20	1.063 (27.0)	.855 (21.7)	.890 (22.6)	1.188 (30.2)	.906 (23.0)	.875 (22.2)			
10	.625 (15.9)	7/8 -20	1.063 (27.0)	.855 (21.7)	.890 (22.6)	1.188 (30.2)	.906 (23.0)	.875 (22.2)			
11	.688 (17.5)	1 -20	1.188 (30.2)	.980 (24.9)	1.015 (25.8)	1.281 (32.5)	.969 (24.6)	1.000 (25.4)			
12	.750 (19.1)	1 -20	1.188 (30.2)	.980 (24.9)	1.015 (25.8)	1.281 (32.5)	.969 (24.6)	1.000 (25.4)			
13	.813 (20.7)	1 1/8 -18	1.313 (33.4)	1.105 (28.1)	1.140 (29.0)	1.375 (34.9)	1.062 (27.0)	1.125 (28.6)			
14	.875 (22.2)	1 1/4 -18	1.438 (36.5)	1.230 (31.2)	1.265 (32.1)	1.500 (38.1)	1.156 (29.4)	1.250 (31.8)			
15	.938 (23.8)	1 1/4 -18	1.438 (36.5)	1.230 (31.2)	1.265 (32.1)	1.500 (38.1)	1.156 (29.4)	1.250 (31.8)			
16	1.000 (25.4)	1 3/8 -18	1.563 (39.7)	1.355 (34.4)	1.390 (35.3)	1.625 (41.3)	1.250 (31.8)	1.375 (34.9)			
17	1.063 (27.0)	1 3/8 -18	1.563 (39.7)	1.355 (34.4)	1.390 (35.3)	1.625 (41.3)	1.250 (31.8)	1.375 (34.9)			
18	1.125 (28.6)	1 1/2 -18	1.688 (42.9)	1.480 (37.6)	1.515 (38.5)	1.750 (44.5)	1.375 (34.9)	1.500 (38.1)			
19	1.188 (30.2)	1 1/2 -18	1.688 (42.9)	1.480 (37.6)	1.515 (38.5)	1.750 (44.5)	1.375 (34.9)	1.500 (38.1)			
20	1.250 (31.8)	1 5/8 -18	1.813 (46.1)	1.605 (40.8)	1.640 (41.7)	1.812 (46.0)	1.500 (38.1)	1.625 (41.3)			
22	1.375 (34.9)	1 3/4 -18	1.938 (49.2)	1.730 (43.9)	1.765 (44.8)	2.000 (50.8)	1.562 (39.7)	1.750 (44.5)			
24	1.500 (38.1)	2 -18	2.188 (55.6)	1.980 (50.3)	2.015 (51.2)	2.250 (57.2)	1.750 (44.5)	2.000 (50.8)			
26	1.625 (41.3)	2 -18	2.188 (55.6)	1.980 (50.3)	2.015 (51.2)	2.250 (57.2)	1.750 (44.5)	2.000 (50.8)			
28	1.750 (44.5)	2 1/4 -16	2.438 (61.9)	2.230 (56.6)	2.265 (57.5)	2.500 (63.5)	1.938 (49.2)	2.250 (57.2)			

**TABLE II**

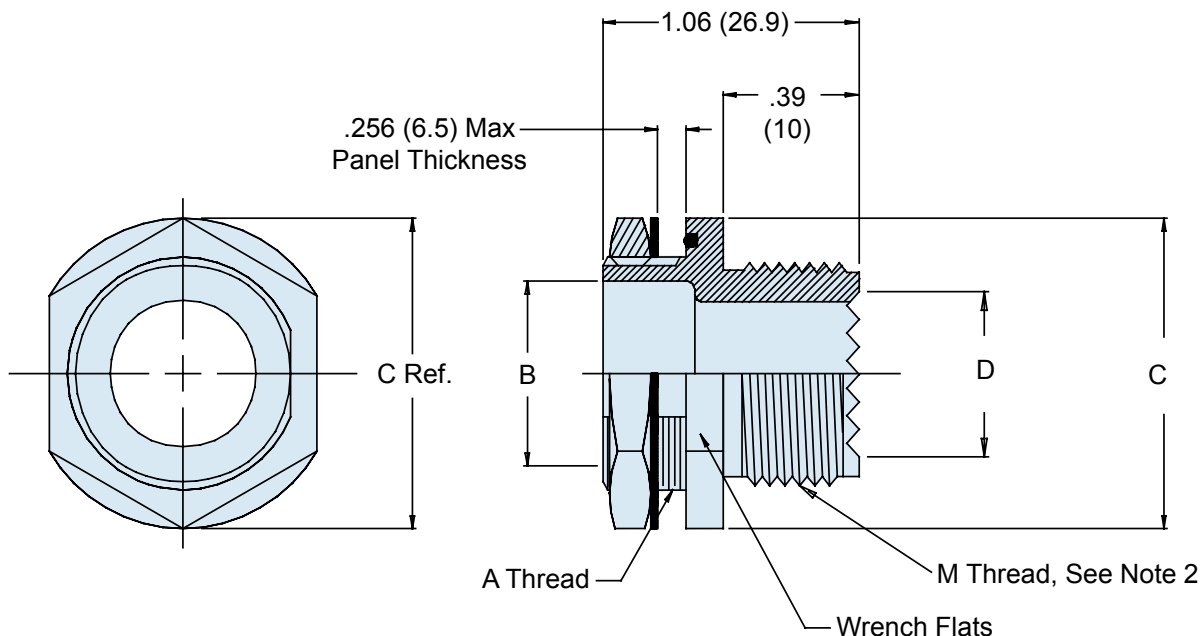
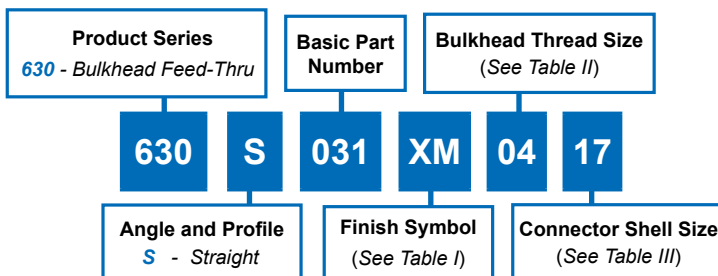
Symbol	Finish Description
XM	2000 Hour Corrosion Resistant Electroless Nickel
XMT	2000 Hour Corrosion Resistant Ni-PTFE, Nickel-Fluorocarbon Polymer. 1000 Hour Grey™
XW	2000 Hour Corrosion Resistant Cadmium/Olive Drab over Electroless Nickel

**TABLE III: MOUNTING**

	H Dia
<b>Dash Nos.</b>	<b>+ .015 (+ .4)</b> <b>- .000 (- .0)</b>
03-17	.125 (3.2)
18-20	.156 (4.0)
22-28	.188 (4.8)

**APPLICATION NOTES**

- Metric dimensions (mm) are in parentheses and are for reference only
- Consult factory for shrink boot to be supplied with part.



E

**APPLICATION NOTES**

1. Metric dimensions (mm) are in parentheses and are for reference only.
2. MIL-DTL-38999 Series 3 & 4 Accessory Interface, Glenair Code H.



**630-031**  
**Composite Thru-Box, Panel and Bulkhead**  
**Universal Environmental Adapter**



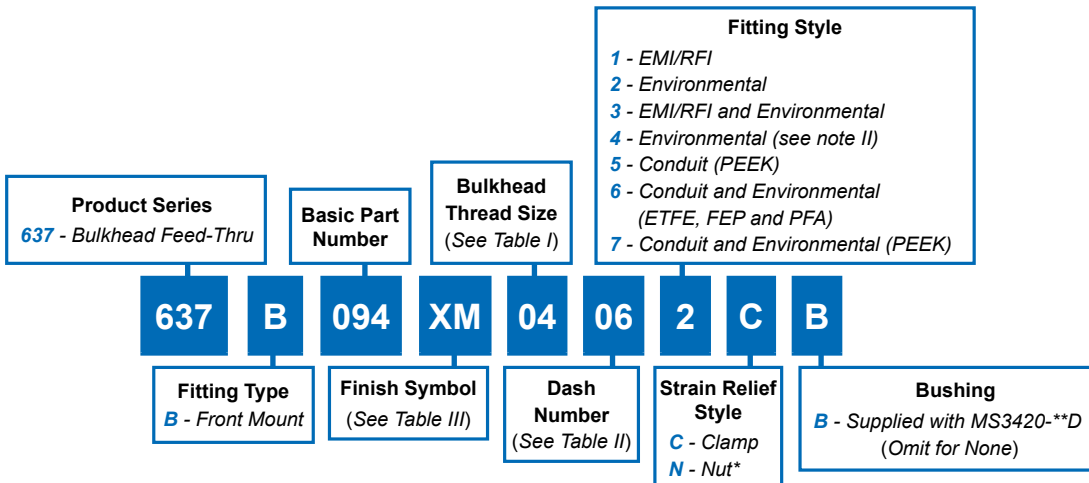
TABLE I	
Symbol	Finish Description
XM	2000 Hour Corrosion Resistant Electroless Nickel
XMT	2000 Hour Corrosion Resistant Ni-PTFE, Nickel-Fluorocarbon Polymer. <i>1000 Hour Grey™</i>
XW	2000 Hour Corrosion Resistant Cadmium/Olive Drab over Electroless Nickel

TABLE II: BULKHEAD THREAD SIZE						
Dash No.	A Thread ISO Metric	B Dia. Min.	C Max.	Max Entry Table 3		
01	M 16 x 1.5-6g	.394 (10.0)	1.070 (27.2)	11		
02	M 20 x 1.5-6g	.551 (14.0)	1.200 (30.5)	13		
03	M 27 x 2.0-6g	.866 (22.0)	1.510 (38.4)	21		
04	M 36 x 2.0-6g	1.181 (30.0)	2.010 (51.1)	25		

TABLE III: CONNECTOR SHELL SIZE			
Shell Size	M Thread ISO Metric	D Min	
09	M 12 x 1.0-6g	.250	(6.4)
11	M 15 x 1.0-6g	.375	(9.5)
13	M 18 x 1.0-6g	.500	(12.7)
15	M 22 x 1.0-6g	.625	(15.9)
17	M 25 x 1.0-6g	.750	(19.1)
19	M 28 x 1.0-6g	.812	(20.6)
21	M 31 x 1.0-6g	.938	(23.8)
23	M 34 x 1.0-6g	1.062	(27.0)
25	M 37 x 1.0-6g	1.188	(30.2)

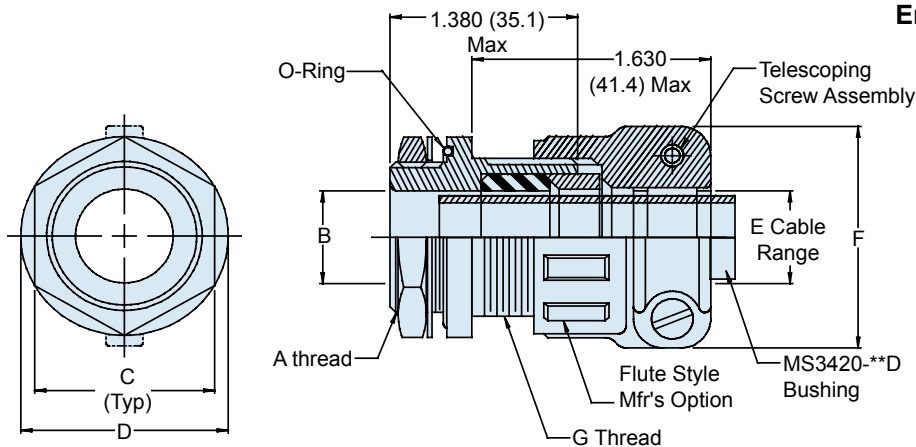


# 637-094 Composite Box Conduit or Cable Feed-Through Adapter Series

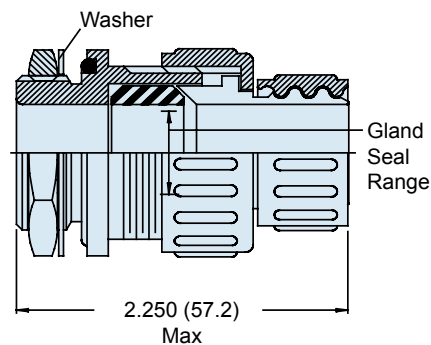


\*(for styles A, B and C only)

**Type B Environmental  
Style 2**

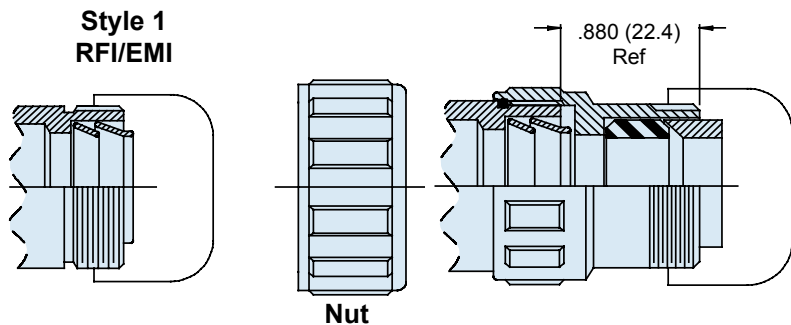


**Type B  
Environmental Conduit Adapter  
Style 6 or 7**

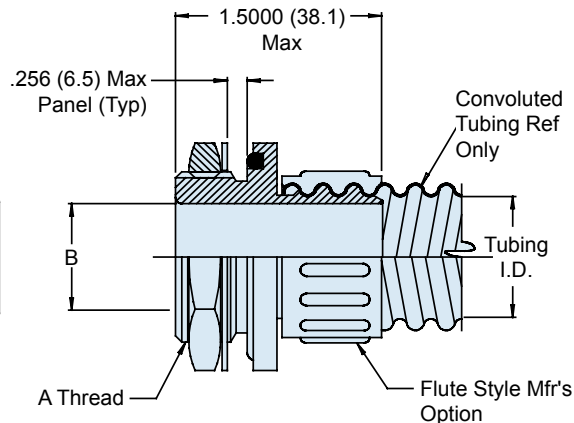


**E**

**Type B  
RFI/EMI & Environmental  
Style 3**



**Type B Conduit Adapter  
Style 5**



**637-094**  
**Composite Box Conduit or Cable**  
**Feed-Through Adapter Series**



Composite  
Junction  
Boxes

**TABLE I: BULKHEAD THREAD SIZE**

Dash No.	A Thread ISO Metric	B Ref Diameter	C	D Max Diameter	Max Entry Table II
01	M16 x 1.5-6g	.55 (14.0)	.875 (22.2)	1.06 (27.2)	06
02	M20 x 1.5-6g	.61 (15.5)	1.062 (27.0)	1.19 (30.5)	10
03	M27 x 2.0-6g	.86 (21.8)	1.375 (34.9)	1.50 (38.4)	16
04	M36 x 2.0-6g	1.21 (30.7)	1.750 (44.5)	2.00 (51.1)	20
05	1-20 UNEF-2A	.78 (19.8)	1.250 (31.8)	1.38 (35.3)	12

**TABLE II: CONNECTOR SHELL SIZE ORDER NUMBER**

Dash No.	E		F Max	G Thread		Ref. Conduit Size Styles 5, 6 & 7
	Min	Max		Unified Class 2A	MS3420-**D	
04	.188 (4.8)	.312 (7.9)	1.150 (29.2)	11/16-24	-04	14
06	.291 (7.1)	.438 (11.1)	1.270 (32.3)	13/16-20	-06	16
10	.375 (9.5)	.610 (15.5)	1.460 (37.1)	1 1/16-18	-06 & -10	24
12	.438 (11.1)	.750 (19.1)	1.620 (41.1)	1 1/4-18	-08 & -12	28
16	.625 (15.9)	.860 (21.8)	1.770 (44.9)	1 1/2-18	-12 & -16	32
20	.875 (22.2)	1.210 (30.7)	2.060 (52.3)	1 13/16-16	-16 & -20	40

**E**

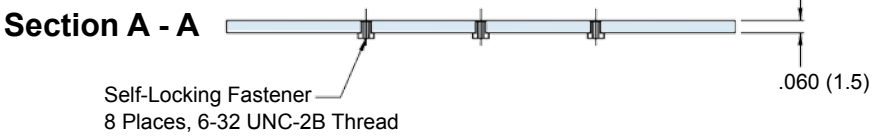
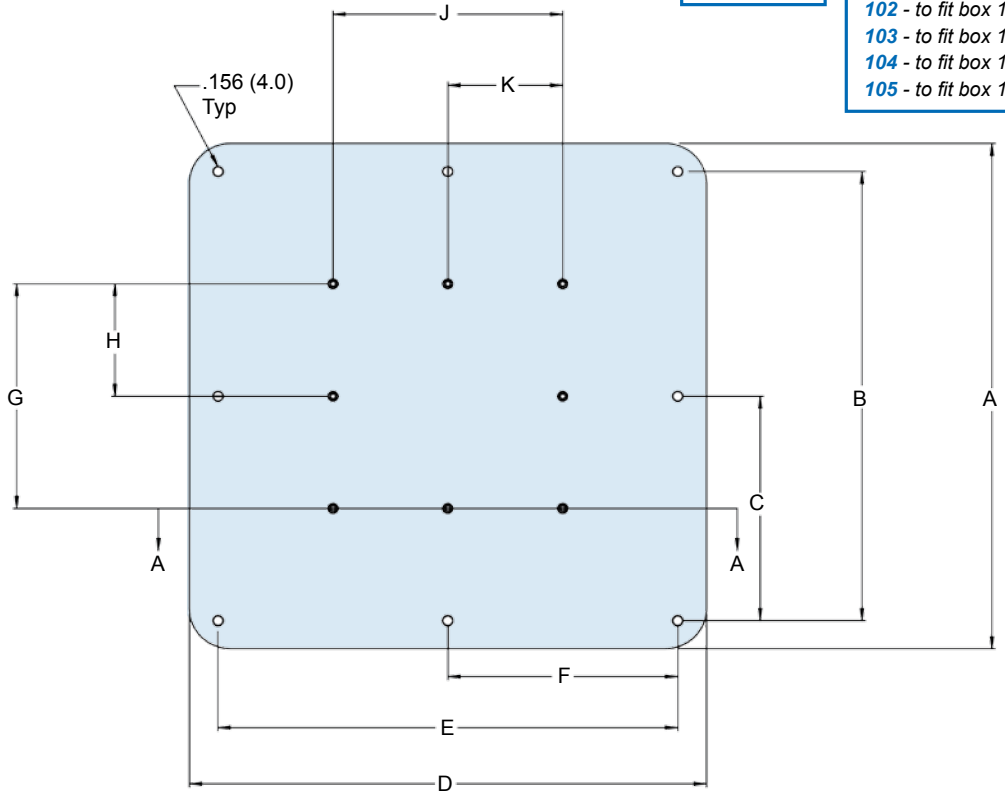
**TABLE II**

Symbol	Finish Description
XB	No Plating - Black Color (Non-Conductive Finish)
XM	2000 Hour Corrosion Resistant Electroless Nickel
XMT	2000 Hour Corrosion Resistant Ni-PTFE, Nickel-Fluorocarbon Polymer. <i>1000 Hour Grey™</i>
XO	No Plating - Brown Color (Non-Conductive Finish)
XW	2000 Hour Corrosion Resistant Cadmium/Olive Drab over Electroless Nickel

# 687-466 Terminal Rail and Block Mounting Plate To Fit Rectangular Boxes

Finish	Material	Finish Description
M	Aluminum Alloy	Electroless Nickel
Z1	Stainless Steel	Passivate

<b>Product Series</b> 687 - Box Mounting Plate		<b>Material and Finish</b> (See Table I)	
<b>687</b>	<b>-</b>	<b>466</b>	<b>Z1 103</b>
<b>Basic Part Number</b>		<b>Dash Number</b>	
		101 - to fit box 140-101 102 - to fit box 140-102 103 - to fit box 140-103 104 - to fit box 140-104 105 - to fit box 140-105	



E

Dash No.	A Dim	B Dim	C Dim	D Dim	E Dim	F Dim	G Dim	H Dim	J Dim	K Dim
101	3.890 (98.8)	3.000 (76.2)	N/A	4.680 (118.9)	4.000 (101.6)	N/A	1.800 (45.7)	.900 (22.9)	2.500 (63.5)	1.250 (31.8)
102	4.650 (118.1)	4.000 (101.6)	N/A	5.500 (139.7)	5.000 (127.0)	N/A	3.160 (80.3)	1.580 (40.1)	3.160 (80.3)	1.580 (40.1)
103	7.870 (199.9)	7.000 (177.8)	3.500 (88.9)	7.870 (199.9)	7.000 (177.8)	3.500 (88.9)	3.980 (101.1)	1.990 (50.5)	3.980 (101.1)	1.990 (50.5)
104	4.650 (118.1)	3.750 (95.3)	N/A	4.650 (118.1)	3.750 (95.3)	N/A	2.330 (59.2)	1.160 (29.5)	2.330 (59.2)	1.160 (29.5)
105	4.500 (114.3)	3.150 (80.0)	N/A	5.750 (146.1)	3.740 (95.0)	N/A	3.160 (80.3)	1.580 (40.1)	3.160 (80.3)	1.580 (40.1)
107	7.688 (195.3)	7.000 (177.8)	3.500 (88.9)	10.188 (258.8)	9.500 (241.3)	3.750 (95.3) / 5.75 (146.1)	—	—	—	—

Metric Dimensions (mm) are in parentheses and are for reference only

# 687-305-22 Round Internal Mounting Plate To Fit Three-Legged Boxes



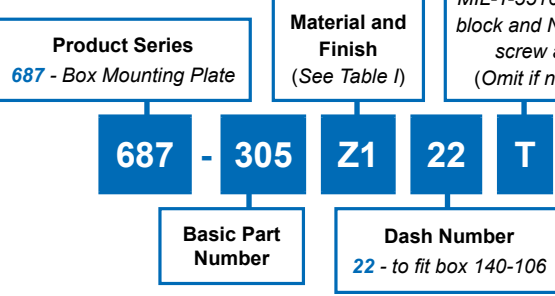
Composite  
Junction  
Boxes

**TABLE I: MATERIALS AND FINISH**

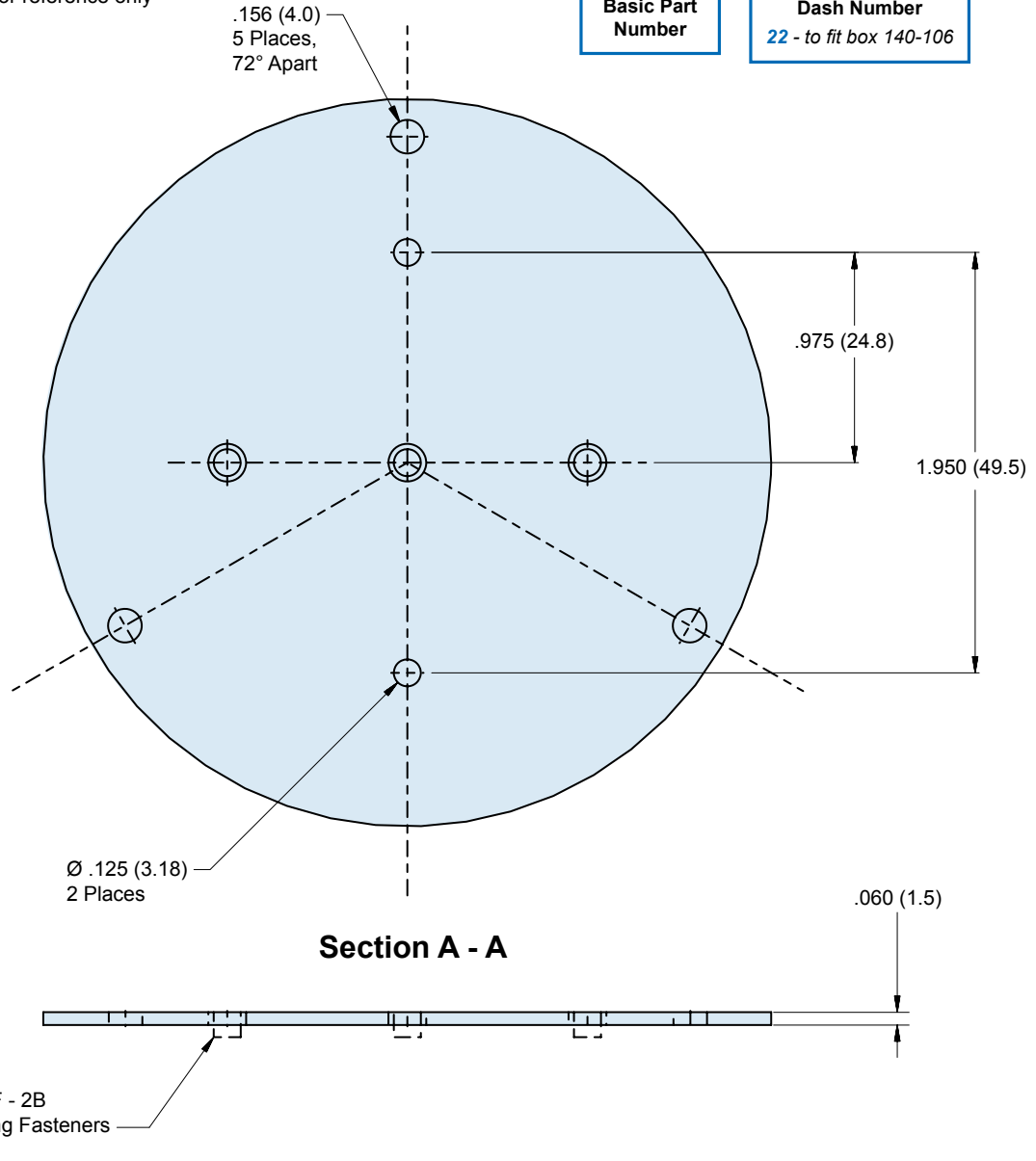
Finish	Material	Finish Description
M	Aluminum Alloy	Electroless Nickel
Z1	Stainless Steel	Passivate

**Terminal Block Option**

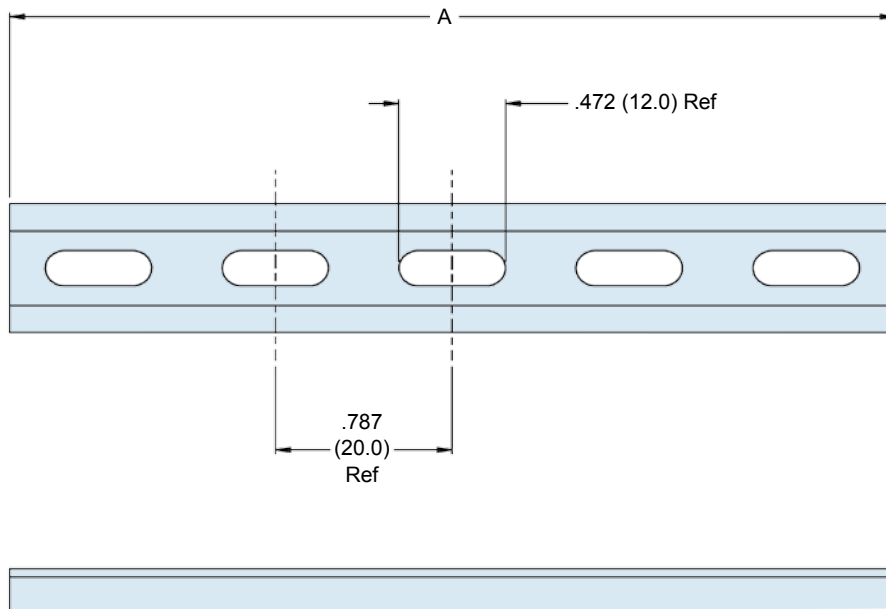
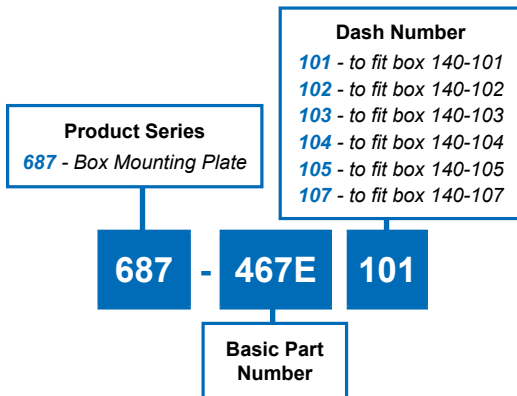
T - Plate supplied with MIL-T-55164/15 terminal block and NAS720C6-12 screw assembly (Omit if not required)



Metric Dimensions (mm) are in parentheses and are for reference only



# 687-467 Slotted Terminal Block Mounting Rail



**TABLE I: MATERIAL AND FINISH**

Finish	Material	Finish Description
E	Aluminum Alloy	Iridite

**TABLE II: DIMENSIONS**

Dash No.	A ± .040 (1.000)	Use with Box	Use with Mounting Plate
101	3.750 (95.5)	140-101	687-466-101
102	4.620 (117.3)	140-102	687-466-102
103	6.249 (158.5)	140-103	687-466-103
104	4.650 (118.2)	140-104	687-466-104
105	4.500 (114.3)	140-105	687-466-105
106	2.500 (63.5)	140-106	687-305-22
107	TBD	140-107	687-466-107

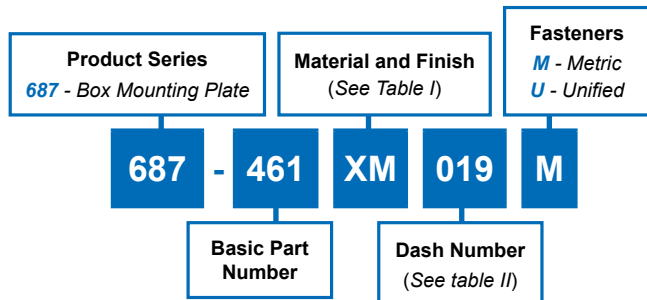
Metric Dimensions (mm) are in parentheses and are for reference only

E

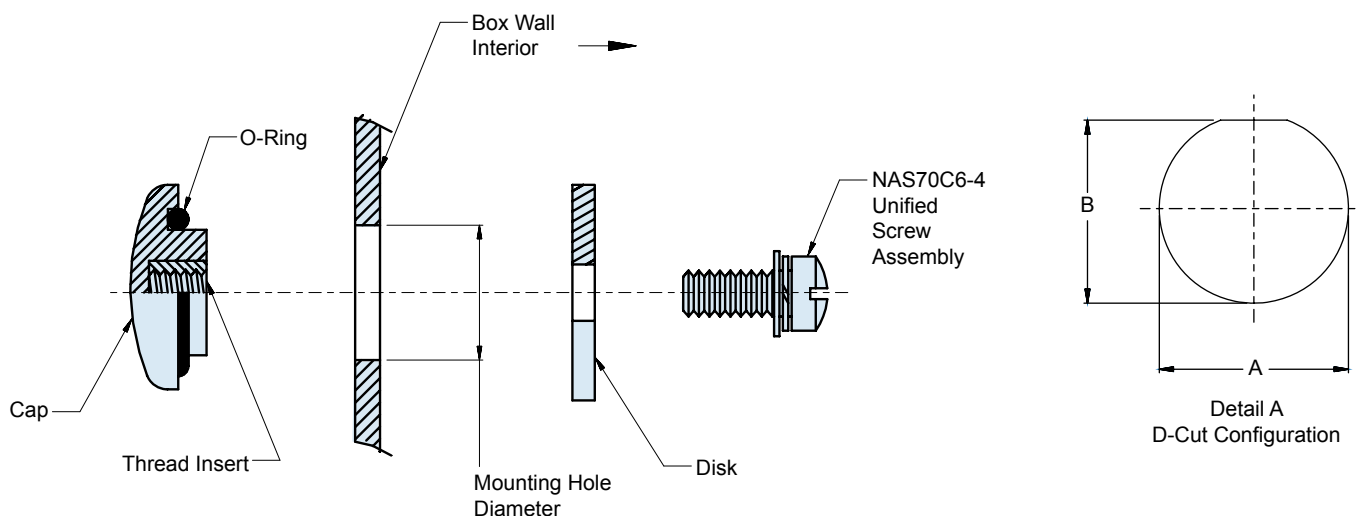
# 687-461 Hole Cap Assembly



Composite  
Junction  
Boxes



Dash Number	A Mounting Hole Dia.	D Dim.	Thread Size, Box Components, Ref.	
016	.646	N/A	M16	5/8
017	.725	N/A	M18	
018	.765	N/A		3/4
019	.802	N/A	M20	
020	.890	N/A		7/8
021	.945	N/A		15/16
022	1.015	N/A		1.0
023	1.077	N/A	M27	
027	1.328	N/A		15/16
028	1.203	N/A	M30	13/16
029	1.438	N/A	M36	
030	.640	.595	See Detail A	
031	1.000	.968	See Detail A	
032	.755	.691	See Detail A	



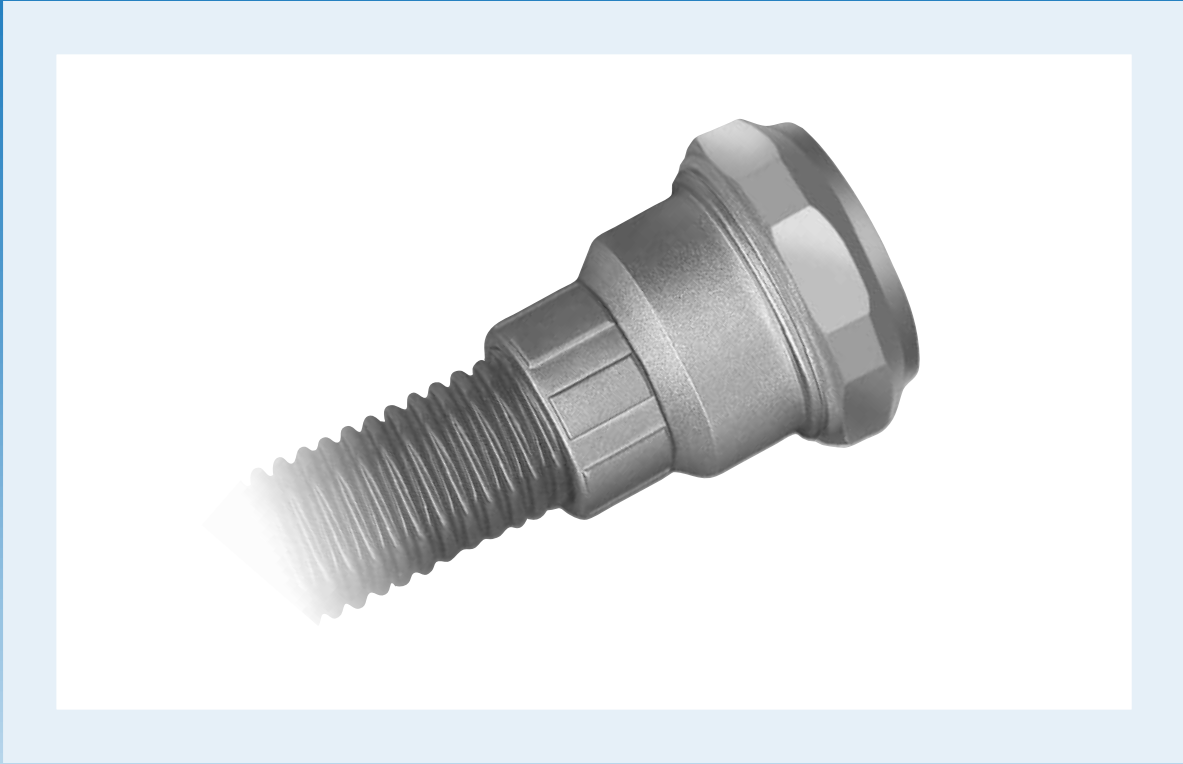
Symbol	Material	Finish Description
XO	PEI 30% Glass Filled Composite Thermoplastic	No Plating – Color Light Grey (Non-Conductive Finish)
XB		No Plating – Color Black (Non-Conductive Finish)
XM		Conductive – Electroless Nickel
XZN		Conductive – Zinc Nickel, Black

Dash No.	Mounting Hole Dia.
016	.646 (16.4)
017	.725 (18.4)
018	.765 (19.4)
019	.802 (20.4)
020	.890 (22.6)
022	1.015 (25.8)
023	1.077 (27.4)
027	1.328 (33.7)
029	1.438 (36.5)

Metric Dimensions (mm) are in parentheses and are for reference only

E

# A New Way to Make Ends Meet



## Glenair G-Load Coupling

**F**or most applications, our standard self-locking coupling nuts with their familiar clicking action are a sure bet. But for situations where a helping hand is required to ensure the backshell coupling nut is tightened securely against connector interlocking teeth, Glenair is proud to offer our patented G-Load Coupler.

G-Load Coupling uses concentrically formed spring arms to push the backshell against the connector—aligning and seating the teeth and eliminating part loosening problems. The secret is in the G-Load patented low-torque performance: The G-Load Coupler actually

becomes tighter as the coupling reaches its final, full-thread engagement. And the G-Load Coupler remains tight even at low torque levels—eliminating vibration-related decoupling problems. Best of all, the G-Load Coupler can be installed again and again to full torque without degrading performance. Naturally, the entire mechanism is made from composite materials to eliminate maintenance and reduce weight.

So, for that little extra peace of mind that comes from couplers that won't rattle loose, call the factory and enquire about the new G-Load Coupler from Glenair.



1211 Air Way · Glendale, California 91201-2497

Telephone: 818-247-6000 · Facsimile: 818-500-9912 · E-mail: [sales@glenair.com](mailto:sales@glenair.com)

United States · United Kingdom · Germany · Nordic · France · Italy · Spain · Japan

[www.glenair.com](http://www.glenair.com)



## Glenair Environmental Class MIL-DTL-38999 Type Connectors in Composite Thermoplastic are Built for a Broad Range of Harsh-Environment Applications

### Product Applications

Glenair is recognized as trusted supplier of harsh environment electrical connectors built to the MIL-DTL-38999 standard. This section of the catalog presents a selection of the environmental class MIL-DTL-38999 Series III type solutions produced by Glenair in composite thermoplastic.

### Available Insert Arrangements

Based on industry-standard specifications, Glenair's MIL-DTL-38999 derivative environmental class connectors are supplied with insert arrangements IAW MIL-STD-1560, or appropriate sub-sets depending on connector series. Consult factory for available insert arrangements.

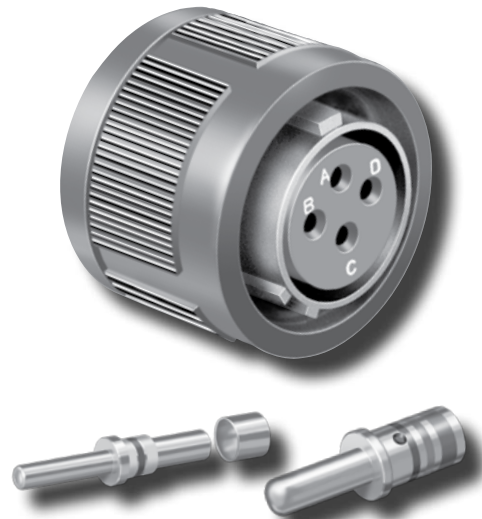


TABLE I: MATERIALS

Shell, Barrel, and Coupling Nut	30% glass filled Ultem® Composite Thermoplastic
Front and Rear Insulators	Glass-filled LCP in accordance with MIL-M-24519, Type GLP-30F
Contact Retention Clip	Beryllium copper, heat-treated, unplated
Grommet, Peripheral Seal and Interfacial Seal	Blended elastomer, 30% silicone per ZZ-R-765, 70% fluorosilicone per MIL-R-25988
Pin / Socket Contacts (Environmental)	Copper Alloy / Gold Plate - per M39029 / AS39029
Adhesives	Silicone and epoxy
Potting Compound: PCB and Solder Cup	High-strength epoxy, Hysol EE4215.

TABLE II: POPULAR ENVIRONMENTAL CLASS CONNECTOR FINISHES

Plating Code	Material	Finish	Specification
XM	Composite	Electroless Nickel	AMS-C-26074
XMT	Composite	Ni-PTFE <i>1000 Hour Grey™</i> (Nickel Fluorocarbon Polymer)	MIL-DTL-38999L (2000 Hour Salt Spray)
XW	Composite	Cadmium Olive Drab over Electroless Nickel	AMS-QQ-P-416, over AMS-C-26074 (1000 Hour Salt Spray)



9-35



9-98



11-2



11-4



11-5



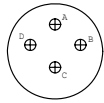
11-35



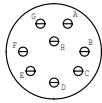
11-98



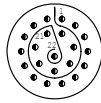
11-99



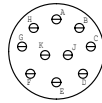
13-4



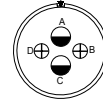
13-8



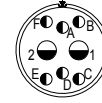
13-35



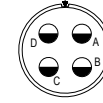
13-98



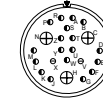
13L-13



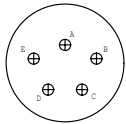
13L-26



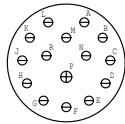
15L-04



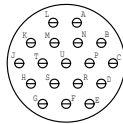
15L-23



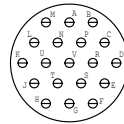
15-5



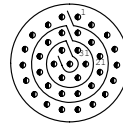
15-15



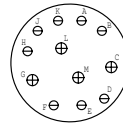
15-18



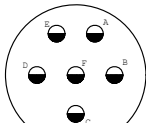
15-19



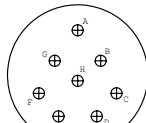
15-35



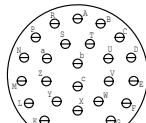
15-97



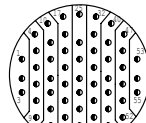
17-6



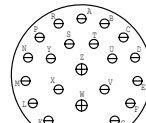
17-8



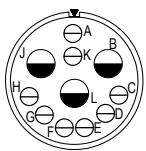
17-26



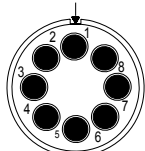
17-35



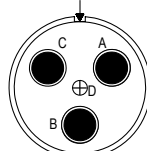
17-99



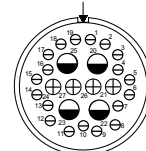
17-11



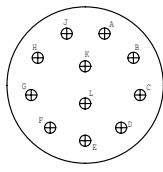
17L-88



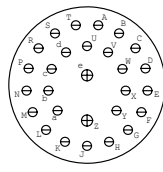
19L-04



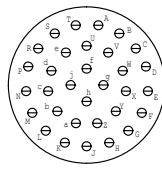
21L-29



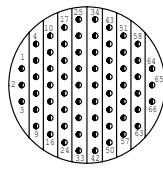
19-11



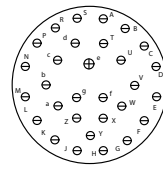
19-28



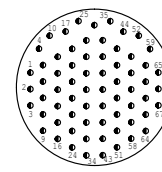
19-32



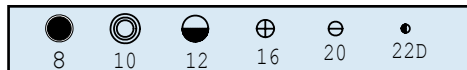
19-35



19-30

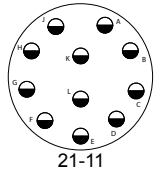


19-45

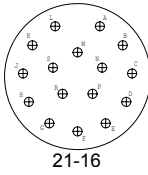


Consult factory for available insert arrangements.

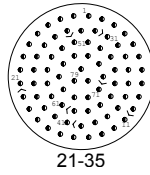
MIL-DTL-38999 Series III Type  
Environmental Class Connectors  
Insert Arrangements (IAW MIL-STD-1560 and JSFD08)



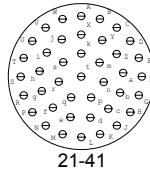
21-11



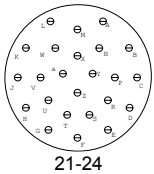
21-16



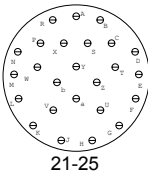
21-35



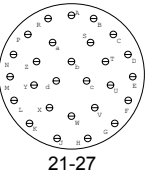
21-41



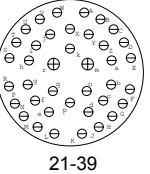
21-24



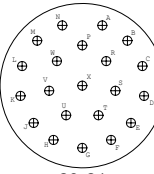
21-25



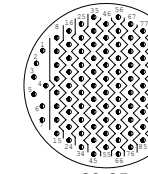
21-27



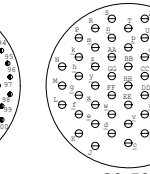
21-39



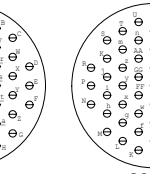
23-21



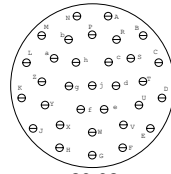
23-35



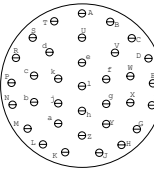
23-53



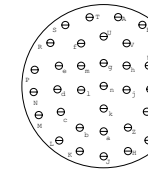
23-55



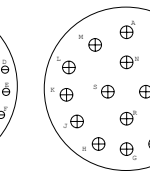
23-32



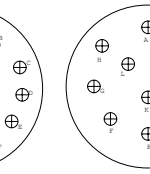
23-34



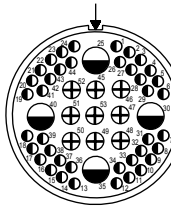
23-36



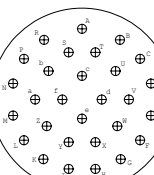
23-97



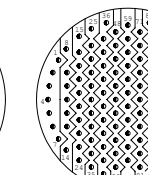
23-99



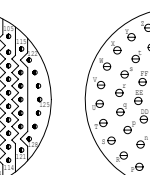
23L-54



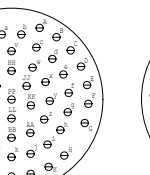
25-29



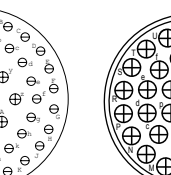
25-35



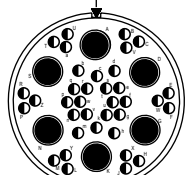
25-61



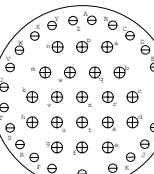
25-4



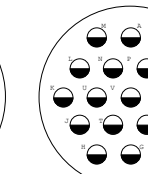
25-37



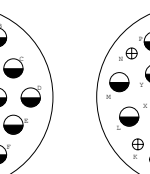
25C-17



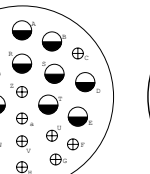
25-43



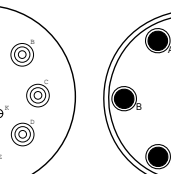
25-19



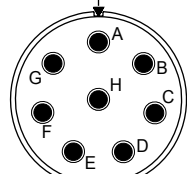
25-24



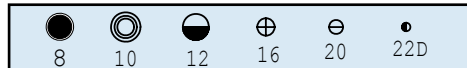
25-11



25L-7



25Q-08



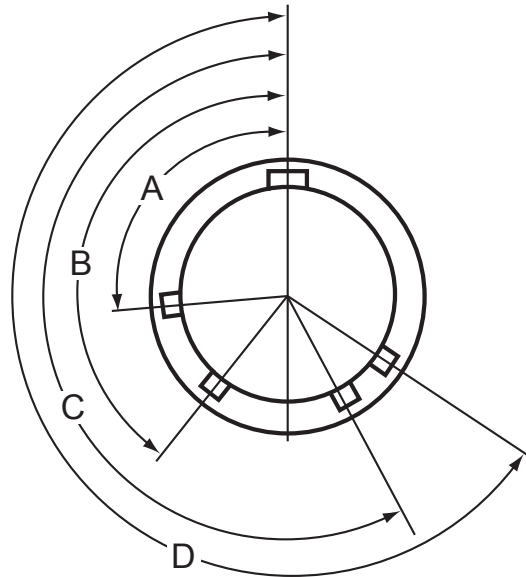
Consult factory for available insert arrangements.



**Shell Polarization Table: Receptacle Face**

Shell Size Code	Shell Size	Keyway	A°	B°	C°	D°
A	09	N	105	140	215	265
		A	102	132	248	320
		B	80	118	230	312
		C	35	140	205	275
		D	64	155	234	304
B C D	11 13 15	N	95	141	208	236
		A	113	156	182	292
		B	90	145	195	252
		C	53	156	220	255
		D	119	146	176	298
E F G H J	17 19 21 23 25	N	80	142	196	293
		A	135	170	200	310
		B	49	169	200	244
		C	66	140	200	257
		D	62	145	180	280
E	79	153	197	272		

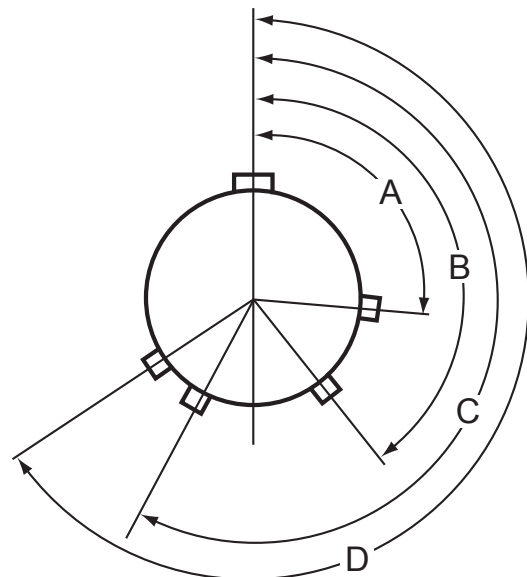
**Receptacle View**



**Shell Polarization Table: Plug Face**

Shell Size Code	Shell Size	Keyway	A°	B°	C°	D°
A	09	N	105	140	215	265
		A	102	132	248	320
		B	80	118	230	312
		C	35	140	205	275
		D	64	155	234	304
B C D	11 13 15	N	95	141	208	236
		A	113	156	182	292
		B	90	145	195	252
		C	53	156	220	255
		D	119	146	176	298
E F G H J	17 19 21 23 25	N	80	142	196	293
		A	135	170	200	310
		B	49	169	200	244
		C	66	140	200	257
		D	62	145	180	280
E	79	153	197	272		

**Plug View**

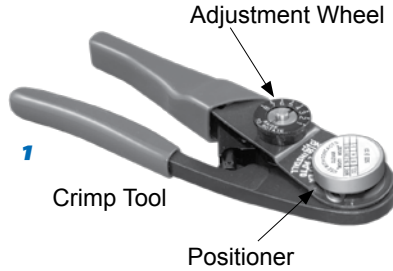


# Crimp Contact Termination Instructions



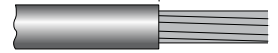
## How To Terminate, Install and Remove Crimp Contacts

**1 Set Up Series M22520 Crimp Tool.** See pin and socket contact selection guide for correct tools based on contact part numbers and tool codes. Install proper positioner into crimp tool. The label on the positioner shows the proper tool setting for each wire size. Turn the adjustment wheel to the correct setting.



For Wire Sizes 22, 22M, 22D

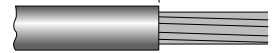
1/8" - 5/32"  
(3.2 - 3.9)



2

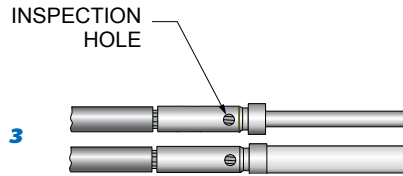
For Wire Sizes 10, 12, 16, 20

7/32" - 1/4"  
(5.6 - 6.4)



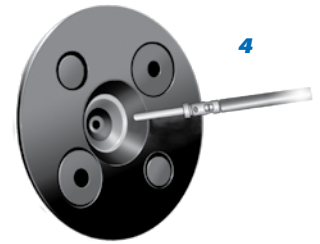
**2 Strip Wire.** Remove wire insulation, taking care to avoid nicking or cutting wire strands. Strip wire to length shown. Holding wire by insulation, twist strands together to form a neat bundle.

**3 Insert wire** into contact. The wire should be visible in the inspection hole.



3

**4** Insert wire and contact into crimp tool as shown. Make sure that the contact is fully inserted into the tool. Squeeze handle completely. The ratchet mechanism will not allow a partial crimp. Release handle and remove contact.



4

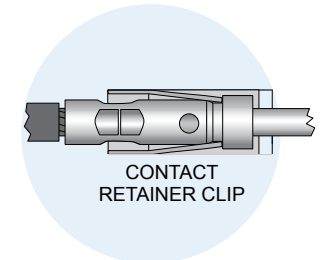
**5 Inspect crimped contact.** Wire should be fully inserted and the crimp should be uniform in appearance.



5

**6 Install contact into connector.** Slide colored end of insertion/extraction tool over wire insulation and slide the tool forward until it bottoms against the contact shoulder. Insert tool/contact/wire into contact cavity, being careful to avoid damage by properly aligning the contact with the cavity. Push forward until contact retention clip snaps into position. Remove tool. Gently pull on wire to confirm contact retention. Fill unused contact cavities with uncrimped contacts followed by the proper MS27488 sealing plug. For potted cable applications, install crimped-wire contacts in all unused cavities and terminate tail-end to a SAE-AS25274 cap.

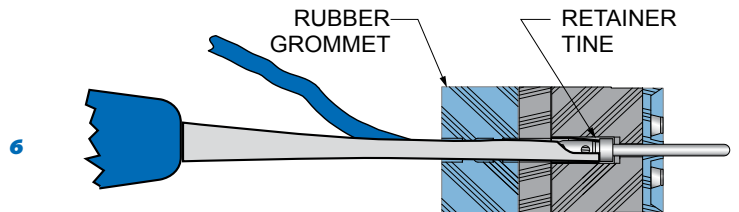
Contact Size	Wire Diameters (Inches)*	
	Min	Max
10	0.135	0.016
12	0.097	0.142
16	0.065	0.109
20	0.040	0.077
22	0.034	0.060
22M, 22D	0.030	0.060



CONTACT RETAINER CLIP

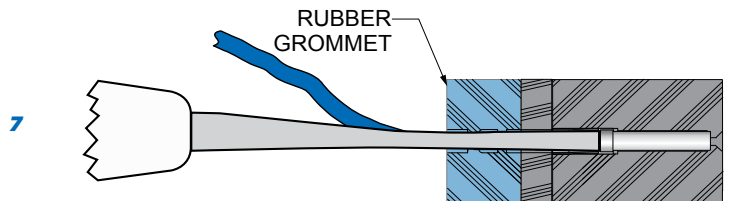
\*The min diameters are to ensure proper sealing. The max diameters are to allow the use of removal tools.

Contact Size	Seal Plug	Cap
10	AS84049/81-10	AS25474-4
12	MS27488-12	AS25474-4
16	MS27488-16	AS25474-3
20	MS27488-20	AS25474-2
22, 22M, 22D	MS27488-22	N/A



6

**7 Contact Extraction.** Use the white end of appropriate insertion/extraction tool. First, push the wire into the groove of the extraction tool's tip. Slide the tip of the tool over the jacketed wire into the connector cavity. Push the tool until the tip bottoms in the connector. A straight push is best. Avoid wiggling or rocking the tip, as this may damage the cavity. Pinch the wire between your thumb and the white plastic grip and slide the tool and contact out of the connector.



7

### Crimp Tool And Positioner For #12 and #16 Power Contacts



**1** Crimp tool for use with size #16 and #12 power pins. 9.75 inches OAL, 1.25 pounds. Use with M39029/57 and /58 contacts and 809-093 adapters.

**2** Positioner for use with size #12 and #16 Power contacts.

Figure	Military Part Number	Daniels Part Number	Tool Code
1	M22520/1-01	AF8	A
2	M22520/1-04	TH163	B

### Miniature Adjustable Crimp Tool for #12, #16, #20, #22D Signal Contacts

These crimp tools perform precision eight indent crimps for gas-tight wire terminations and excellent tensile strength. Adjustment wheel has 8 settings. Ratchet mechanism prevents improper crimps. Use with bayonet-type positioners. Check calibration with M22520/3 gages. Length is 6.75 inches, weight is approx. 10 oz.



**1** Standard M22520/2-01 miniature crimper. Use with standard size #20 and #22D contacts and with M39029/76, /77 and /78 coaxial center contacts. Requires positioner, ordered separately.

Glenair Part Number	Military Part Number	Daniels Part Number	Tool Code
<b>809-015</b>	M22520/2-01	AFM8	C

**2** Positioner for M39029/76, 77 and 78 coaxial inner contact. Use with 809-015 crimp tool.



Coax/Power	Contact Size	Military Part Number	Daniels Part Number	Notes	Tool Code
Power	#20	M22520/2-10	K43	Series I, II, III and IV	D
Power	#22D	M22520/2-09	K42	Series I, II, III and IV Pin	E
Power	#22D	M22520/2-07	K40	Series I, III and IV Socket	F
Power	#22D	M22520/2-06	K41	Series II Socket	G
Coax	#16	M22520/2-35	K532-1	Series I, II, III and IV	H
Coax	#12	M22520/2-34	K323	Series I, II, III and IV	I
Quadrax	#24	M22520/2-37	K709	Quadrax Inner Contact	J

## Parallel Action Crimp Tool and Hex Die Set



**1** Parallel action tool for use with hex crimp dies. 11 inches OAL, 2.0 pounds. Anodized aluminum frame, steel mechanism, plastic handles. Includes tool for die set removal. Accepts all M22520/5 die sets.

**2** Die set for terminating coaxial shield to outer contact. Use with size #12 matched impedance M39029/102 and 103 type coaxial contacts. Set consists of upper and lower halves. Made of hardened steel with black oxide finish. Approximately 2 inches in length, assembled. Die set has two closures per illustration.

Figure	Glenair Part Number	Military Part Number	Daniels Part Number	Tool Code
1	<b>809-129</b>	M22520/5-01	HX4	K
2	<b>809-130</b>	M22520/5-03	Y196	L
3	<b>859-007</b>	M22520/5-45	Y143	M

## Crimp Tool And Positioner For #12 Coaxial Outer Contact



For crimping size #12 shield sleeves. These mil spec approved tools feature a ratchet mechanism to prevent damage from overcrimping. Check calibration with M22520/3 gage.

**1** Crimp tool for use with size #12 coaxial contacts. Black handles. 9.75 inches OAL, 1.25 pounds.

**2** Positioner for use with size #12 coaxial contacts. Use with 809-133 (M22520/31-01) crimp tool.

Figure	Glenair Part Number	Military Part Number	Daniels Part Number	Tool Code
1	<b>809-133</b>	M22520/31-01	GS200-1	N
2	<b>809-134</b>	M22520/31-02	G2P330	P

## Crimp Tool And Positioner For #16 Coaxial Outer Contact

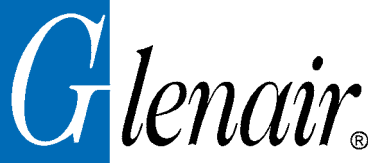


For crimping size #16 shield sleeves. These mil spec approved tools feature a ratchet mechanism to prevent damage from overcrimping. Check calibration with M22520/3 gage.

**1** Crimp tool for use with size #16 coaxial contacts. Blue handles. 9.75 inches OAL, 1.25 pounds.

**2** Positioner for use with size #16 coaxial contacts. Use with 809-127 (M22520/4-01) crimp tool.

Figure	Glenair Part Number	Military Part Number	Daniels Part Number	Tool Code
1	<b>809-127</b>	M22520/4-01	GS100-1	Q
2	<b>809-126</b>	M22520/4-02	GP295	R



## MIL-DTL-38999 Series III Pin Contact Selection Guide

AS39029 Pin Contacts										
38999 Series III Type	Contact Size	Type	Glenair Part Number	Military Part Number	Color Bands			BIN	Wire Size	Tool Code
					1st	2nd	3rd			
F	#10	S	850-002-10-528	M39029/58-528	GREEN	RED	GREY	528	#10 - #12	Consult Factory
		E	850-007-10-624	M39029/107-624	BLUE	RED	YELLOW	624		
	#12	S	850-002-12-365	M39029/58-365	ORANGE	BLUE	GREEN	365	#12 - #14	A, B
		E	850-007-12-623	M39029/107-623	BLUE	RED	ORANGE	623		
		C	852-002-12-211	M39029/28-211	RED	BROWN	BROWN	211	RG174 RG179 RG316	C, I (inner)
		C	852-002-12-409	M39029/28-409	YELLOW	BLACK	WHITE	409	RG180	N, P (outer)
	#16	S	850-002-16-364	M39029/58-364	ORANGE	BLUE	YELLOW	364	#16 - #20	A, B
		E	850-007-16-622	M39029/58-622	BLUE	RED	RED	622		
		C	852-008-16-424	M39029/76-424	YELLOW	RED	YELLOW	424	RG174 RG179 RG316	C, H (inner)
		C	852-008-16-425	M39029/76-425	YELLOW	RED	GREEN	425	RG178	Q, R (outer)
	#20	S	850-002-20-363	M39029/58-363	ORANGE	BLUE	ORANGE	363	#20 - #24	C, D
		E	850-007-20-621	M39029/107-621	BLUE	RED	BROWN	621		
#22D	S	850-002-22-360	M39029/58-360	ORANGE	BLUE	BLACK	360	#22 - #28	C, E	
	E	850-007-22-620	M39029/107-620	BLUE	RED	black	620			

Type	Crimp Style
S	Standard-Duty Crimp
E	Extended-Duty Crimp
C	Coaxial Crimp

BIN Color Coding									
0	1	2	3	4	5	6	7	8	9
BLACK	BROWN	RED	ORANGE	YELLOW	GREEN	BLUE	VIOLET	GREY	WHITE



# MIL-DTL-38999 Series III Socket Contact Selection Guide



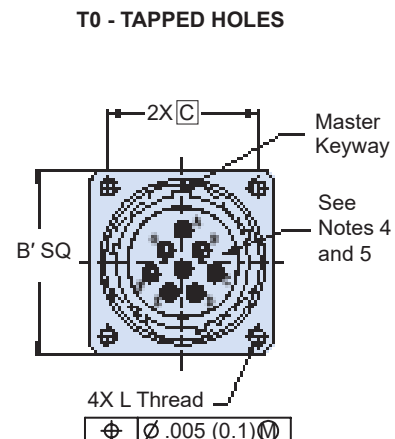
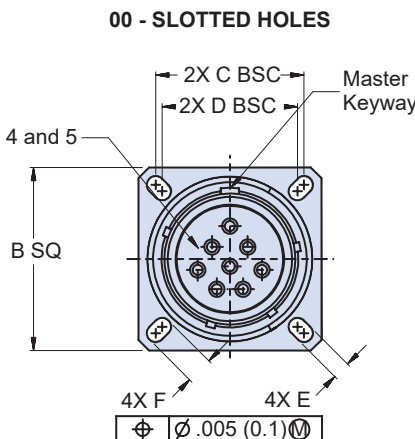
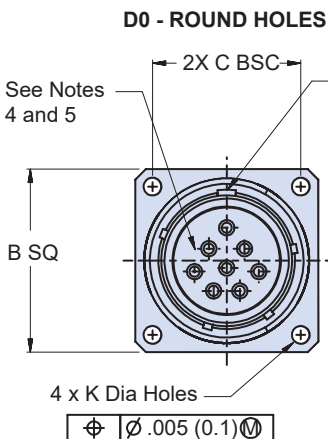
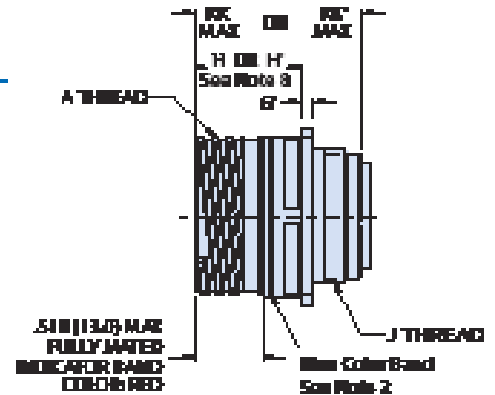
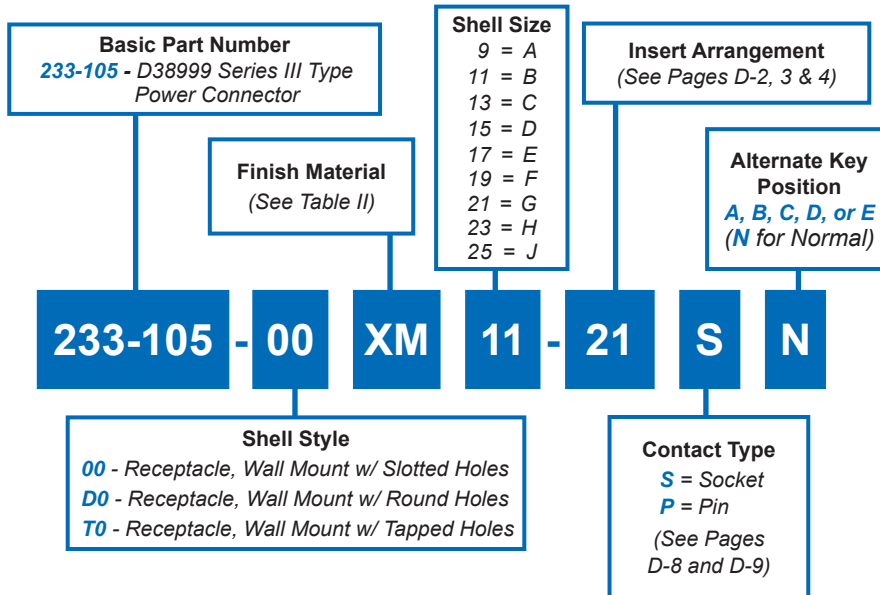
AS39029 Socket Contacts										
Contact Size	Type	Glenair Part Number	Military Part Number	Color Bands			BIN	Wire Size	Tool Code	
				1st	2nd	3rd				
#10	S	850-001-10-527	M39029/56-527	GREEN	RED	VIOLET	527	#10 - #12	Consult Factory	
	E	850-006-10-618	M39029/106-618	BLUE	BROWN	GREY	618			
#12	S	850-001-12-353	M39029/56-353	ORANGE	GREEN	ORANGE	353	#12 - #14	A, B	
	E	850-006-12-617	M39029/106-617	BLUE	BROWN	VIOLET	617			
	C	852-003-12-416	M39029/75-416	YELLOW	BROWN	BLUE	416	RG174 RG179 RG316	C, I (inner)	
	C	852-003-12-417	M39029/75-417	YELLOW	BROWN	VIOLET	417	RG180	N, P (outer)	
#16	S	850-001-16-352	M39029/56-352	ORANGE	GREEN	RED	352	#16 - #20	A, B	
	E	850-006-16-616	M39029/106-616	BLUE	BROWN	BLUE	616			
	C	852-009-16-428	M39029/77-428	YELLOW	RED	GREY	428	RG174 RG179 RG316	C, H (inner)	
	C	852-009-16-429	M39029/77-429	YELLOW	RED	WHITE	429	RG178	Q, R (outer)	
#20	S	850-001-20-351	M39029/56-351	ORANGE	GREEN	BROWN	351	#20 - #24	C, D	
	E	850-006-20-615	M39029/106-615	BLUE	BROWN	GREEN	615			
#22D	S	850-001-22-348	M39029/56-348	ORANGE	YELLOW	GREY	348	#22 - #28	C, F	
	E	850-006-22-614	M39029/106-614	BLUE	BROWN	YELLOW	614			

Type	Crimp Style
S	Standard-Duty Crimp
E	Extended-Duty Crimp
C	Coaxial Crimp

BIN Color Coding									
0	1	2	3	4	5	6	7	8	9
BLACK	BROWN	RED	ORANGE	YELLOW	GREEN	BLUE	VIOLET	GREY	WHITE



**233-105-00**  
**MIL-DTL-38999 Series III Type**  
**Wall Mount Environmental Receptacle Connector**



Consult factory for available insert arrangements.

**APPLICATION NOTES**

- Material/ Finishes:  
Shells, Jam Nut - See Table II  
(Composite Jam Nut & Composite Coupling Nut No Plating Required).  
Insulators- High Grade Rigid Dielectric/ N.A  
Seals- Fluorosilicone/ N.A.
- Blue Color Band indicates rear release retention system.
- Assembly to be identified with Glenair's name, part number and date code space permitting.
- Insert arrangement in accordance with MIL-STD-1560.
- Insert arrangement shown is for reference only.
- Metric dimensions (mm) are in parentheses.
- Composite connectors use dimensions G', H', and KK'.
- For shell style T0 only dimensions H and G' apply.

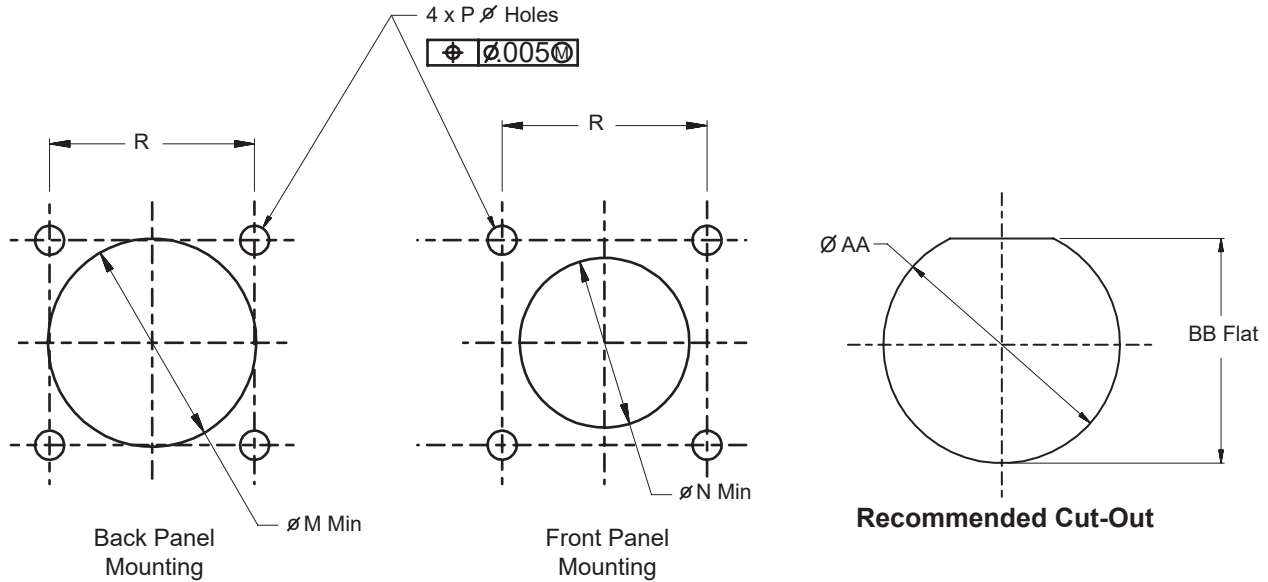
**TABLE II: FINISH**

SYM	MATERIAL	FINISH	MIL SYM
ME	Aluminum	Electroless Nickel	F
MA		Electroless Nickel	G
MT		Ni-PTFE (Nickel Fluorocarbon Polymer)	T
TZ		Tin-Zinc (SnZn) Over Electroless Nickel Over Suitable Underplate	V
NF		Cadmium Plate Olive Drab over Electroless Nickel	W
ZR		Zinc Nickel, Black Over Suitable Underplate	Z
MN		Tri-Nickel Alloy	AA
XW	Composite	Cadmium Olive Drab over Electroless Nickel	J
XM		Electroless Nickel	M
Z1	Stainless Steel	Passivate	K
ZL		Electrodeposited Nickel	S
AB	Marine Bronze	None (Clean Only)	-

**TABLE III: SHELL SIZE**

Shell Size Code	Shell Size	A Thread	B SQ	B' SQ	C BSC	D BSC	E	F	G	H	J Thread	K Holes Dia
A	9	.6250-.1P-.3L-TS-2A	.949 (24.1) .925 (23.5)	1.039 (26.39) .999 (25.37)	.719 (18.3)	.594 (15.1)	.136 (3.5) .120 (0.1)	.224 (5.7) .208 (5.3)	.144 (3.7) .083 (2.1)	.820 (20.8) .768 (19.5)	M12 x 1.0-6g 0.100R	.136 (3.5) .120 (3.0)
B	11	.7500-.1P-.3L-TS-2A	1.043 (26.5) 1.019 (25.9)	1.132 (28.75) 1.092 (27.74)	.812 (20.6)	.719 (18.3)	.136 (3.5) .120 (0.1)	.202 (5.1) .188 (4.7)	.144 (3.7) .083 (2.1)	.820 (20.8) .768 (19.5)	M15 x 1.0-6g 0.100R	.136 (3.5) .120 (3.0)
C	13	.8750-.1P-.3L-TS-2A	1.138 (28.9) 1.114 (28.3)	1.226 (31.14) 1.186 (30.12)	.906 (23.0)	.812 (20.6)	.136 (3.5) .120 (0.1)	.202 (5.1) .188 (4.7)	.144 (3.7) .083 (2.1)	.820 (20.8) .768 (19.5)	M18 x 1.0-6g 0.100R	.136 (3.5) .120 (3.0)
D	15	1.0000-.1P-.3L-TS-2A	1.232 (31.3) 1.208 (30.7)	1.289 (32.74) 1.249 (31.72)	.969 (24.6)	.906 (23.0)	.136 (3.5) .120 (0.1)	.202 (5.1) .208 (5.3)	.144 (3.7) .083 (2.1)	.820 (20.8) .768 (19.5)	M22 x 1.0-6g 0.100R	.136 (3.5) .120 (3.0)
E	17	1.1875-.1P-.3L-TS-2A	1.323 (33.6) 1.299 (33.0)	1.382 (35.10) 1.342 (34.09)	1.062 (27.0)	.969 (24.6)	.136 (3.5) .120 (0.1)	.202 (5.1) .188 (4.7)	.144 (3.7) .083 (2.1)	.820 (20.8) .768 (19.5)	M25 x 1.0-6g 0.100R	.136 (3.5) .120 (3.0)
F	19	1.2500-.1P-.3L-TS-2A	1.449 (36.8) 1.425 (36.2)	1.476 (37.49) 1.436 (36.47)	1.156 (29.4)	1.062 (27.0)	.136 (3.5) .120 (0.1)	.202 (5.1) .188 (4.7)	.144 (3.7) .083 (2.1)	.820 (20.8) .768 (19.5)	M28 x 1.0-6g 0.100R	.136 (3.5) .120 (3.0)
G	21	1.3750-.1P-.3L-TS-2A	1.575 (40.0) 1.551 (39.4)	1.582 (40.18) 1.542 (39.17)	1.250 (31.8)	1.156 (29.4)	.136 (3.5) .120 (0.1)	.202 (5.1) .188 (4.7)	.171 (65.2) .083 (39.8)	.790 (20.1) .736 (18.7)	M31 x 1.0-6g 0.100R	.136 (3.5) .120 (3.0)
H	23	1.5000-.1P-.3L-TS-2A	1.701 (43.2) 1.677 (42.6)	1.739 (44.17) 1.699 (43.15)	1.375 (34.9)	1.250 (31.8)	.162 (4.1) .146 (3.7)	.250 (6.4) .234 (5.9)	.171 (65.2) .083 (39.8)	.790 (20.1) .736 (18.7)	M34 x 1.0-6g 0.100R	.162 (4.1) .146 (3.7)
J	25	1.6250-.1P-.3L-TS-2A	1.823 (46.3) 1.799 (45.7)	1.884 (47.85) 1.824 (46.33)	1.500 (38.1)	1.375 (34.9)	.162 (4.1) .146 (3.7)	.250 (6.4) .234 (5.9)	.171 (65.2) .083 (39.8)	.790 (20.1) .736 (18.7)	M37 x 1.0-6g 0.100R	.162 (4.1) .146 (3.7)

**233-105-00**  
**MIL-DTL-38999 Series III Type**  
**Wall Mount Environmental Receptacle Connector**

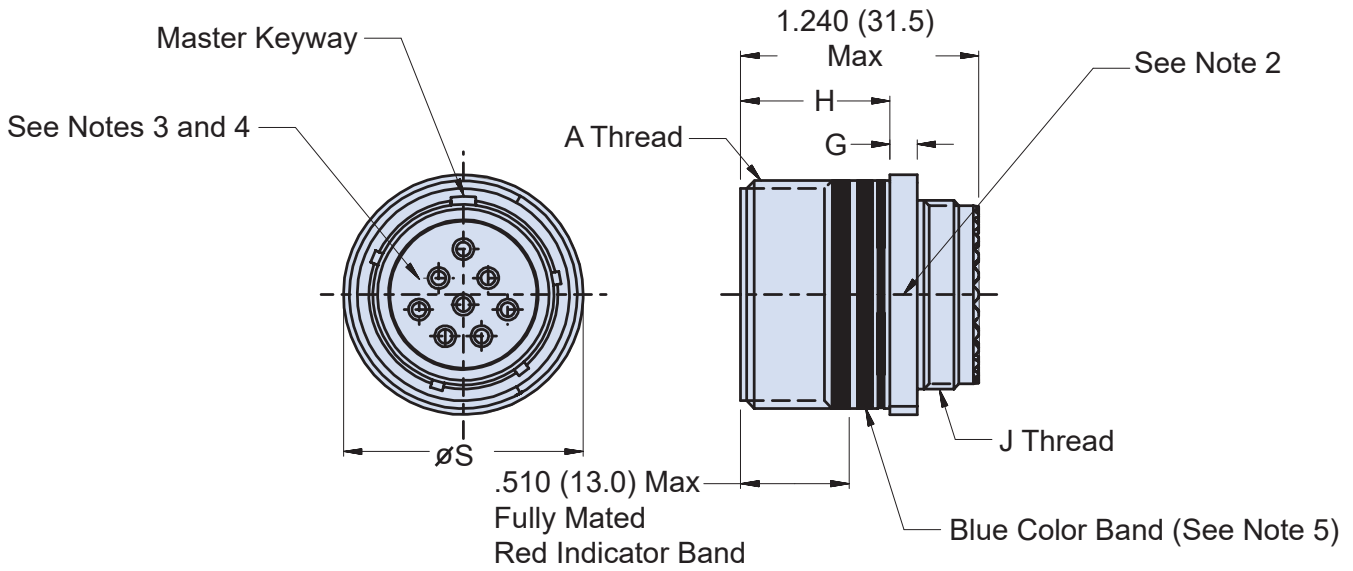
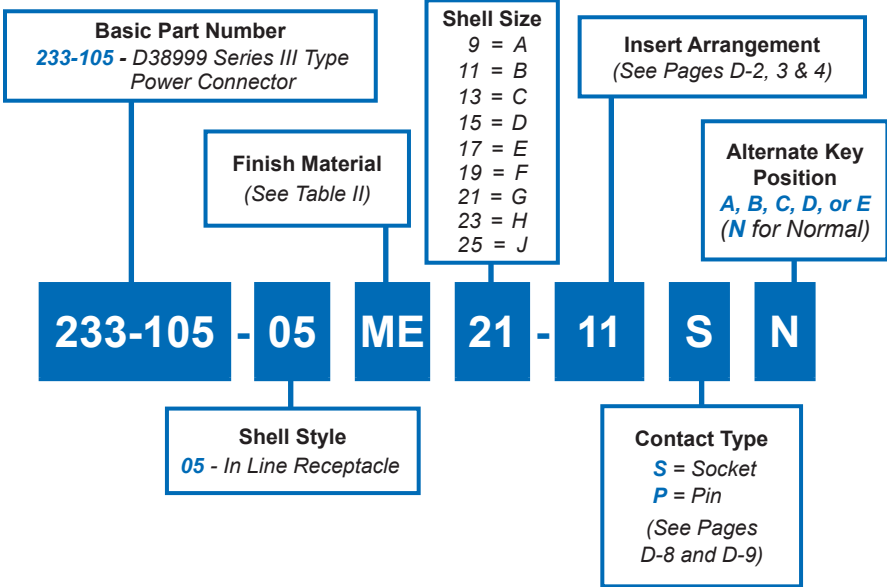


**Recommended Mounting Holes  
for Wall Mount Receptacle**

TABLE IV: SHELL SIZE							
Shell Size Code	Shell Size	AA Dia	BB Flat	M Ø Min	N Ø Min	P Ø Holes	R BSC
A	9	.703 (17.9)	.657 (16.7)	.656 (16.7)	.516 (13.1)	.133 (3.4)	.719 (18.3)
		.693 (17.6)	.655 (16.6)			.123 (3.1)	
B	11	.835 (21.2)	.771 (19.6)	.796 (20.2)	.625 (15.9)	.133 (3.4)	.812 (20.6)
		.825 (21.0)	.769 (19.5)			.123 (3.1)	
C	13	1.020 (25.9)	.955 (24.3)	.922 (23.4)	.750 (19.1)	.133 (3.4)	.906 (23.0)
		1.010 (25.7)	.943 (24.0)			.123 (3.1)	
D	15	1.145 (29.1)	1.085 (27.6)	1.047 (26.6)	.906 (23.0)	.133 (3.4)	.969 (24.6)
		1.135 (28.8)	1.083 (27.5)			.123 (3.1)	
E	17	1.270 (32.3)	1.210 (30.7)	1.219 (31.0)	1.016 (25.8)	.133 (3.4)	1.062 (27.0)
		1.260 (32.0)	1.208 (30.7)			.123 (3.1)	
F	19	1.395 (35.4)	1.335 (33.9)	1.297 (32.9)	1.141 (29.0)	.133 (3.4)	1.156 (29.4)
		1.385 (35.2)	1.333 (33.9)			.123 (3.1)	
G	21	1.520 (38.6)	1.460 (37.1)	1.422 (36.1)	1.266 (32.2)	.133 (3.4)	1.250 (31.8)
		1.510 (38.4)	1.458 (37.0)			.123 (3.1)	
H	23	1.645 (41.8)	1.585 (40.3)	1.547 (39.3)	1.375 (34.9)	.159 (4.0)	1.375 (34.9)
		1.635 (41.5)	1.583 (40.2)			.149 (3.8)	
J	25	1.770 (45.0)	1.710 (43.4)	1.672 (42.5)	1.484 (37.7)	.155 (3.9)	1.500 (38.1)
		1.760 (44.7)	1.708 (43.4)			.145 (3.7)	

Metric dimensions (mm) are indicated in parentheses

**233-105-05**  
**MIL-DTL-38999 Series III Type**  
**In-Line Environmental Receptacle Connector**



Consult factory for available insert arrangements.

**APPLICATION NOTES**

- |   |   |
|---|---|
| <p>1. Material/ Finishes:<br/>         Shells - See Table II<br/>         Insulator- High Grade Rigid Dielectric/ N.A<br/>         Seals- Fluorosilicone/ N.A.</p> <p>2. Assembly to be identified with Glenair's name, part number and date code space permitting.</p> | <p>3. Insert arrangement in accordance with MIL-STD-1560.</p> <p>4. Insert arrangement shown is for reference only.</p> <p>5. Blue Color Band indicates rear release retention system.</p> <p>7. Metric Dimensions (mm) are indicated in parentheses.</p> |
|---|---|

**233-105-05**  
**MIL-DTL-38999 Series III Type**  
**In-Line Environmental Receptacle Connector**

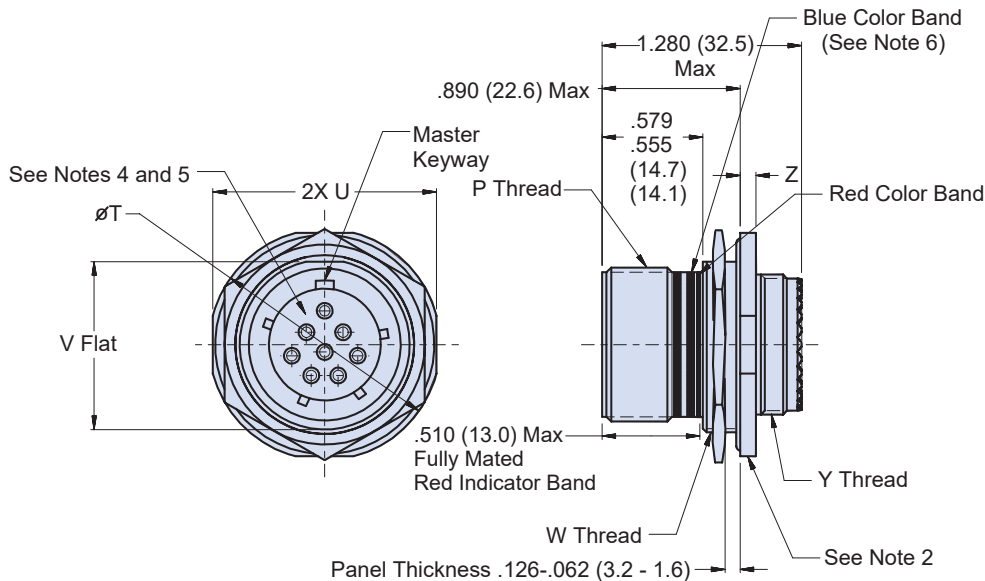
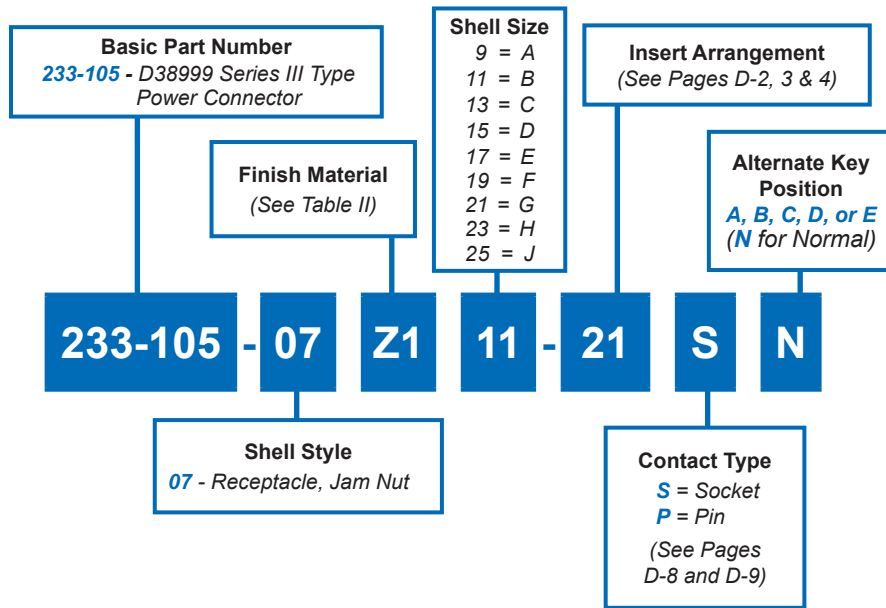


**TABLE II: FINISH**

SYM	MATERIAL	FINISH	MIL SYM
ME	Aluminum	Electroless Nickel	F
MA		Electroless Nickel	G
MT		Ni-PTFE (Nickel Fluorocarbon Polymer)	T
TZ		Tin-Zinc (SnZn) Over Electroless Nickel Over Suitable Underplate	V
NF		Cadmium Plate Olive Drab over Electroless Nickel	W
ZR		Zinc Nickel, Black Over Suitable Underplate	Z
MN		Tri-Nickel Alloy	AA
XW	Composite	Cadmium Olive Drab over Electroless Nickel	J
XM		Electroless Nickel	M
Z1	Stainless Steel	Passivate	K
ZL		Electrodeposited Nickel	S
AB	Marine Bronze	None (Clean Only)	-

**TABLE III: SHELL SIZE**

Shell Size Code	Shell Size	A Thread	G	H	S Max Dia	J Thread
A	09	.6250-.1P-.3L-TS-2A	.144 (3.7) .083 (2.1)	.823 (20.9) .768 (19.5)	.858 (21.8)	M12 x 1.0-6g 0.100R
B	11	.7500-.1P-.3L-TS-2A	.144 (3.7) .083 (2.1)	.823 (20.9) .768 (19.5)	.984 (25.0)	M15 x 1.0-6g 0.100R
C	13	.8750-.1P-.3L-TS-2A	.144 (3.7) .083 (2.1)	.823 (20.9) .768 (19.5)	1.157 (29.4)	M18 x 1.0-6g 0.100R
D	15	1.0000-.1P-.3L-TS-2A	.144 (3.7) .083 (2.1)	.823 (20.9) .768 (19.5)	1.280 (32.5)	M22 x 1.0-6g 0.100R
E	17	1.1875-.1P-.3L-TS-2A	.144 (3.7) .083 (2.1)	.823 (20.9) .768 (19.5)	1.406 (35.7)	M25 x 1.0-6g 0.100R
F	19	1.2500-.1P-.3L-TS-2A	.144 (3.7) .083 (2.1)	.823 (20.9) .768 (19.5)	1.516 (38.5)	M28 x 1.0-6g 0.100R
G	21	1.3750-.1P-.3L-TS-2A	.171 (65.2) .083 (39.8)	.791 (20.0) .736 (18.7)	1.642 (41.7)	M31 x 1.0-6g 0.100R
H	23	1.5000-.1P-.3L-TS-2A	.171 (65.2) .083 (39.8)	.791 (20.0) .736 (18.7)	1.768 (44.9)	M34 x 1.0-6g 0.100R
J	25	1.6250-.1P-.3L-TS-2A	.171 (65.2) .083 (39.8)	.791 (20.0) .736 (18.7)	1.890 (48.0)	M37 x 1.0-6g 0.100R



Consult factory for available insert arrangements.

**APPLICATION NOTES**

- |   |  |
|---|--|
| <p>1. Material/ Finishes:<br/>                 Shells, Jam Nut - See Table II<br/>                 (Composite Jam Nut No Plating Required).<br/>                 Insulators- High Grade Rigid Dielectric/ N.A<br/>                 Seals- Fluorosilicone/ N.A.</p> <p>2. Assembly to be identified with Glenair's name, part number and date code space permitting.</p> | <p>3. Modified major diameter 1.252-1.257 (31.80-31.95).</p> <p>4. Insert arrangement in accordance with MIL-STD-1560.</p> <p>5. Insert arrangement shown is for reference only.</p> <p>6. Blue Color Band indicates rear release retention system.</p> <p>7. Metric dimensions (mm) are in parentheses.</p> |
|---|--|

**233-105-07**  
**MIL-DTL-38999 Series III Type**  
**Jam Nut Environmental Receptacle Connector**



**TABLE II: FINISH**

SYM	MATERIAL	FINISH	MIL SYM
ME	Aluminum	Electroless Nickel	F
MA		Electroless Nickel	G
MT		Ni-PTFE (Nickel Fluorocarbon Polymer)	T
TZ		Tin-Zinc (SnZn) Over Electroless Nickel Over Suitable Underplate	V
NF		Cadmium Plate Olive Drab over Electroless Nickel	W
ZR		Zinc Nickel, Black Over Suitable Underplate	Z
MN		Tri-Nickel Alloy	AA
XW	Composite	Cadmium Olive Drab over Electroless Nickel	J
XM		Electroless Nickel	M
Z1	Stainless Steel	Passivate	K
ZL		Electrodeposited Nickel	S
AB	Marine Bronze	None (Clean Only)	-

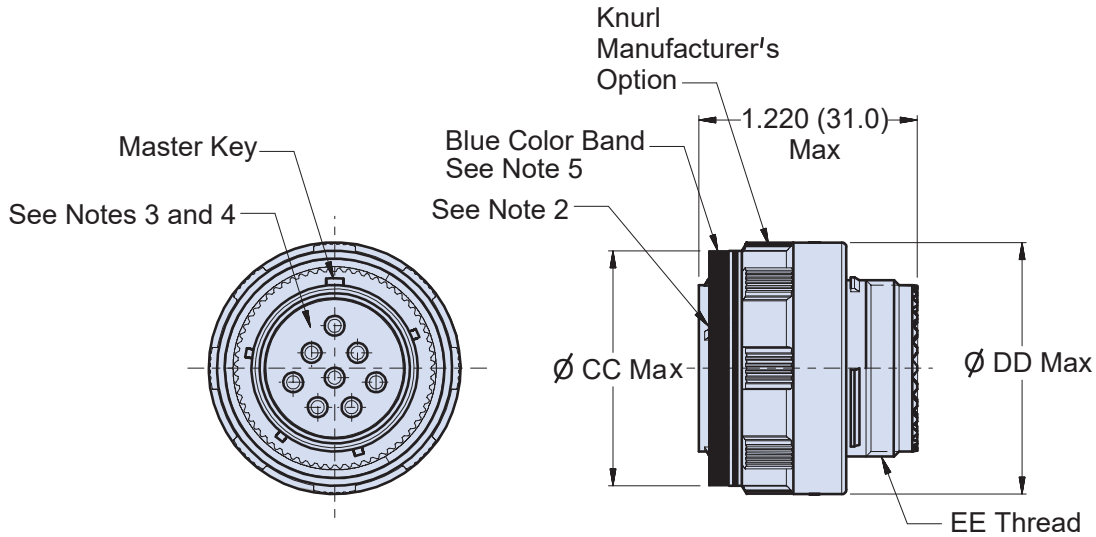
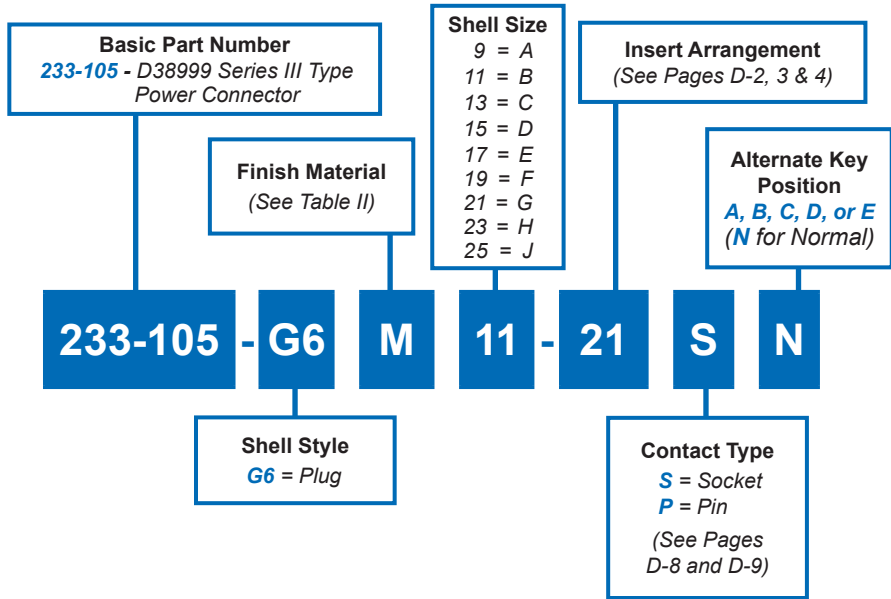
**TABLE III: SHELL SIZE**

Shell Size Code	Shell Size	P Thread	T Dia	U	V	W Thread	Y Thread	Z
A	09	.6250-.1P-.3L-TS-2A	1.200 (30.5) 1.178 (29.9)	1.078 (27.4) 1.048 (26.6)	.654 (16.6) .645 (16.4)	M17 x 1.0-6g 0.100R	M12 x 1.0-6g 0.100R	.122 (3.1) .083 (2.1)
B	11	.7500-.1P-.3L-TS-2A	1.386 (35.2) 1.362 (34.6)	1.268 (32.2) 1.236 (31.4)	.755 (19.2) .745 (18.9)	M20 x 1.0-6g 0.100R	M15 x 1.0-6g 0.100R	
C	13	.8750-.1P-.3L-TS-2A	1.512 (38.4) 1.488 (37.8)	1.390 (35.3) 1.358 (34.5)	.942 (23.9) .932 (23.7)	M25 x 1.0-6g 0.100R	M18 x 1.0-6g 0.100R	
D	15	1.0000-.1P-.3L-TS-2A	1.638 (41.6) 1.614 (41.0)	1.516 (38.5) 1.484 (37.7)	1.066 (27.1) 1.056 (26.8)	M28 x 1.0-6g 0.100R	M22 x 1.0-6g 0.100R	
E	17	1.1875-.1P-.3L-TS-2A	1.764 (44.8) 1.740 (44.2)	1.642 (41.7) 1.610 (40.9)	1.191 (30.3) 1.181 (30.0)	M32 x 1.0-6g 0.100R*	M25 x 1.0-6g 0.100R	
F	19	1.2500-.1P-.3L-TS-2A	1.949 (49.5) 1.925 (48.9)	1.827 (46.4) 1.795 (45.6)	1.316 (33.4) 1.306 (33.2)	M35 x 1.0-6g 0.100R	M28 x 1.0-6g 0.100R	.153 (3.9) .114 (2.9)
G	21	1.3750-.1P-.3L-TS-2A	2.075 (52.7) 2.051 (52.1)	1.953 (49.6) 1.921 (48.8)	1.441 (36.6) 1.431 (36.3)	M38 x 1.0-6g 0.100R	M31 x 1.0-6g 0.100R	
H	23	1.5000-.1P-.3L-TS-2A	2.201 (55.9) 2.177 (55.3)	2.079 (52.8) 2.047 (52.0)	1.566 (39.8) 1.556 (39.5)	M41 x 1.0-6g 0.100R	M34 x 1.0-6g 0.100R	
J	25	1.6250-.1P-.3L-TS-2A	2.323 (59.0) 2.299 (58.4)	2.205 (56.0) 2.173 (55.2)	1.691 (43.0) 1.681 (42.7)	M44 x 1.0-6g 0.100R	M37 x 1.0-6g 0.100R	

\*See Note 3



# 233-105-G6 MIL-DTL-38999 Series III Type Environmental Plug Connector



Consult factory for available insert arrangements.

### APPLICATION NOTES

1. Material/ Finishes:  
Barrel, Coupling Nut - See Table II  
(Composite Coupling Nut - No Plating Required).  
Insulators- High Grade Rigid Dielectric/ N.A  
Seals- Fluorosilicone/ N.A.
2. Assembly to be identified with Glenair's name, part number and date code space permitting.
3. Insert arrangement in accordance with MIL-STD-1560.
4. Insert arrangement shown is for reference only.
5. Blue Color Band indicates rear release retention system.
7. Metric Dimensions (mm) are indicated in parentheses.

**233-105-G6**  
**MIL-DTL-38999 Series III Type**  
**Environmental Plug Connector**



**TABLE II: FINISH**

SYM	MATERIAL	FINISH	MIL SYM
ME	Aluminum	Electroless Nickel	F
MA		Electroless Nickel	G
MT		Ni-PTFE (Nickel Fluorocarbon Polymer)	T
TZ		Tin-Zinc (SnZn) Over Electroless Nickel Over Suitable Underplate	V
NF		Cadmium Plate Olive Drab over Electroless Nickel	W
ZR		Zinc Nickel, Black Over Suitable Underplate	Z
MN		Tri-Nickel Alloy	AA
XW	Composite	Cadmium Olive Drab over Electroless Nickel	J
XM		Electroless Nickel	M
Z1	Stainless Steel	Passivate	K
ZL		Electrodeposited Nickel	S
AB	Marine Bronze	None (Clean Only)	-

D

**TABLE III: SHELL SIZE**

Shell Size Code	Shell Size	CC Max Dia	DD Max Dia	EE Thread
A	09	.811 (20.6)	.858 (21.8)	M12 x 1.0-6g 0.100R
B	11	.929 (23.6)	.984 (25.0)	M15 x 1.0-6g 0.100R
C	13	1.110 (28.2)	1.157 (29.4)	M18 x 1.0-6g 0.100R
D	15	1.232 (31.3)	1.280 (32.5)	M22 x 1.0-6g 0.100R
E	17	1.358 (34.5)	1.406 (35.7)	M25 x 1.0-6g 0.100R
F	19	1.469 (37.3)	1.516 (38.5)	M28 x 1.0-6g 0.100R
G	21	1.594 (40.5)	1.642 (41.7)	M31 x 1.0-6g 0.100R
H	23	1.720 (43.7)	1.768 (44.9)	M34 x 1.0-6g 0.100R
J	25	1.843 (46.8)	1.890 (48.0)	M37 x 1.0-6g 0.100R

# High Voltage Electrical Power Distribution



## From 0 to 60 in 3.9 Seconds

**H**igh voltage electrical power distribution is a critical component of the 100% electric Tesla Roadster.

The reliable distribution of electrical energy from the car's lithium-ion energy storage system to the vehicle's motor, electronic control module, HVAC system, transmission and regenerative braking unit depends on a high-performance wiring system made up of high-temperature

shielded conduit and ruggedized reverse-bayonet power connectors—all made by Glenair.

Glenair is on the forefront of innovative efforts to advance the reliability and performance of electric vehicles. Glenair power connectors, cables and conduit are deployed in high-voltage power management and distribution applications for systems as demanding as military vehicles—and as fast as the Tesla Roadster.



1211 Air Way · Glendale, California 91201-2497

Telephone: 818-247-6000 · Facsimile: 818-500-9912 · E-mail: [sales@glenair.com](mailto:sales@glenair.com)

United States · United Kingdom · Germany · Nordic · France · Italy · Spain · Japan

[www.glenair.com](http://www.glenair.com)

## One Stop Shopping for All Your Backshell, Connector and Cable Assembly Requirements

### ***Shield termination banding tools and connector-to-backshell assembly tools are just part of the story***

Glenair addresses interconnect system assembly requirements with a variety of military standard and specialized connector-to-backshell assembly tools, braided shielding banding tools and accessories. Our tool line for composite components includes connector wrenches, as well as universal connector holding tools for production use as well as field maintenance.

Glenair's connector and backshell holding tools and wrenches ensure fast and reliable

Glenair's Band-It® Termination System for braided metal and composite shielding includes both hand-held and bench-mounted units. The Band-It® Termination System provides fast and reliable shield terminations which pass the most stringent shock, vibration and thermal tests. The low-profile and smooth inside diameter of the one-piece austenitic stainless steel clamping band virtually eliminates RFI/EMI leakage paths.

*Backshell Assembly Tools*

*Banding Shield Termination Tools*

*Ergonomic Designs*

*Battlefield Tested Tools and Kits*

*Teflon Coated Jaws Prevent Damage*

*Individual Tools and Turnkey Kits*

*All Tools Quality Made in USA*



assembly of interconnect components to correct torque levels—a critical issue with all types of coupling systems. Special designs fit the unique knurling on composite connectors and backshells.

For more information on the complete range of tools supplied by Glenair, please see our *Interconnect Cable Assembly Tools* catalog, visit our website or consult the factory

## Glenair Assembly Tools Help Prevent Distortion and False Tightening Problems

*Composite backshell tightening tools are available and provide virtually a full 360° gripping surface on backshell coupling nuts. These innovative tools minimize the possibility of coupling nut distortion and false tightening problems often caused by soft-jaw pliers or strap wrenches.*

### Reliable Installation of Glenair Backshells on Circular Connectors

When used with the appropriate connector holders and torque wrenches, Glenair Backshell Assembly Tools provide the user with consistent, repeatable backshell installations. Designed primarily for production assembly use, the tools can also be used equally well for successful field maintenance operations.

Glenair Backshell Assembly Tools may also be utilized effectively with backshell rotatable couplers produced by other manufacturers, providing the "B" reference diameters are consistent with those shown within this catalog.

### Recommended Tightening Procedures

Recommended tightening procedures, tools and torque values offered by Glenair are intended as an aid to properly fasten the backshell to the connector interface threads.

Glenair offers a variety of tools to accomplish proper tightening; our 600-091 Hex Wrench is configured to make provide support to each

specific coupling nut to be tightened, our TG70 strap wrench is intended for general use on cable clamps. Hand-held and bench-mount torque wrenches accommodate our 600-005 plug or receptacle connector holders (see *Backshell Assembly Tool* catalog).

When tightening backshell onto connectors, it is important to follow Glenair's recommended procedures for each tool being used.

When tightening backshells with rotatable coupling nuts, Glenair recommends the backshell to be hand tightened to engage the connectors interlocking teeth or spline features, making sure the teeth are fully engaged before fully torquing with our tools. We also suggest retorquing by removing the tool and reinstalling the tool approximately 90° away from the initial position and tightening to the connector manufacturer's recommended value.

Composite backshells should be tightened to 80% of the values shown for AS85049 light and medium duty torque. Secondary components such as: Glenair's cable clamps, gland sealing nuts, sleeves or adapters, not directly fastened to the connector should be tightened 40 to 60 inch pounds to insure proper performance.

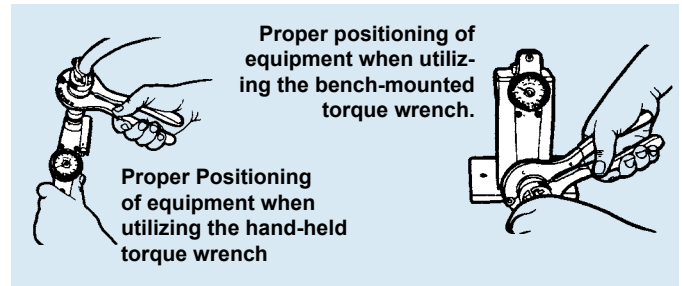
## Four Easy Steps for Proper Backshell Assembly

1. Select plug or receptacle holder (most holder series provide "universal polarization", but a few connector series require specific polarization for each alternate keying arrangement).
2. Set desired torque on torque wrench.
3. Mount holder on square drive of torque wrench. Carefully mate with connector, and hand-tighten Glenair backshell coupling. To assure proper mating, anti-rotation teeth must be fully engaged.
4. Tighten rotatable coupler with assembly tool. Do not use excessive grip on handles. When coupler begins to tighten, relax grip and rotate assembly tool back 90°, then resume grip and continue to tighten; repeating this sequence until desired torque level is reached.

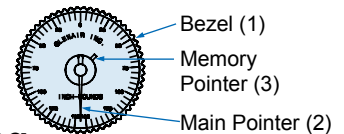
**CAUTION:** Do not apply torque in excess of signal setting. Excess torque will cause signal pointer to reset and give erroneous readings.

### Setting Torque Levels

To verify proper backshell installation values, electrical signals are built into bench-mounted (audio) and hand-held (light) torque wrenches. The procedure for setting torque levels is the same for both units.



### Setting Desired Torque for Right-Hand Thread Tightening



To set torque, turn Bezel (1) clockwise until signal is on. Continue to turn Bezel until Main Pointer (2) is at desired torque level on scale. You may cover the audio signal during this procedure to minimize noise level when setting the bench-mounted unit.

The Memory Pointer (3) is set by the above procedure. With this accomplished, turn Bezel counter-clockwise until the Main Pointer is aligned with zero on the scale. Your torque wrench is not ready for operation.

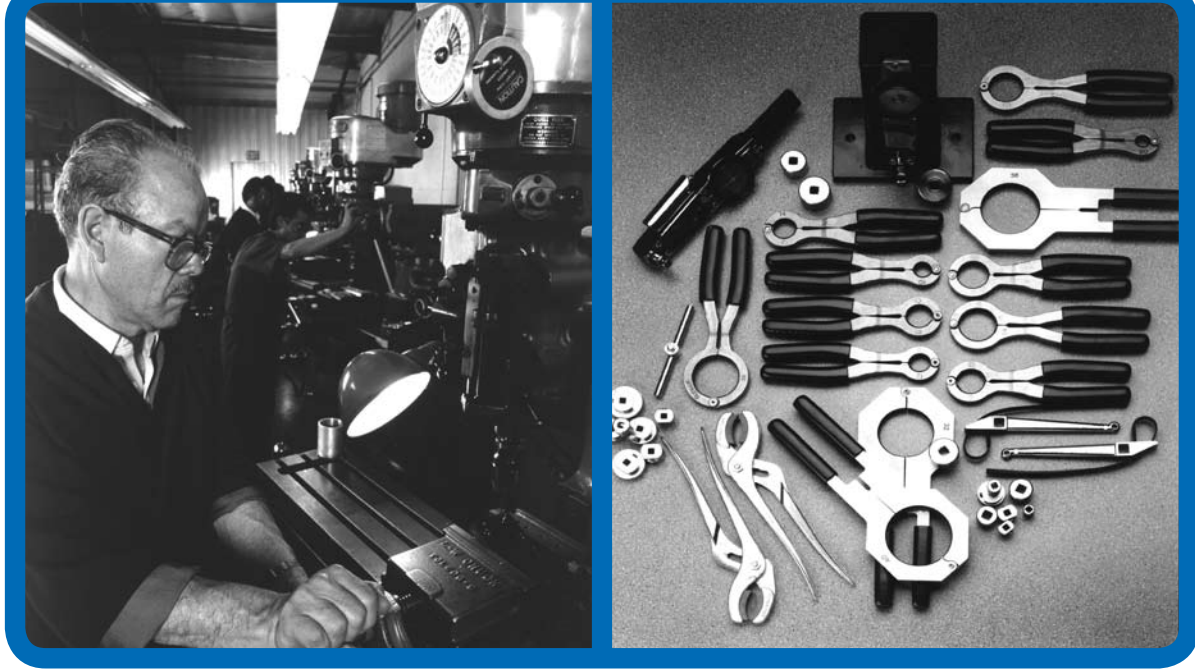
### Resetting the Memory Pointer

When you wish to change torque levels, rotate the Bezel counter-clockwise until the signal is on. Continue to rotate Bezel until Memory Pointer is aligned with zero on the scale. now repeat the above procedure for setting torque.

### Setting Desired Torque for Left-Handed Thread Tightening

Simply reverse the above procedure for setting the desired torque for left-hand thread tightening.

# Stop Toolin' Around



## Finding the right tool for the job just got a little bit easier

Nobody can grasp the ins-and-outs of interconnect tool design and manufacturing without a full understanding of cable harness assembly.

At Glenair, we not only manufacture the connectors, backshells, cables and enclosures which go into interconnect cable harnesses, we run a top-flight cable assembly service of our own. And we've drawn on this extensive experience to design and build

a complete family of specialized backshell assembly tools for most Mil-Standard circular connectors, as well as connector wrenches, mini-strap wrenches, universal connector holding tools and braid termination tools for production use and field maintenance.

Glenair is also now offering a broad range of fiber optic termination tools, including complete kits for both our Mil-T-29504 and front-release COTS termini.



1211 Air Way

Glendale, California 91201-2497

Telephone: 818-247-6000 · Facsimilie: 818-500-9912 · EMail: [sales@glenair.com](mailto:sales@glenair.com)

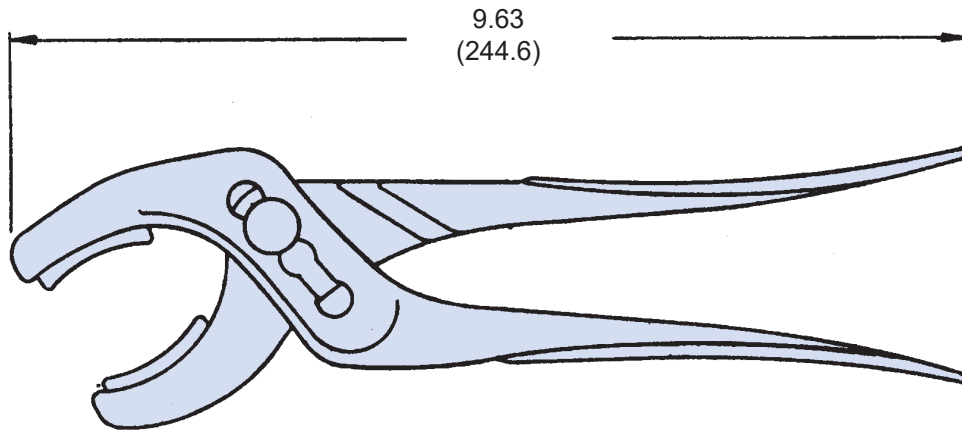
United States • United Kingdom • England • Nordic • France • Italy • Spain • Japan

[www.glenair.com](http://www.glenair.com)

## TG69 Soft Jaw Pliers

TG69

Basic  
Number



**NOTE:** Not recommended for composite coupling nuts (use 600-091 or 600-157)

### APPLICATION NOTES

1. Assembly identified per MIL-STD-130
2. Nylon replacement inserts: P/N G77015



**ALUMINUM TOOL FOR USE WITH GLENAIR COMPOSITE BACKSHELLS**

**600 - 091 - 16**

**Product Series**  
**Basic Number**  
**Dash Number for Individual Wrench or:**  
*K* - Kit of dash numbers 08 thru 28  
*KC* - "K" kit with case  
*KL* - Kit of dash number 32 thru 44  
*KLC* - "KL" kit with case  
*KIT* - Kit of dash numbers 08 thru 44 with case

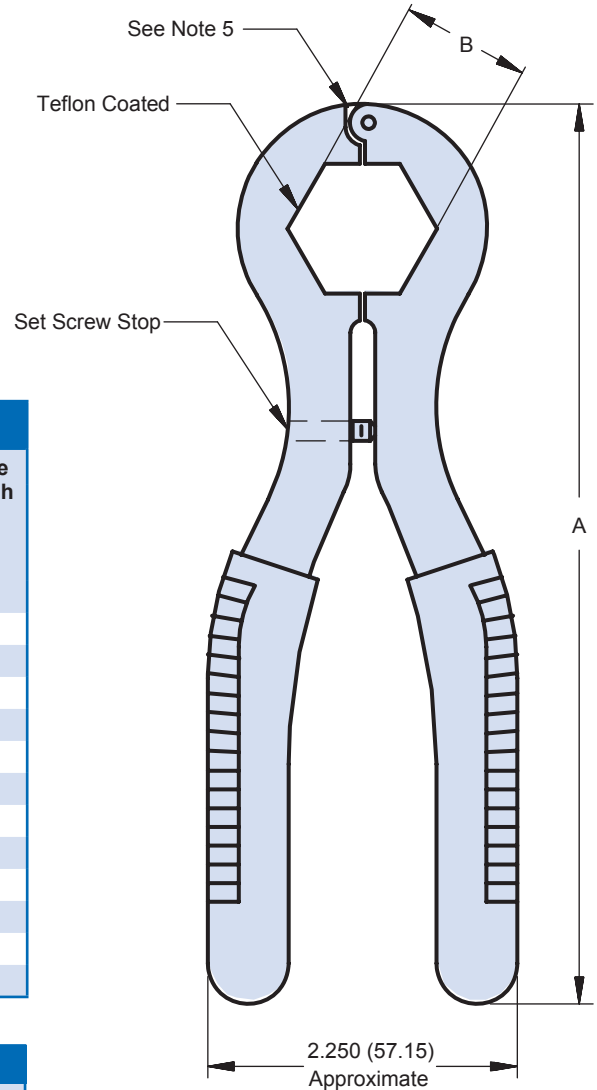
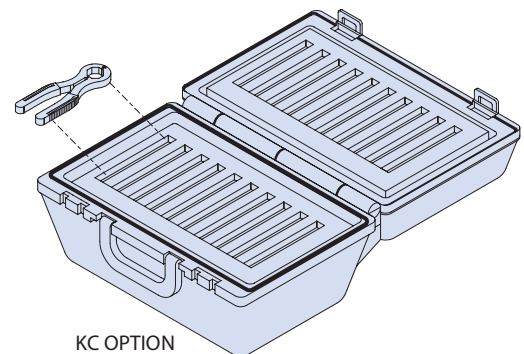


TABLE I: DASH NUMBER					
Dash Number	A Ref	B Hex <sup>2</sup> Ref	Connector for Shell Size		Composite Torque Inch Pounds In-Lbs Min/Max
			Codes A & F	Code H	
08	7.56 (192.0)	.750 (19.1)	08	09	20/25
10	7.56 (192.0)	.875 (22.2)	10	11	20/30
12	7.56 (192.0)	1.000 (25.4)	12	13	25/35
14	7.56 (192.0)	1.125 (28.6)	14	15	25/35
16	7.56 (192.0)	1.250 (31.8)	16	17	30/40
18	7.56 (192.0)	1.375 (34.9)	18	19	30/40
20	8.50 (215.9)	1.500 (38.1)	20	21	35/45
22	8.50 (215.9)	1.625 (41.3)	22	23	35/45
24	8.50 (215.9)	1.750 (44.5)	24	25	35/45
28	9.50 (241.3)	2.000 (50.8)	28		115/125
32	10.00 (254.0)	2.250 (57.2)	32		115/125
36	10.00 (254.0)	2.500 (63.5)	36		112/125
44	10.00 (254.0)	3.000 (76.2)	44		N/A

**APPLICATION NOTES**

- Use in conjunction with Glenair 600-161 torque wrench and 600-162B or 600-162BV bench mounts (see page 14).
- Adjust set screw per tool setting procedure GAP134 (available on Glenair.com). Once adjusted must fit Glenair hex composite coupling nuts
- Customer is responsible for maintaining adjustment to compensate for wear.
- Replace tool if excessive wear is observed
- Gap is permissible during tool use for coupling nut assembly
- If set screw becomes loose causing loss of adjustment reapply suitable thread locking compound
- Wrenches are made of aluminum alloy with vinyl grips.
- Using other manufacturer's hex wrench pliers or soft jaw coated pliers will result in premature fracturing or damage to the composite product



**KC OPTION**  
Approximate Case Dimensions: 13.5 x 15.5 x 3.875

# 600-157 Composite Connector Accessory Coupling Nut Wrench



## STAINLESS STEEL TOOL FOR USE WITH GLENAIR COMPOSITE BACKSHELLS

600

Product Series

- 157 -

Basic Number

K

Dash Number for Individual Wrench or:

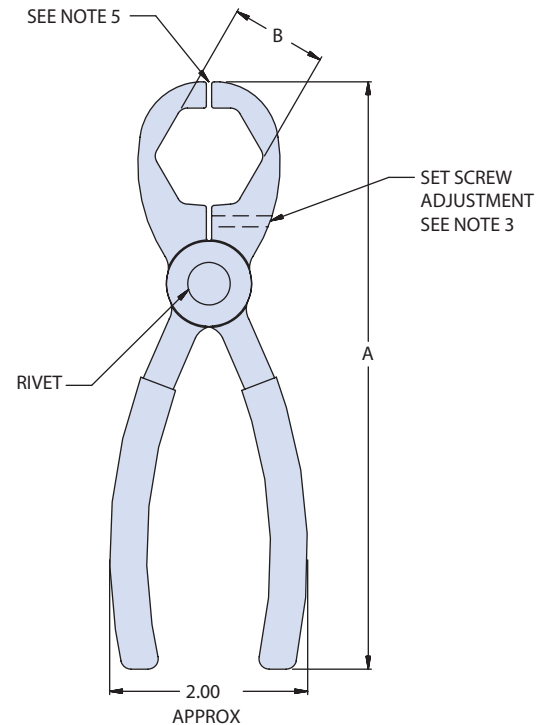
**K** - Kit of dash numbers 08 thru 28, no case

**KC** - "K" kit with case

**KL** - Kit of dash numbers 32 thru 44, no case

**KLC** = "KL" kit with case

**KIT** = Kit of dash numbers 08 thru 44 with case

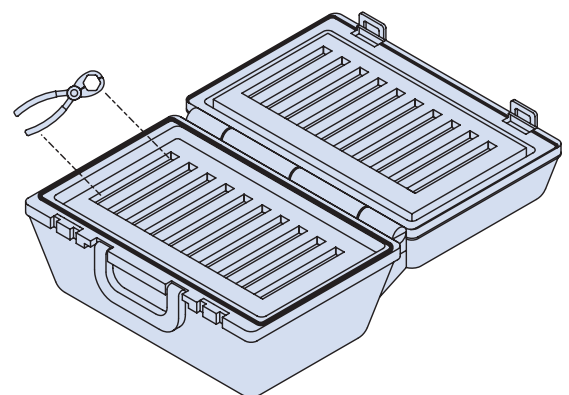


**TABLE I: DASH NUMBER**

Dash No.	A Ref	B Hex <sup>2</sup> Ref	Connector for Shell Size Codes		Composite Torque Inch Pounds In-Lbs Min/Max
			A & F	Code H	
08	6.70 (170.2)	.750 (19.1)	08	09	20/25
10	6.75 (171.5)	.875 (22.2)	10	11	20/30
12	6.81 (173.0)	1.000 (25.4)	12	13	25/35
14	6.88 (174.8)	1.125 (28.6)	14	15	25/35
16	6.95 (176.5)	1.250 (31.8)	16	17	30/40
18	7.05 (179.1)	1.375 (34.9)	18	19	30/40
20	7.15 (181.6)	1.500 (38.1)	20	21	35/45
22	7.38 (187.5)	1.625 (41.3)	22	23	35/45
24	7.44 (189.0)	1.750 (44.5)	24	25	35/45

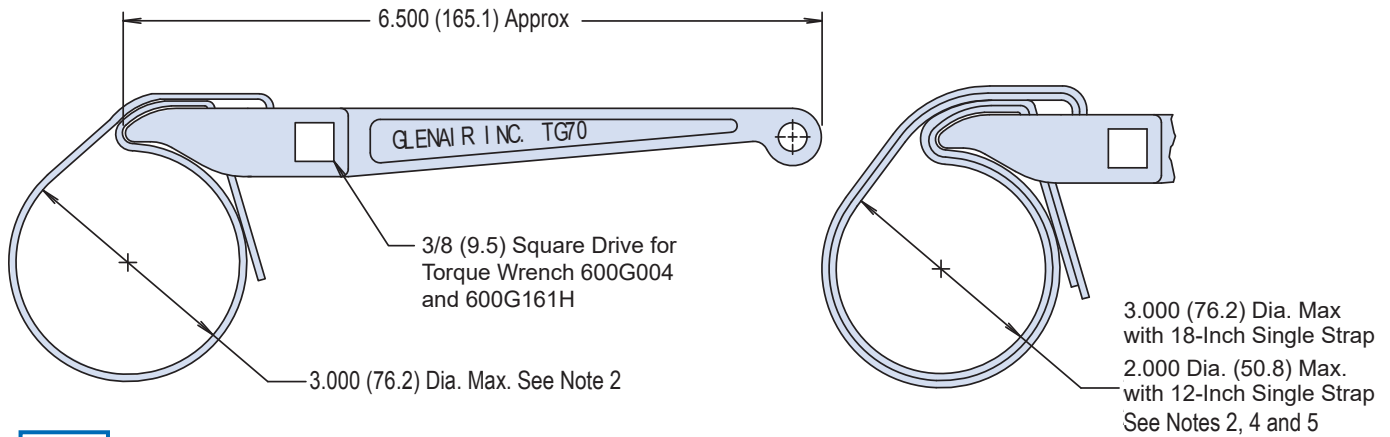
### APPLICATION NOTES

- Use in conjunction with Glenair 600-161 torque wrench and 600-162B or 600-162BV bench mounts (see page 14).
- Adjust set screw per tool setting procedure GAP134 (available on Glenair.com). Once adjusted must fit Glenair hex composite coupling nuts
- Dash Number 08, 10, 12 only. Customer is responsible for maintaining adjustment to compensate for wear.
- Replace tool if excessive wear is observed
- Gap is permissible during tool use for coupling nut assembly
- If set screw becomes loose causing loss of adjustment reapply suitable thread locking compound
- Wrenches are made of passivated SST with vinyl grips.
- Using other manufacturer's hex wrench pliers or soft jaw coated pliers will result in premature fracturing or damage to the composite product



KC Option  
Approximate Case Dimensions: 13.5 x 15.5 x 3.875

## TG70 Strap Wrench



**Basic Part Number**  
**Torque Wrench**  
(Omit for None)

**TG70 - 1 - 18**

**Strap Length in Inches (See Notes 2 and 4)**  
Lengths Available: 12, 18, 24 and 36-Inch Only  
Standard length is 12 Inches,  
Omit Dash Number for Standard

### APPLICATION NOTES

- These wrenches are made of the following materials:  
Wrench Handle - Aluminum Alloy/Nickel Plate.  
Wedge - Stainless Steel/Passivated.  
Strap - Impregnated Fabric. Straps are 1/2 inch (12.7) in width.
- Replacement straps are available. Specify part number G70515-xx for 12, 18, 24 or 36-inch strap. 24 and 36 inch for double wrap.
- Metric dimensions (mm) are indicated in parentheses.
- Double wrap as shown for heavy duty range.
- Not recommended for composite coupling nuts (use 600-091 or 600-157).

### INSTALLATION TORQUE VALUES FOR CIRCULAR ELECTRICAL CONNECTOR ACCESSORIES

Shell Sizes	Column 1 Light and Medium Duty	Column 2 Heavy Duty
	In-Lbs, Min/Max	In-Lbs, Min/Max
8, 9, A	30/40	51/61
3, 10, 10SL, 11, B	30/40	71/81
7, 12, 12S, 13, C	35/45	103/113
14, 14S, 15, D	35/45	111/121
16, 16S, 17, E	35/45	111/121
18, 19, 27, F	35/45	111/121
20, 21, 37, G	75/85	131/141
22, 23, H	75/85	131/141
24, 25, 61, J	75/85	131/141
28, 29	115/125	143/153
32, 33	115/125	143/153
36	115/125	142/153

### VARIANCE CHART NOTES

- Torque values per SAE AIR6151, all values are provided in Inch/Pounds.
- For additional guidance or values/conditions not listed, refer to the complete SAE AIR6151.
- Heavy duty installation torque values (Column 2) may be difficult to obtain using the standard single wrap strap as supplied in the TG70. To achieve column 2 torque across all shell sizes a double wrap strap (using longer straps) is required as well as very careful placement of the tool and strap around the coupling to achieve maximum grip. Clean and oil-free surfaces are imperative.
- Glenair 600-006/079/103/107 circular pliers are also suitable for higher torque ranges.
- Glenair recommends that torque values be measured directly read through the connector shell using suitable holding tool from our 600-005 sockets and ply holder with the use of 600-005 connectors holding tools.
- Due to the offset of the 3/8" square drive from the centerline of the applied torque (centerline of the connector/backshell) offset torque values must be calculated by using any of the common offset value formulas or web apps that are readily available.

# 600G161 Digital Torque Wrench and 600-162B Bench Stand



## DIGITAL TORQUE WRENCH AND BENCH STAND

### Torque Wrench 600G161



### Digital Readout For Improved Accuracy

The Glenair dual drive digital torque wrench (600G161-D) features a dual sided drive head for hand or bench mount use. Features rotatable digital readout display. Available torque units include: Ft-lb, In-lb and Nm. Peak and track modes allow for data collection capability via supplied software and USB adapter. Provides quality departments the ability to track and record individual torque values.

600-161-D data/charger kit. Upgrades 600G161 for data collection and battery recharging.

1. Use in conjunction with Glenair connector and backshell tools
2. Torque range: 25-250 in/lbs; digital graduations 1/10 in/lb;
3. Accuracy:  $\pm 1\%$  of indicated value
4. replacement battery: AAA x 4
5. USB cable, datatracking software, AC adapter, and 3/8" to 1/4" drive adapter included. Standard AAA alkaline batteries included with 600G161. Rechargeable NiMH AAA batteries and data/charger kit included with 600G161-D

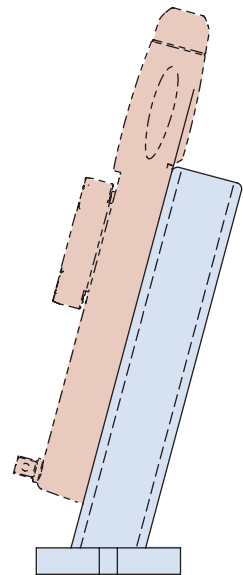
### 600-162B DIGITAL TORQUE WRENCH BENCH STAND

1. Use in conjunction with Glenair 600G161 or 600G161-D digital torque wrench, sold separately
2. Material: steel, powder coat
3. Weight: 3 lbs
4. Supplied with mounting hardware
5. Tools required: T15 Torx® bit, 3/32" hex key



### 600-162BV DIGITAL TORQUE WRENCH VERTICAL BENCH STAND

1. Use in conjunction with Glenair 600G161 or 600G161-D digital torque wrench, sold separately
2. Material: steel, powder coat
3. Weight: 3 lbs
4. Supplied with mounting hardware
5. Tools required: T15 Torx® bit, 3/32" hex key



600-164

**Large Broad Blade Utility Shear**  
for Cutting Metal-Clad Composite Braided Shielding  
Also Cuts Rubber, Cable Jacketing, Cable, Plastics and Rope

600 - 164

Product  
SeriesBasic  
Number

- Nickel Chrome Plating Resists Corrosion and Rusting
- Broad, Short Jaws Provide Powerful Cutting Action
- Extended Handle Provides Comfort and Cutting Leverage
- High Leverage Provides Powerful Cutting Action for Light Metals, Rubber and Heavy Fabrics
- Cuts Rubber, Cables, Light Metal, Wire Metal Screens and Braided EMI/EMP Shielding, Cordage, Plastics and Rope
- Weight: 0.55 Pounds
- Shear Cut Length: 2.000 (51.0)

#### Recommended EMI Braid Cutting Procedure



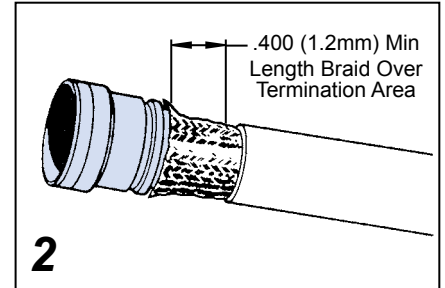
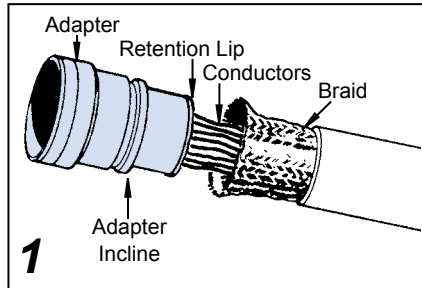
**Note:** When cutting braid, both metal and especially composite, open cutter blades to allow the full 2" cut. Place braid all the way back onto blades as shown.

#### APPLICATION NOTES

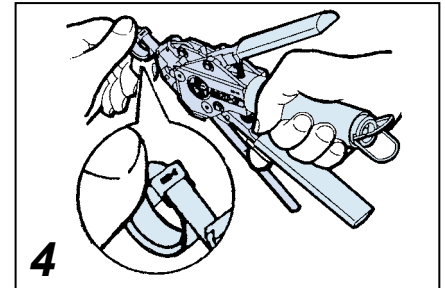
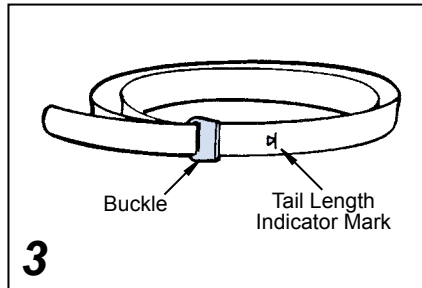
1. Metric dimensions (mm) are indicated in parentheses.
2. Always wear approved eye protection.
3. Never use on or near live electrical circuits.

## Shield Termination Assembly Process

1. Prepare Cable Braid for termination process (Figure 1).
2. Push Braid forward over Adapter Retention Lip to the Adapter Incline Point (or .4" [10.2mm] minimum braid length). Milk Braid as required to remove slack and insure a snug fit around the shield termination area (Figure 2).
3. Prepare the Band in the following manner:
  - IMPORTANT:** Due to Connector/Adapter circumference, it may be necessary to prepare the Band around the Cable or Retention Area.



- A. Roll Band through the Buckle Slot twice. (Bands must be double-coiled.)
- B. Pull on Band until Mark (▷) is within approximately .250 inch (6.4mm) of Buckle Slot (Figure 3). The Band may be tightened further if desired.

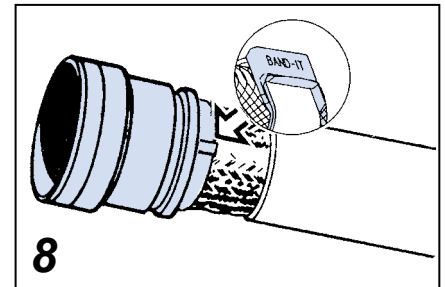
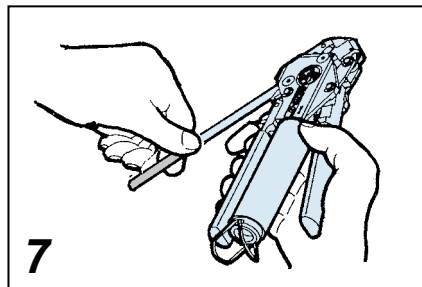
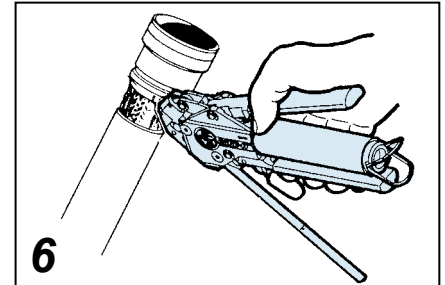
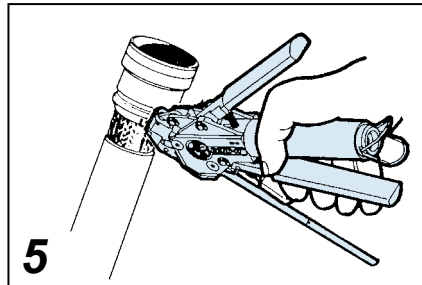


**NOTE:** Prepared Band should have (▷) Mark visible approximately where shown in Figure 3.

### Shield Termination Clamping Process (Figures 4 thru 8)

**NOTE:** To free Tool Handles, move Holding Clips to center of Tool.

4. Squeeze Gripper Release Lever and insert Band into the front end opening of the Tool. (NOTE: Circular portion of looped band must always face downward.)
5. Aligning the Band and Tool with the Shield Termination Area, squeeze Black Pull-Up Handle repeatedly using short strokes until it locks against Tool Body. (This indicates the Band is compressed to the Tool Precalibrated Tension.)
  - NOTE:** If alignment of band and shield is unsatisfactory, tension on band can be relaxed by pushing on slotted release lever on top of tool. Make adjustments as necessary and again squeeze black pull-up handle.
6. Complete the Clamping Process by squeezing the Gray Cut-Off Handle.
7. Remove excess band from tool and dispose.
8. Inspect Shield Termination.

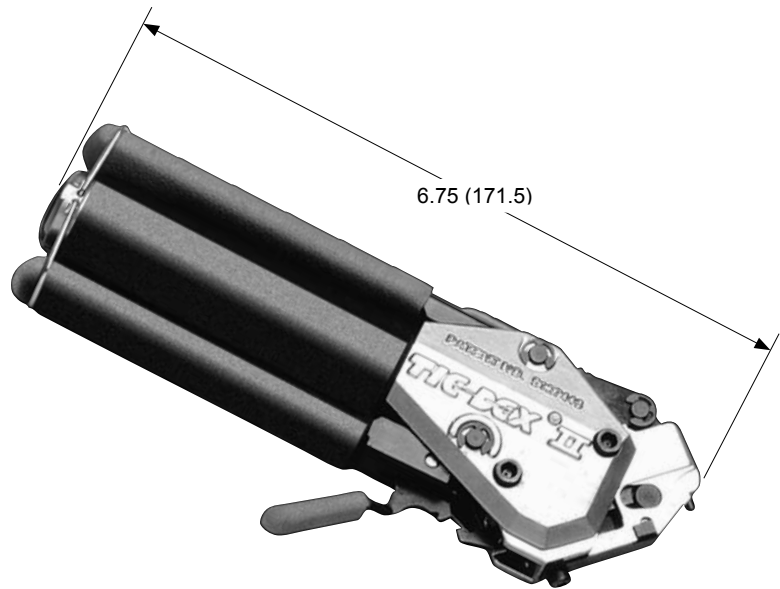


**IMPORTANT:** Always roll band through the buckle slot twice (see Step 3). Bands must be double-coiled to function correctly. The failure to roll the band through the buckle slot twice is the most common user error in band style terminations.

## Hand Banding Tool 600-058

The **600-058 Hand Banding Tool** weighs 1.18 lbs., and is designed for standard clamping bands 600-052 and 600-090 (see page 36) in a tension range from 100 to 180 lbs. Calibrate at 150 lbs.  $\pm$  5 lbs. for most shield terminations. Tool and band should never be lubricated.

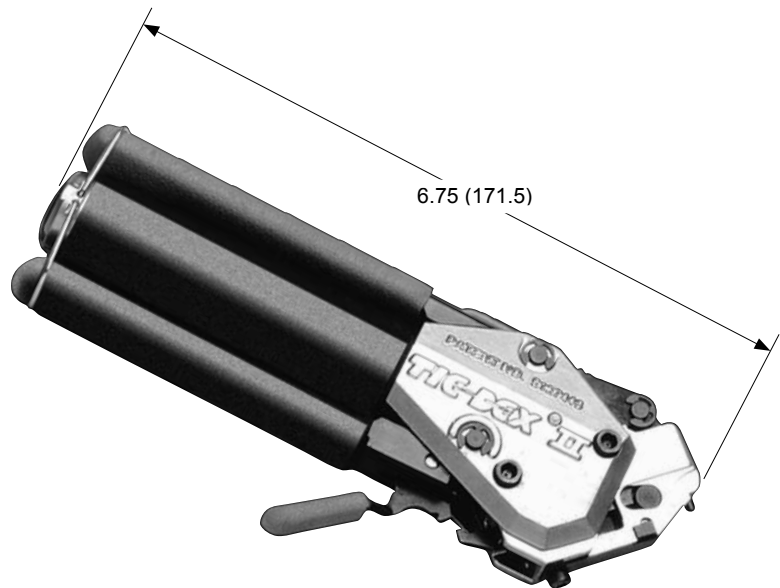
Reference: **BAND-IT®** part number A40199.



## Hand Micro Banding Tool 600-061

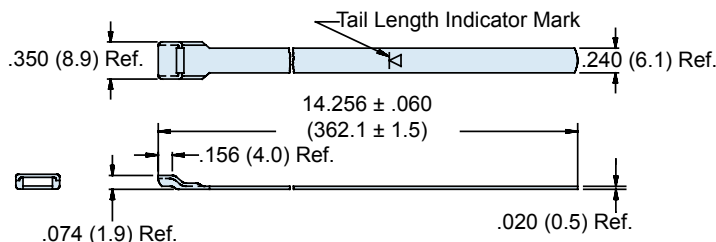
The **600-061 Hand Micro Banding Tool** weighs 1.18 lbs., and is designed for micro clamping bands 600-057 and 600-083 (see page 36) in a tension range from 50 to 85 lbs. Calibrate at 80lbs +2 lbs. -7 lbs. for most shield terminations. Tool and band should never be lubricated.

Reference: **BAND-IT®** part number A30199.



Metric Dimensions (mm) are indicated in parentheses.

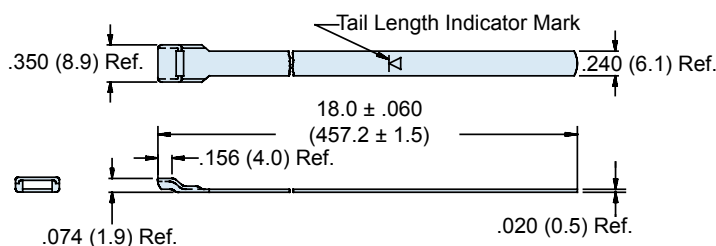
### Standard Band 600-052 and Precoiled Standard Band 600-052-1



**The 600-052 Standard Band** is precision constructed of 300 Series SST/Passivate and designed for use with the 600-058 Hand Banding Tool or the 600-067 Pneumatic Banding Tool. Double-wrapped bands will accommodate diameters up to approximately 1.8 inches (45.7). Bands may be ordered flat (600-052) or precoiled (600-052-1). Bands come bagged and tagged in quantities from 1 to 100.

Reference: **BAND-IT®** part number A10086

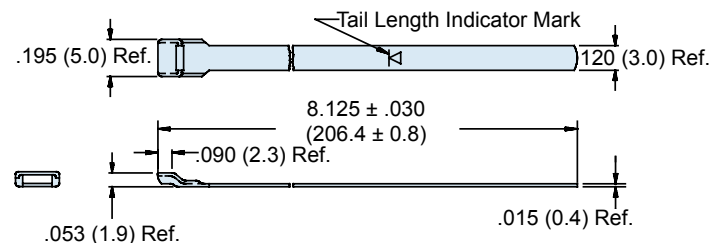
### Extended-Length Standard Band 600-090 & Precoiled Extended-Length Standard Band 600-090-1



**The 600-090 Extended Length Standard Band** is precision constructed of 300 Series SST/Passivate, and designed for use with the 600-058 Hand Banding Tool or the 600-067 Pneumatic Banding Tool. Double-wrapped bands will accommodate diameters up to approximately 2.5 inches (63.5). Bands may be ordered flat (600-090), or precoiled (600-090-1). Bands come bagged and tagged in quantities from 1 to 100.

Reference: **BAND-IT®** part number A11086

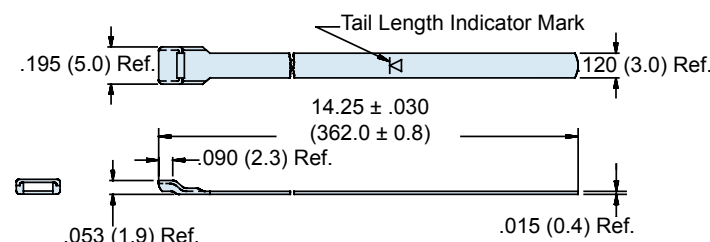
### Micro-Band 600-057 Precoiled Micro-Band 600-057-1



**The 600-057 Micro Band** is precision constructed of 300 Series SST/Passivate, and designed for use with the 600-061 Hand Banding Tool or the 600-068 Pneumatic Banding Tool. Double-wrapped bands will accommodate diameters up to approximately .88 inches (22.4). Bands may be ordered flat (600-057), or precoiled (600-057-1). Bands come bagged and tagged in quantities from 1 to 100.

Reference: **BAND-IT®** part number A31186

### Extended Length Micro-Band 600-083 Precoiled Micro-Band 600-083-1

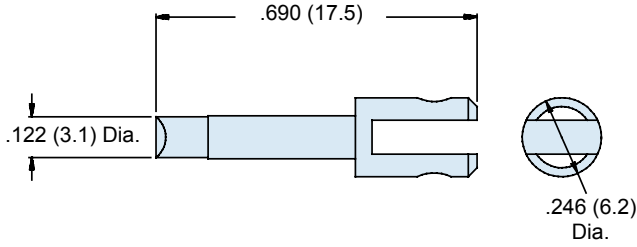


**The 600-083 Extended Length Micro-Band** is precision constructed of 300 Series SST/Passivate, and designed for use with the 600-061 Hand Banding Tool or the 600-068 Pneumatic Banding Tool. Double-wrapped bands will accommodate diameters up to approximately 1.88 inches (47.8). Bands may be ordered flat (600-083), or precoiled (600-083-1). Bands come bagged and tagged in quantities from 1 to 100.

Reference: **BAND-IT®** part number A31086.

Metric dimensions (mm) are indicated in parentheses. Consult factory for diameters above 2.5 inches (63.5).

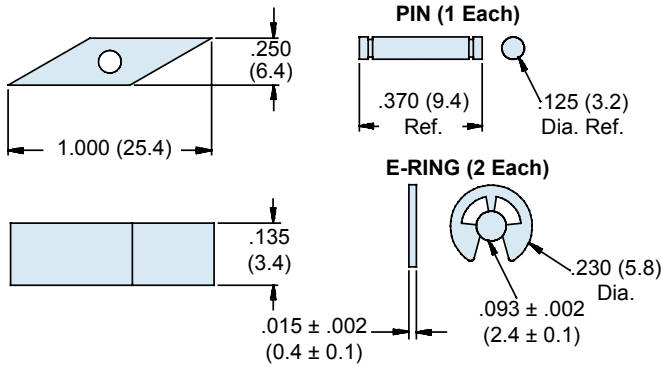




### 600-082 Cutter Knife

*The 600-082 Cutter Knife* replaces the cutter knife on the 600-061 Hand Banding Tool, and the 600-068 Pneumatic Banding Tool. Material is heat treated steel finished with black oxide and rust preventative.

Reference: **BAND-IT®** part number **A48087**

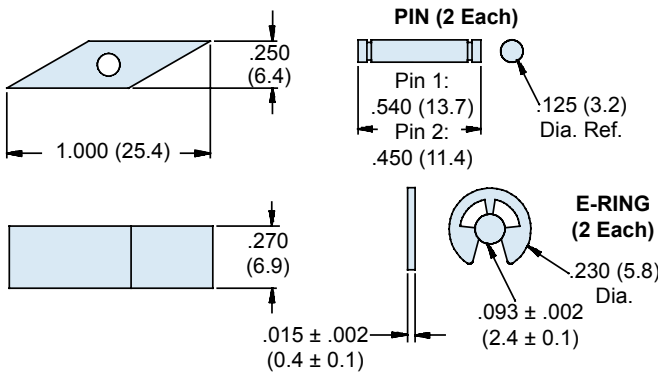


### 600-060-1 Micro Cut-Off Blade Kit

*The 600-060-1 Micro Cut-Off Blade Kit* for Serial Numbers up to 20999 consists of the blade, two E-rings and one pin, providing all parts needed to replace the cut-off blade on the 600-061 Hand Micro Banding Tool and the 600-068 Pneumatic Micro Banding Tool. Material is heat treated steel finished with black oxide and rust preventative.

Reference: **BAND-IT®** part number **A43999**.

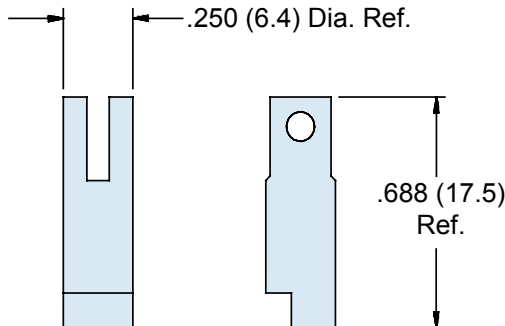
**600-060-2 Ref. BAND-IT® P/N A47899** for Serial Numbers **21000** and above.



### 600-056 Cut-Off Blade Kit

*The 600-056 Cut-Off Blade Kit* consists of the blade, two E-rings and one pin, providing all parts needed to replace the cut-off blade on the 600-058 Hand Banding Tool and the 600-067 Pneumatic Banding Tool. Material is heat treated steel finished with black oxide and rust preventative.

Reference: **BAND-IT®** part number **A40699**.



### 600-062 Cutter Knife

*The 600-062 Cutter Knife* for Serial Numbers up to 16589 replaces the cutter knife on the 600-058 Hand Banding Tool and the 600-067 Pneumatic Banding Tool. Material is heat treated steel finished with black oxide and rust preventative.

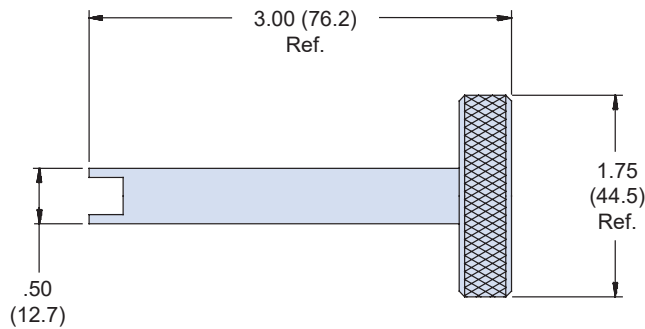
Reference: **BAND-IT®** part number **A40788**.

**600-062-1** for Serial Numbers **16590** and above.

Reference: **BAND-IT®** part number **A67787**.

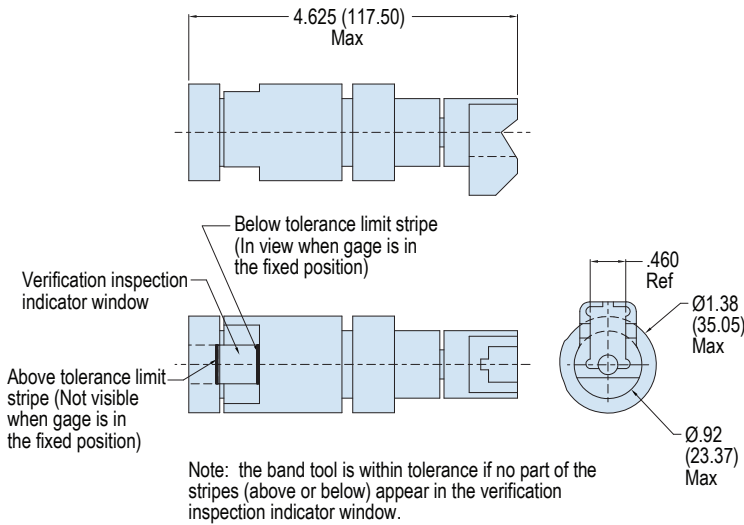
Metric Dimensions (mm) are indicated in parentheses.

# 601-205 Calibration Key and 601-211 Standard and 601-212 Micro Banding Tool Tension Gauges



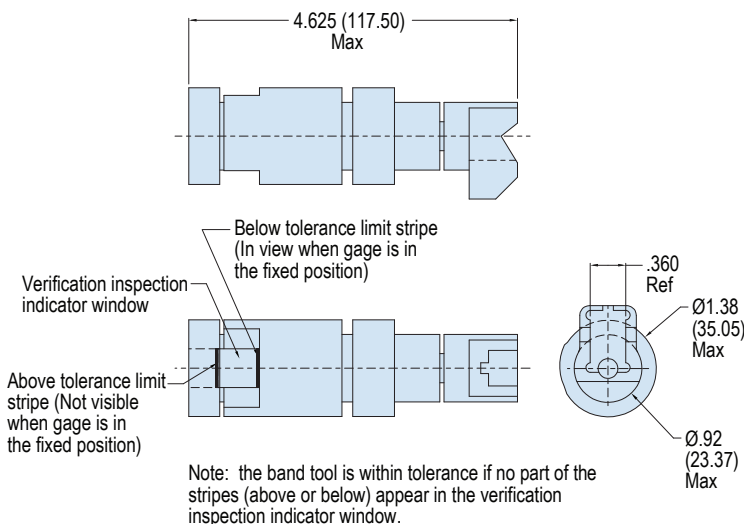
## 601-205 Calibration Key (Replaces 600-055)

**The 601-205 Calibration Key** is designed for use with 600-058, 600-061, 601-211 and 601-212 manual banding tools. Material is black anodized aluminum alloy. One full turn clockwise will advance the tension range approximately 1.0 - 2.5 lbs, a counter-clockwise turn will decrease tension by the same amount.



## 601-211 Tension Gauge (Replaces 600-072-1)

**The 601-211 (M81306/1C) Tension Gauge** is used to check and calibrate the manual tool to values noted on calibration sticker. Constructed of hardened steel.



## 601-212 Tension Gauge (Replaces 600-086-1)

**The 601-212 (M81306/1D) Tension Gauge** is used to check and calibrate the manual tool to values noted on calibration sticker. Constructed of hardened steel.



Metric Dimensions (mm) are indicated in parentheses.

# Cad-Free Ni-PTFE Plating: Now From Glenair

## Conductive Nickel-Fluorocarbon Polymer Plating Process Breaks 1000 Hr. Salt-Spray Barrier!



**New Cadmium Free  
RoHS Compliant  
Plating Solution for  
EMI/RFI Interconnect  
Applications**

*The MIL-DTL-38999 Rev. L detail specification establishes several new cadmium-free conductive plating solutions including high-performance nickel-fluorocarbon polymer. Glenair's Ni-PTFE meets all D38999 performance requirements including a shell-to-shell conductivity maximum 2.5 millivolt drop potential.*

*1000 Hour Grey™ delivers outstanding performance in a broad range of land, sea, air and space interconnect applications. The non-reflective, non-magnetic, gun-metal gray surface finish is an ideal choice for tactical military systems with extraordinary corrosion protection requirements.*

## **Advanced Durability, Lubricity Plus Outstanding Temperature Resistance!**

*The mechanical, electrical and environmental performance of the Glenair Ni-PTFE plating is truly outstanding, far surpassing that of other composite alloy/fluorocarbon polymer solutions:*

- 2000+ Hrs. Salt Spray (Composite)
- -65°C to 175°C Temp. Rating
- 336+ Hr. Sulfur Dioxide Resistance
- Non-Magnetic
- Cadmium Free
- Low Coefficient of Friction
- Hexavalent Chromium Free
- Potassium Formate Resistant
- Low Shell-to-Shell Resistance
- Adheres to Composite Plastic
- 500+ Mating Cycles
- Low Outgassing



**Glenair, Inc.**

1211 Air Way • Glendale, CA 91201-2497 • Tel: 818-247-6000 • Fax: 818-500-9912 • E-Mail: sales@glenair.com

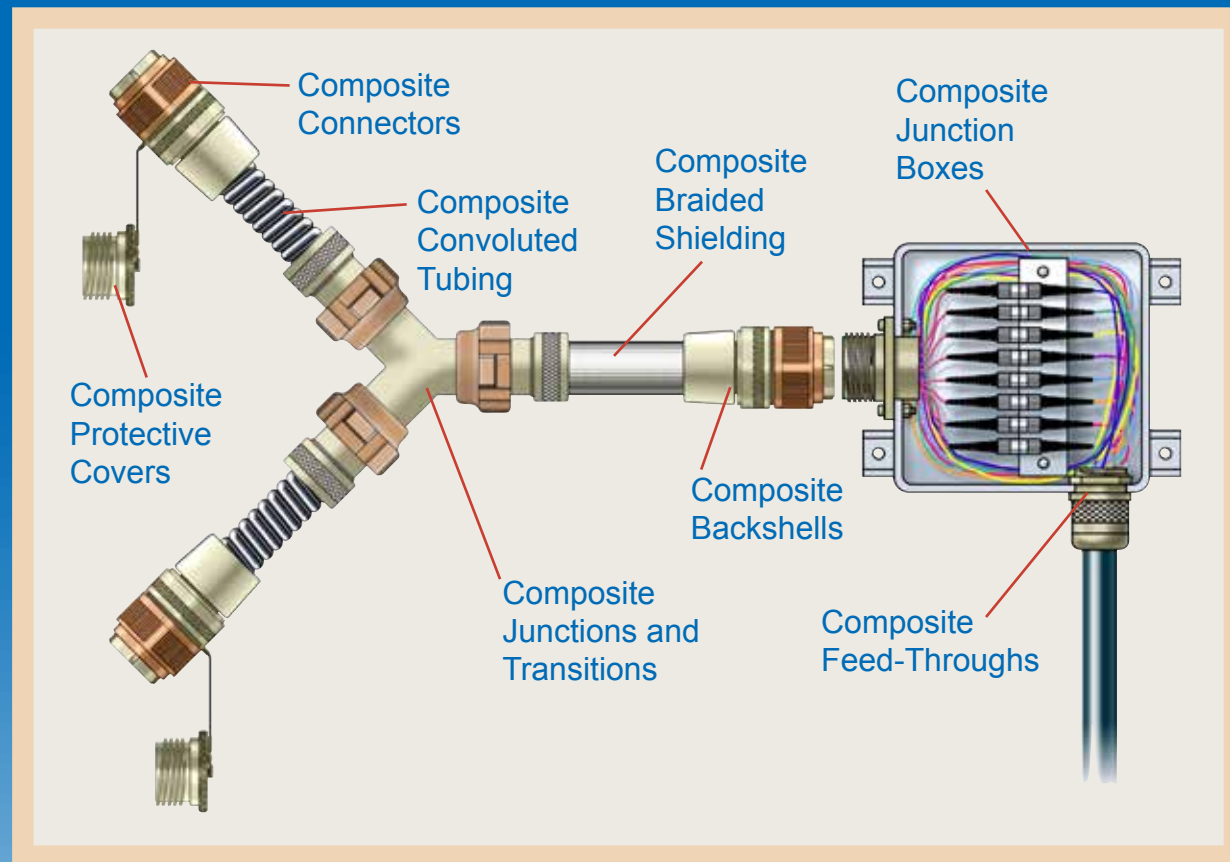
## Part Number Index

Part Number		Page
AS85049/93	687-749 Composite Banding Split-Ring	D-5
102-051	PEEK Tubular Braid (Black) for Series 74 Convuluted Tubing	D-4
103-026	Composite Light Weight Metal-Clad EMI/RFI Braided Shielding (100%)	D-2
103-027	75%/25% Blended Composite/Metal EMI/RFI Braided Shielding	D-3
107-044	EMI/RFI Nickel Plated Copper Knit Braid Material	A-55
120-100	Type A - Convuluted Tubing Only - Series 74 Convuluted Tubing	C-7
120-103	Type B - External Black Dacron® Braid - Series 74 Convuluted Tubing	C-8
121-100	Type C - External Shield and Jacket - Series 74 Convuluted Tubing	C-9
121-101	Type D - External Shield - Series 74 Convuluted Tubing	C-10
121-102	Type E - Two External Shields - Series 74 Convuluted Tubing	C-11
121-103	Type F - Jacket and Two External Shields - Series 74 Convuluted Tubing	C-12
123-100	Type G - External Jacket - Series 74 Convuluted Tubing	C-13
140-060	Grounded Composite Junction Box (NSN: 5975-01-557-2679)	E-16
140-074	Ultra-Miniature Junction Box	E-18
140-100	Mini Junction Box	E-20
140-101	Small Junction Box	E-22
140-102	Medium Junction Box	E-24
140-103	Large Junction Box	E-26
140-104	Small Low-Profile Box	E-28
140-105	Medium Low-Profile Junction Box	E-30
140-106	Small Three-Legged Junction Box	E-32
140-107	Jumbo Junction Box	E-34
140-200	8 Port Octagonal Junction Box	E-36
140-203	12 Port Rectangular Junction Box	E-37
233-105-05	MIL-DTL-38999 Series III Type In-Line Receptacle	F-14
233-105-07	MIL-DTL-38999 Series III Type Jam Nut Receptacle	F-12
233-105-G6	MIL-DTL-38999 Series III Type Plug	F-16
233-105-XX	MIL-DTL-38999 Series III Type Wall Mount Receptacle w/ Round (D0), Slotted (00) and Tapped (T0) Holes	F-10
310-017	Shrink Boot Adapter with Direct Coupling - Straight	A-4
310-045	Shrink Boot Adapter with Rotatable Coupling Nut; Straight	A-2
311-019	Lamp Base EMI/RFI Shield Termination Backshell with Shrink Boot Porch - Straight, 45° and 90°	A-6
311-034	Lamp Base EMI/RFI Shield Termination Backshell - Straight and 90°	A-5
311-063	Lamp Base EMI/RFI Environmental Adapter with Shrink Boot Porch and Direct Coupling - Straight	A-8
319-064	Swing Arm Backshell with Shield Sock and Self-Locking Rotatable Coupling - Adjustable to Straight, 45° and 90°	A-12
319-120	EMI/RFI Backshell with Shield Sock and Self-Locking Rotatable Coupling - Straight Only	A-14
319-134	EMI/RFI Micro Banding Backshell Shield Sock with Shrink Boot Porch and Self Locking Rotatable Coupling	A-16
319-136	EMI/RFI Standard Banding Backshell Shield Sock with Shrink Boot Porch and Self Locking Rotatable Coupling	A-18
319-137	Shield Sock Strain Relief with Self Locking Rotatable Coupling - Straight, 45° and 90°	A-22
319-138	Wide Mouth Swing Arm Strain Relief with Shield Sock and Self Locking Rotatable Coupling - Straight, 45° and 90°	A-24
327-060	Extender Backshell with Self-Locking Rotatable Coupling - Straight, 45° and 90°	A-26
347-129	Shorting Cap Backshell with Lanyard Attachment and Self Locking Rotatable Coupling	A-28
360-014	Non-Environmental Backshell with Self Locking Rotatable Coupling and Strain Relief - Straight and 90°	A-32
360-015	Non-Environmental Backshell with Self Locking Rotatable Coupling and Qwik-Clamp - Straight, 45° and 90°	A-34
370-016	Cable Sealing and Environmental Backshell with Self Locking Rotatable Coupling and Strain Relief Clamp or Nut	A-38
370-017	Cable Sealing and Environmental Backshell with Self Locking Rotatable Coupling and Qwik-Clamp or Nut	A-40
377-040	Fiber Optic Strain Relief Backshell with Fiber Alignment Grommet and Optional Banding adapter or Nut	A-42
377-041	Fiber Optic Conduit Backshell Adapter with Self Locking Rotatable Coupling and Fiber Alignment Grommet	C-14
380-099	Cone and Ring Style Shield Termination Backshell with Self Locking Coupling Nut and Strain Relief	A-46
380-100	Cone and Ring Style EMI/RFI Backshell with Self Locking Rotatable Coupling and Qwik-Clamp	A-48
380-130	Knit Braid Style EMI/RFI Shield Termination Backshell with Qwik-Ty and Rotatable Coupling	A-52
380-131	Knit Braid Style EMI/RFI Shield Termination Backshell with Clamp and Rotatable Coupling	A-53
380-132	Knit Braid Style EMI/RFI O-Ring Equipped Shield Termination Backshell with Shrink Boot Adapter	A-54
387-083	Multi Shield Cone and Ring Style EMI/RFI Shield Termination Backshell with Strain Relief	A-58
390-052	Environmental Cone and Ring Style EMI/RFI Shield Termination Backshell with Strain Relief	A-62
440-087	Ultra Lightweight Banding Strain Relief with Rotatable Coupling	A-64
440-143	EMI/RFI Micro-Banding Backshell with Qwik-Ty Strain Relief, Shrink Boot Groove	A-68
440-144	EMI/RFI Micro-Banding Backshell with Shrink Boot Groove and Self Locking Rotatable Coupling	A-70
447-325	EMI/RFI Banding Backshell with Shrink Boot Groove and Self Locking Rotatable Coupling	A-72
447-326	EMI/RFI Micro-Banding Backshell with Shrink Boot Groove and Self Locking Rotatable Coupling	A-74
447-327	EMI/RFI Banding Backshell with Qwik-Ty Strain Relief and Shrink Boot Groove	A-76

## Part Number Index

Part Number		Page
447-328	EMI/RFI Band-in-a-Can Backshell with Strain Relief Clamp - Standard Profile Straight and 90°	A-78
447-329	EMI/RFI Environmental Band-in-a-Can Backshell with Strain Relief Clamp or Qwik-Clamp	A-80
447-330	EMI/RFI Non-Environmental Band-in-a-Can Backshell w/ Qwik-Clamp and Self-Locking Rotatable Coupling	A-82
447-331	EMI/RFI Dual Banding Backshell with Self Locking Rotatable Coupling - Straight and 90°	A-84
447-657	EMI/RFI Low Profile Micro Band-in-a-Can Backshell with Strain Relief Clamp	A-86
447-711	EMI/RFI Banding Backshell with Strain Relief - Standard Profile Straight and 90°	A-87
450-029	Qwik-Ty Strain Relief with Self Locking Rotatable Coupling - Straight, 45° and Low Profile 90°	A-88
450-030	Qwik-Ty Strain Relief with Ground Lug and Self Locking Rotatable Coupling	A-89
450-034	Ultra Lightweight Qwik-Ty Strain Relief with Free Rotating Coupling - Straight and Low Profile 90°	A-90
507-088	EMI/RFI Banding Backshell for MIL-DTL-83513 Micro-D Connectors - Top, 45° and Side Entry	A-92
557-186	EMI/RFI Banding Backshell for MIL-DTL-24308 D-Subminiature Connectors - Top, Side and End Entry	A-94
600-052	Standard Clamping Band	G-13
600-055	Calibration Key for Standard and Micro Hand Banding Tools	G-15
600-056	Cut-Off Blade for Standard Hand Banding Tools	G-14
600-057	Micro Clamping Band	G-13
600-058	Hand Banding Tool for Standard Bands	G-12
600-060	Cut-Off Blade for Micro Hand Banding Tools	G-14
600-061	Hand Banding Tool for Micro Bands	G-12
600-062	Cutter Knife for Standard Hand Banding Tools	G-14
600-072-1	Tension Gauge for Standard Hand Banding Tools	G-15
600-082	Cutter Knife for Micro Banding Tools	G-14
600-083	Micro Extended-Length Clamping Band	G-13
600-086-1	Tension Gauge for Micro Hand Banding Tools	G-15
600-090	Standard Extended-Length Clamping Band	G-13
600-091	Aluminum Hex-Coupling Wrench for Composite Backshells	G-6
600-157	Stainless Steel Hex-Coupling Wrench for Composite Backshells	G-7
600-161	Hand-Held Digital Torque Wrench with Dual 3/8" Drives	G-9
600-162	Bench Stand for 600-161 Digital Torque Wrench	G-9
600-164	Large Broad Blade Utility Shears	G-10
610-014	E Nut Backshell	A-96
620-042	Strain Relief Clamp with Self-Locking Rotatable Coupling - Straight, 45° and 90°	A-97
627-122	Swing Arm Strain Relief with Self Locking Rotatable Coupling Nut	A-98
627-142	Swing Arm Strain Relief with Keyed Banding Insert and Self Locking Rotatable Coupling Nut	A-100
630-031	Composite Through-Box Panel and Bulkhead Universal Environmental Adapter	E-40
637-094	Composite Box Conduit or Cable Feed-Through Adapter Series	E-42
637-094	EMI/RFI Environmental Bulkhead Feedthru Cable / Conduit Adapter	E-40
650-025	MIL-DTL-38999 Series III Dummy Stowage Receptacle	B-8
660-045 / 046	MIL-DTL-5015 Plug and Receptacle Covers	B-3
660-047 / 048	MIL-DTL-28840 Plug and Receptacle Covers	B-4
660-049 / 050	MIL-DTL-38999 Series III Plug and Receptacle Covers	B-5
660-051 / 052	MIL-DTL-83723 Series III Plug and Receptacle Covers	B-7
660-077 / 078	Glenair Series 190-015 / 016 Plug and Receptacle Covers	B-6
667-079	MIL-DTL-38999 Series III Receptacle Cover with Anti-Rotation Device	B-11
667-117	MIL-DTL-38999 Series III Receptacle Cover with Anti-Decoupling Device	B-9
667-118	MIL-DTL-5015 Receptacle Cover with Anti-Decoupling Device	B-10
687-466	Terminal Rail and Block Mounting Plate to fit Rectangular Boxes	E-44
687-305-22	Round Internal Mounting Plate to fit Three-Legged Boxes	E-45
687-467	Slotted Terminal Block Mounting Rail	E-46
687-461	Hole Cap Assembly	E-47
687-749	AS85049/93 Composite Banding Split-Ring	D-5
710-318	T Configuration Split Junction Fitting	C-16
710-319	Y Configuration Split Junction Fitting	C-17
710-320	Straight with 45° Branch Configuration Split Junction Fitting	C-18
710-321	Plus "+" Configuration Split Junction Fitting	C-19
712-419	Straight, 45° and 90° Conduit Connector Adapter for Glenair Series 74 Helical Convuluted Tubing	C-24
712S269	Shrink Boot Conduit Fitting for Glenair Series 74 Helical Convuluted Tubing	C-20
712S270	Single EMI/RFI Shield Termination Conduit Fitting for Glenair Series 74 Helical Convuluted Tubing	C-21
712S271	Dual EMI/RFI Shield Termination Conduit Fitting for Glenair Series 74 Helical Convuluted Tubing	C-22
770-001	Heat Moldable Shrink Boot - Straight and 90°	A-102

# Composite Thermoplastic



## Soup to Nuts

Composite thermoplastic interconnect components are nothing new. Plenty of manufacturers can offer you a selection of these weight-saving, corrosion-free products. But only Glenair has made an across-the-board commitment to integrate composite solutions into every facet of the interconnect system.

Glenair can offer today's interconnect engineer the ability to design and build next-

generation interconnect cable, box and conduit systems exclusively from composites. From the connector to the backshell, from the dust-cap to the junction box, from the feed-through to the shielding, from the conduit to the transition—Glenair offers you the freedom to build interconnect systems which are not only light weight and corrosion-free, but just as tough on EMI as traditional metal components. Soup to nuts.



1211 Air Way  
Glendale, California 91201-2497

Telephone: 818-247-6000 · Facsimile: 818-500-9912 · E-mail: sales@glenair.com

United States · United Kingdom · Germany · Nordic France · Italy · Spain · Japan

www.glenair.com

# Glenair®

## A World of Interconnect Solutions

### Glenair, Inc.

1211 Air Way • Glendale, California • 91201-2497  
Telephone: 818-247-6000 • Fax: 818-500-9912 • sales@glenair.com  
www.glenair.com

**Glenair Industrial Power and Signal Connector Group**  
25 Village Lane  
Wallingford, CT 06492

Telephone: 203-741-1115  
Facsimile: 203-741-0053  
sales@glenair.com

### Glenair UK Ltd

40 Lower Oakham Way  
Oakham Business Park  
P.O. Box 37, Mansfield  
Notts, NG18 5BY England

Telephone: 44-1623-638100  
Facsimile: 44-1623-638111  
sales@glenair.co.uk

**Glenair Microway Systems**  
7000 North Lawndale Avenue  
Lincolnwood, IL 60712

Telephone: 847-679-8833  
Facsimile: 847-679-8849

### Glenair Nordic AB

Gustav III : S Boulevard 46  
S - 169 27 Solna  
Sweden

Telephone: 46-8-50550000  
Facsimile: 46-8-50550001  
sales@glenair.se

### Glenair Electric GmbH

Siemensstrasse 9  
D-61449 Steinbach  
Germany

Telephone: 49-6171-5905-0  
Facsimile: 49-6171-5905-90  
germany@glenair.com

### Glenair Iberica

C/ La Vega, 16  
45612 Velada  
Spain

Telephone: 34-925-89-29-88  
Facsimile: 34-925-89-29-87  
sales@glenair.es

### Glenair Italia S.R.L.

Via Santi, 1  
20037 Paderno Dugnano  
Milano, Italy

Telephone: 39-02-91082121  
Facsimile: 39-02-99043565  
sales-italia@glenair.it

### Glenair France SARL

7, Avenue Parmentier  
Immeuble Central Parc #2  
31200 Toulouse  
France

Telephone: 33-5-34-40-97-40  
Facsimile: 33-5-61-47-86-10  
sales@glenair.fr

© 2009 Glenair, Inc.

Printed in U.S.A.