

# 710-321 Composite Split Junction Fitting Plus ("+") Configuration

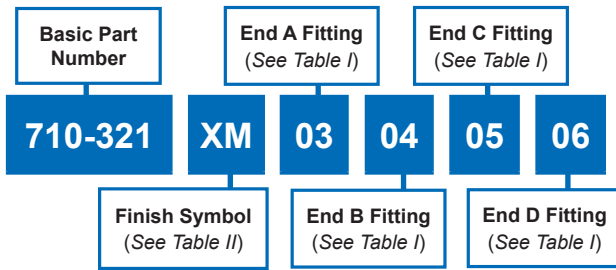

**APPLICATION NOTES**

1. Metric dimensions (mm) are in parentheses and are for reference only.
2. Transitions mate to 710S269, S270 and S271 adapters.
3. When all ends are identical, insert only one dash number. When multiple dash numbers are ordered, transition size will be determined by the largest. Adapter may be supplied on smaller entries. Letter to follow entry will be supplied with adapters.

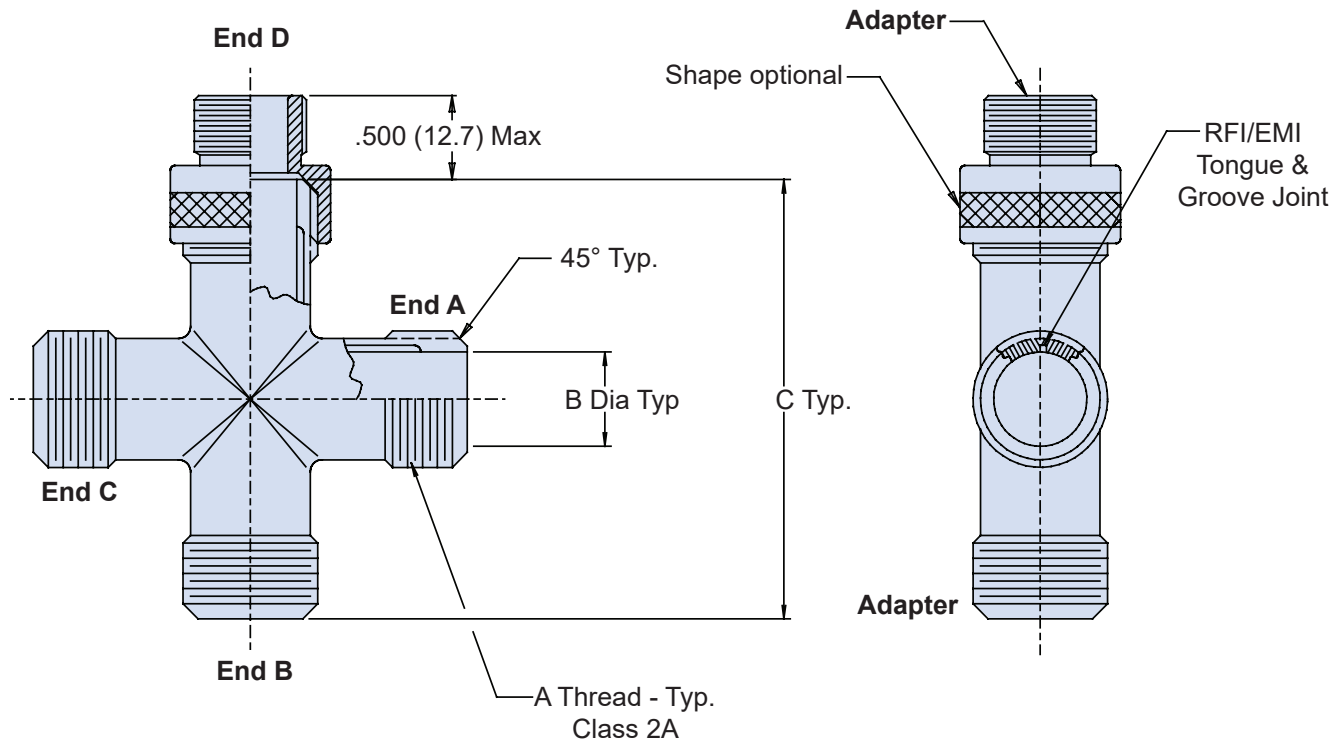

**TABLE I: END ORDER NUMBER AND DIMENSIONS**

End No.	A Thread Unified	B Dia	C Max	Weight in Pounds Max.
01	.750 - 20	.500 (12.7)	2.375 (60.3)	.109
02	1.000 - 20	.750 (19.1)	2.625 (66.7)	.152
03	1.312 - 18	1.000 (25.4)	2.875 (73.0)	.213
04	1.500 - 18	1.250 (31.8)	3.125 (79.4)	.254
05	2.000 - 18	1.625 (41.3)	3.500 (88.9)	.364
06	.500 - 20	.281 (7.1)	2.125 (54.0)	.041
07	.625 - 24	.375 (9.5)	2.250 (57.2)	.057

**Table II: Finish**

Code	Finish Description
XM	1000 Hr. Corrosion-Resistant Electroless Nickel
XW	1000 Hr. Corrosion-Resistant Cadmium Olive Drab over Electroless Nickel
XB	No Plating - Black Color
XV	No Plating - Purple Color

