



SERIES 77

Lipped Shrink Boots



Shrink Boot Selection and Reference Guide

Lipped Straight, 90° and 45° Angle Shrink Boots



- Easy attachment to shrink boot adapters
- Eight material options
- Four adhesive options
- With or without eyelets
- With or without potting ports or drain holes
- Non-adhesive lined boots (For use with Type U two-part epoxy):



Part Number
779-001



Part Number
779-002

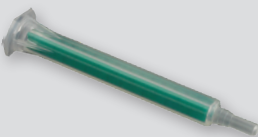

Part Number	Package Size
779-003	12

See Section G for complete installation guide

Lipped shrink boots can be attached to connectors with integral boot grooves or onto shrink boot adapters. Once recovered boots lock into boot groove to provide a robust water-tight fit. Boots are available with or without eyelet hole, allowing for convenient attachment of protective covers and can be ordered in straight, 90°, 45° and 30° angle configurations. Shrink boots provide environmental and mechanical protection as well as wire strain relief.

Recommended Material Selection

Type 1 high performance, semi-rigid elastomer for extreme temperatures and excellent resistance to fuels and oils and rated for 3000 hours continuous operation at +150°C. Material meets requirements of VG95343 Type 6, BSG 198-5-DE, EN62329-102 and SAE AS5258 Type H. Temperature rating -75°C to 150°C

Type 2 semi-flexible low smoke zero halogen (LSZH) flame-retarded polyolefin meets low smoke and toxicity requirements of shipboard, transit and aircraft systems and rated for 3000 hours continuous operation at +130° C. Temperature rating -40° C to +130°C. Material meets the requirements of SAE AS5258 Type G.

Type 3 self extinguishing, flexible polyolefin boots meet SAE AS81765 Type II requirements and offers good resistance to oils and fuels. Good all around general duty shrink boot solution. Temperature rating of -55° C to +135°C. Material Meets the Requirements of SAE AS5258 Type B.

Type 5 flexible Viton® Fluoroelastomer boot for extreme temperatures where excellent resistance to fuels, fluids, solvents is needed. Temperature rating of -55° C to +150°C. Material meets the requirements of SC-X15111D.

Type 6 high performance, flexible elastomer alloy are well suited for high temperatures within areas prone to oil and fluid exposure. Temperature rating of -55° to +135°C. Material meets the requirements of SC-X15112C.

Type 7 highly flexible polyolefin boots are well suited for high temperatures within areas prone to oil and fluid exposure. Temperature rating of -55° to +135°C. Material meets the requirements of SAE AS5258 Type A.

Type 8 semi-rigid, low outgassing fluoropolymer alloy meets NASA low out-gassing test requirements and are suitable for high altitude and space applications. Excellent resistance to oils, fuels, solvents, acids and bases. Broad operating temperature of -50° C to +175° C provides excellent high temperature stability and low temperature flexibility for extreme temperatures. The recommended Adhesive is 779-001 two-part epoxy.

Type 9 low temp application, flexible polyolefin for Ethernet and USB cables susceptible to heat damage from the application of boots with higher minimum shrink temperatures. Resistance to oils, fuels, solvents, acids and bases is fair. Temperature rating of -40° to +100°C.



SERIES 77

Lipped Shrink Boots

Shrink Boot Selection and Reference Guide

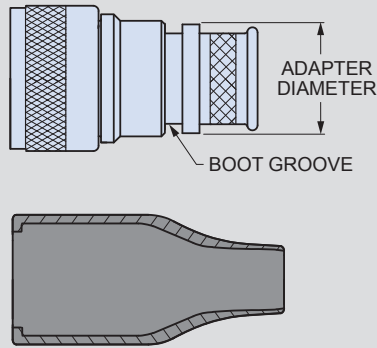

Boot Size	Adapter Diameter		Min. Cable Diameter	Boot Size	Adapter Diameter		Min. Cable Diameter
	Min	Max	In.		Min	Max	In.
00S	.250 (6.35)	.325 (8.26)	.110 (2.79)	06	.900 (22.86)	1.350 (34.29)	.375 (9.53)
00	.250 (6.35)	.325 (8.26)	.110 (2.79)	07	1.250 (31.75)	1.650 (41.91)	.425 (10.80)
01	.325 (7.62)	.425 (10.80)	.150 (3.81)	08	1.400 (35.56)	2.250 (57.15)	.625 (15.88)
02	.350 (8.89)	.600 (15.24)	.175 (4.45)	09	1.870 (47.50)	2.470 (62.70)	.700 (17.78)
03	.450 (11.43)	.850 (21.59)	.225 (5.72)	10	2.38 (60.45)	3.25 (82.55)	1.10 (27.94)
04	.600 (15.24)	1.000 (25.40)	.275 (6.99)	11	.325 (8.25)	.425 (10.80)	.120 (3.05)
05	.750 (19.05)	1.200 (30.48)	.300 (7.62)	12	.425 (10.80)	.600 (15.24)	.220 (5.59)

Table 2: Material Selection Guide

Material Type	Flexibility	Continuous Operating Temp.	Resistance to Fuels, Oils	Flammability	Low Temperature Flexibility	Low Toxicity, Zero Halogen
Type 1 High-Performance Semi-Rigid Elastomer	Semi-rigid	-75° C to +150° C	Excellent	Self-Extinguishing <15 Sec	-75° C	No
Type 2 Zero Halogen Semi-Rigid Polyolefin	Semi-flexible	-40° C to +130° C	Very Good	Self-Extinguishing <15 Sec	-40° C	Yes
Type 3 General Purpose Flexible Polyolefin	Flexible	-55° C to +135° C	Good	Self-Extinguishing <120 Sec	-55° C	No
Type 5 Viton Fluoroelastomer Blend	Flexible	-55° C to +150° C	Excellent	Self-Extinguishing <60 Sec	-65° C	No
Type 6 High Performance Elastomer Alloy	Flexible	-55° C to +135° C	Excellent	Self-Extinguishing <60 Sec	-65° C	No
Type 7 Semi-Rigid Polyolefin	Highly Flexible	-55° C to +135° C	Good	Self-Extinguishing <60 Sec	-55° C	No
Type 8 Low Outgassing Fluoropolymer Alloy	Semi-Rigid	-50° C to +175° C	Excellent	Self-Extinguishing <60 Sec	-50° C	No
Type 9 Low Temp Flexible Polyolefin	Flexible	-40° C to +100° C	Fair	Self-Extinguishing <120 Sec	-40° C	No

Table 2: Pre-Coated Boot Adhesive Information

Attribute	W1 High Performance Adhesive	W2 Low Temp Adhesive	W3 TACOM Approved Adhesive	R High Performance Epoxy Adhesive	779-001 Two Part Epoxy Adhesive
Boot Material Compatibility	Types 1, 2, 5, 6 and 7	Types 1, 2, 3, 7 and 9	Types 5 and 6	Type 1, 2 and 5	All Material Types
Continuous Operating Temp.	-55° to +125°C	-55° to +70°C	-55° to +125°C	-75° to +150°C	-75° to +150°C
Resistance to Fuels, Oils, and Fluids	Good	Good	Good	Excellent	Excellent
Low Toxicity, Zero Halogen	Yes	Yes	No	Yes	Yes