

QPL QUALIFIED

MIL-DTL-38999 Series III, Triple-Start Thread

D38999/20 wall mount receptacle with rear release crimp contacts and accessory threads



SERIES III ENVIRONMENTAL

QPL Part Number Development						
Sample Part Number	D38999/20	W	A	35	P	N
D38999 Series IV	D38999/20 = Wall mount receptacle					
Class	W = Environmental, aluminum, cadmium O.D. over electroless nickel (500 hour salt spray), -65°C to +175°C, conductive plating F = Environmental, aluminum, electroless nickel (48 hour salt spray), -65°C to +200°C, conductive plating G = Environmental, aluminum, electroless nickel (48 hour salt spray), matte finish, space grade, -65°C to +200°C, conductive plating T = Environmental, aluminum, Nickel-PTFE, -65°C to +175°C, conductive plating					
Shell Size Code	A, B, C, D, E, F, G, H and J (per MIL-STD-1560)					
Insert Arrangement	Per MIL-STD-1560; See reference information section for details					
Contact Type	P = Pin, 500 cycles A = Pin insert, less standard contacts S = Socket, 500 cycles B = Socket insert, less standard contacts					
Alternate Polarization	A, B, C, D, E, N = Normal					

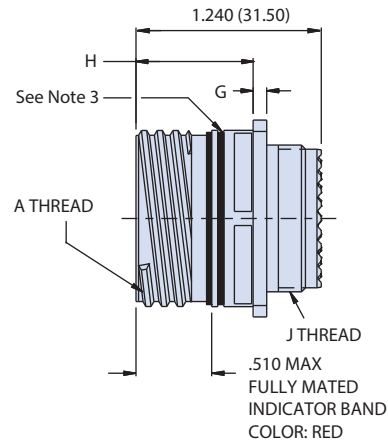
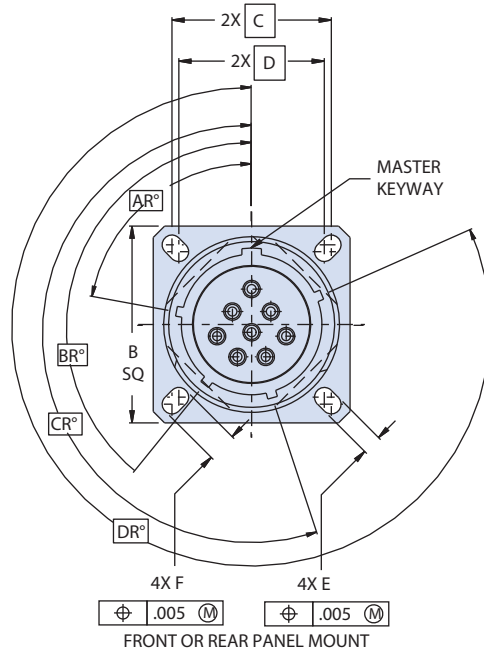

For recommended panel cut-out see reference information section

Series III Alternate Keyway Polarizations																				
Shell Size Code	Shell Size	Key and Keyway ID Letter	AR° BSC	BR° BSC	CR° BSC	DR° BSC	Shell Size Code	Shell Size	Key and Keyway Code	AR° BSC	BR° BSC	CR° BSC	DR° BSC	Shell Size Code	Shell Size	Key and Keyway ID Letter	AR° BSC	BR° BSC	CR° BSC	DR° BSC
A	9	N	105	140	215	265	B C D	11 13 15	N	95	141	208	236	E F G H J	17 19 21 23 25	N	80	142	196	293
		A	102	132	248	320			A	113	156	182	292			A	135	170	200	310
		B	80	118	230	312			B	90	145	195	252			B	49	169	200	244
		C	35	140	205	275			C	53	156	220	255			C	66	140	200	257
		D	64	155	234	304			D	119	146	176	298			D	62	145	180	280
		E	91	131	197	240			E	51	141	184	242			E	79	153	197	272

COTS EQUIVALENT MIL-DTL-38999 Series III, Triple-Start Thread



233-105-20 wall mount receptacle with rear release crimp contacts and rear accessory options

SERIES III ENVIRONMENTAL

COTS Part Number Development							
Sample Part Number	233-105-20	NF	11	-35	P	N	
Series / Basic Part No.	233-105-20 = Environmental, wall mount receptacle						
Material/Finish	NF = Aluminum, cadmium O.D. over electroless nickel (500 hour salt spray), -65°C to +175°C, conductive plating ME = Aluminum, electroless nickel (48 hour salt spray), -65°C to +200°C, conductive plating MA = Aluminum, electroless nickel (48 hour salt spray), matte finish, space grade, -65°C to +200°C, conductive plating MT = Aluminum, nickel-PTFE, -65°C to +175°C, conductive plating						
Shell Size	9, 11, 13, 15, 17, 19, 21, 23, 25						
Contact Arrangement	Per MIL-STD-1560; See reference information section for details						
Contact Type	P = Pin Insert A = Pin Gender, Less Contacts S = Socket Insert B = Socket Gender, Less Contacts						
Alternate Polarization	A, B, C, D, E, N (Normal), U (Universal)						
Optional Mod Codes	LC = Less contacts 186T = Thermal vacuum outgassing						

* Connectors must be ordered with "MA" finish and modification code "-186T" to conform to the thermal vacuum outgassing requirements of Class G. Additional material/finish options are available, consult factory for ordering information.

Dimensions										
Shell Size Code	Shell Size	A Thread .1P-.3L-TS-2A	B Sq	C BSC	D BSC	E	F	G	H	J Thread 1.0-6g 0.100R
A	09	.6250	.949 (24.10) .925 (23.50)	.719 (18.26)	.594 (15.09)		.224 (5.69) .208 (5.28)			M12
B	11	.7500	1.043 (26.49) 1.019 (25.88)	.812 (20.62)	.719 (18.26)		.202 (5.13) .186 (4.72)			M15
C	13	.8750	1.138 (28.91) 1.114 (28.30)	.906 (23.01)	.812 (20.62)			.098 (2.49)	.820 (20.83)	M18
D	15	1.0000	1.232 (31.29) 1.208 (30.68)	.969 (24.61)	.906 (23.01)	.136 (3.45) .120 (3.05)	.181 (4.60) .165 (4.19)	.083 (2.11)	.771 (19.58)	M22
E	17	1.1875	1.323 (33.60) 1.299 (32.99)	1.062 (26.97)	.969 (24.61)					M25
F	19	1.2500	1.449 (36.80) 1.425 (36.20)	1.156 (29.36)	1.062 (26.97)		.202 (5.13) .186 (4.72)			M28
G	21	1.3750	1.575 (40.00) 1.551 (39.40)	1.250 (31.75)	1.156 (29.36)					M31
H	23	1.5000	1.701 (43.21) 1.677 (42.60)	1.375 (34.92)	1.250 (31.75)			.126 (3.20)	.790 (20.07)	M34
J	25	1.6250	1.823 (46.30) 1.799 (45.69)	1.500 (38.10)	1.375 (34.92)	.162 (4.11) .146 (3.71)	.250 (6.35) .234 (5.94)	.083 (2.11)	.741 (18.82)	M37

Additional Material/Finish Options	
Finish Code	Description
ZR	Aluminum, zinc nickel-black
G2	Aluminum, hard, anodic, non conductive .0020 in min thickness

NOTES

1. Insert arrangements per MIL-STD-1560,
2. Connector is supplied with contacts (including spares), insertion/removal tool and sealing plugs unless otherwise specified.
3. Blue color band indicates rear release retention system.