

AS85049/112

Straight RFI/EMI Shield-Sock Shrink Boot Adapter with Optional Self-Locking Coupling Nut

CONNECTOR DESIGNATOR:

F MIL-DTL-38999 Series I and II

**Product Series and
Specification Sheet**
**Shell Size
(Table I)**
**Shield Finish
(Table IV)**
**Entry Size
(Table II)**
**Drain Hole
(Omit for None)**
M85049/112
S
10
T
W
03
- 6
D

S = Detented, Self-Locking
 - = Non-Self-Locking (Use Dash)
N = Non-Detented, Self-Locking

**Finish
(Table III)**

**Braid Length
1 Inch Increments,
6" Min., 18" Max**

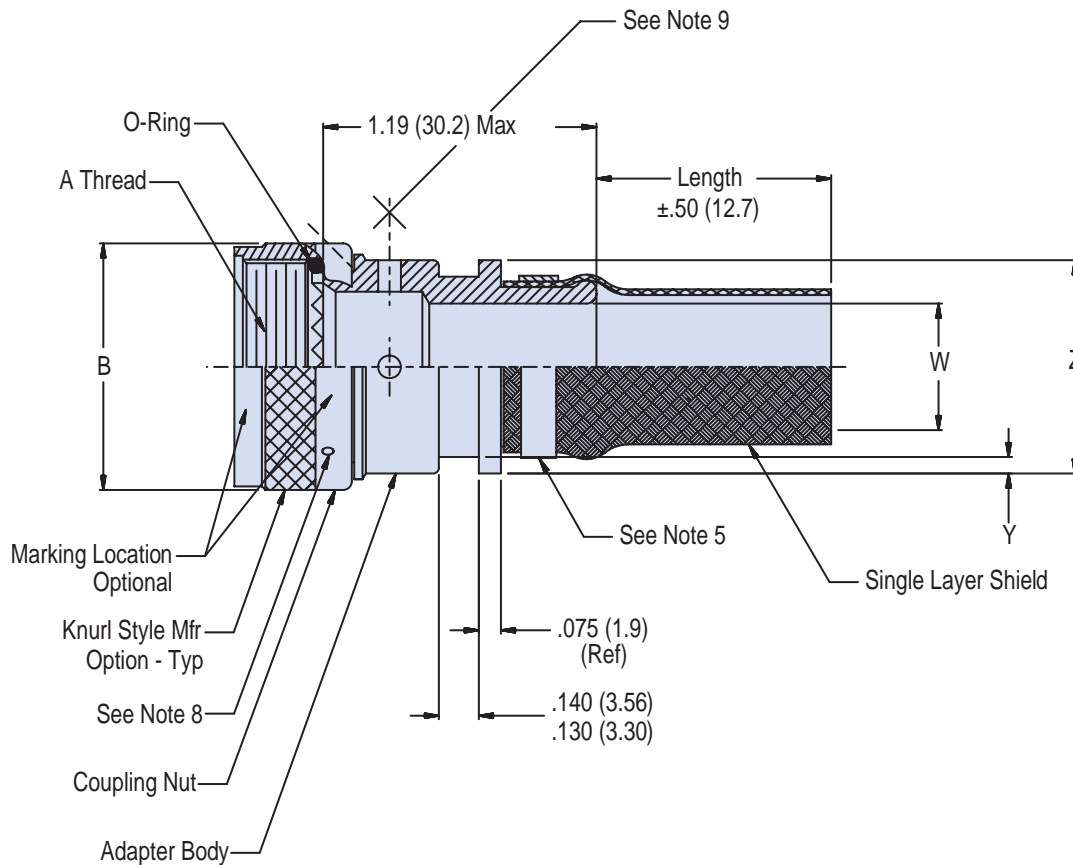

Dimensions in inches (millimeters) and are subject to change without notice.

AS85049/112

Straight RFI/EMI Shield-Sock Shrink Boot Adapter with Optional Self-Locking Coupling Nut



AS85049

B

TABLE I: Shell Size, Entry Size, Thread and Dimensions

Accessory Shell Size Code	Series I Shell Size (Ref)	Series II Shell Size (Ref)	A Thread Class 2B	B Max Diameter	Allowable Cable Entry Size
08	9	8	7/16-28 UNEF	.858 (21.79)	01
10	11	10	9/16-24 UNEF	.984 (24.99)	01-03
12	13	12	11/16-24 UNEF	1.157 (29.39)	01-05
14	15	14	13/16-20 UNEF	1.279 (32.49)	03-07
16	17	16	15/16-20 UNEF	1.406 (35.71)	05-09
18	19	18	1 1/16-18 UNEF	1.516 (38.51)	06-10
20	21	20	1 3/16-18 UNEF	1.642 (41.71)	08-12
22	23	22	1 5/16-18 UNEF	1.768 (44.91)	09-13
24	25	24	1 7/16-18 UNEF	1.889 (47.98)	10-14

TABLE II: Entry Size and Dimensions

Entry Size	W ± .020 (.51)	Y +.008 (.20) -.000 (.00)	Z Max
01	.250 (6.4)	.044 (1.12)	.560 (14.2)
02	.312 (7.9)	.044 (1.12)	.630 (16.0)
03	.375 (9.5)	.044 (1.12)	.690 (17.5)
04	.438 (11.1)	.044 (1.12)	.750 (19.1)
05	.500 (12.7)	.044 (1.12)	.820 (20.8)
06	.562 (14.3)	.044 (1.12)	.890 (22.6)
07	.625 (15.9)	.044 (1.12)	.950 (24.1)
08	.688 (17.5)	.044 (1.12)	1.020 (25.9)
09	.750 (19.1)	.069 (1.75)	1.120 (28.4)
10	.812 (20.6)	.069 (1.75)	1.200 (30.5)
11	.875 (22.2)	.069 (1.75)	1.270 (32.3)
12	.938 (23.8)	.069 (1.75)	1.260 (32.0)
13	1.000 (25.4)	.069 (1.75)	1.370 (34.8)
14	1.125 (28.6)	.069 (1.75)	1.470 (37.3)

Table III: Symbol and Finish

Symbol	Finish
N	Electroless Nickel
W	Cadmium/Olive Drab over Electroless Nickel (1000 Hour Salt Spray)
X	Nickel Fluorocarbon Polymer
Z	Zinc Nickel

Table IV: Symbol and Finish

Symbol	Finish
K	Nickel Plate
T	Tin Plate

Table V: (Manufacturer's Option)

Material	Finish
Copper	Tin Plate
Stainless Steel	Passivated

APPLICATION NOTES

- Metric equivalents are given for general information only and are based on 1.000 inch (25.40 mm).
- Dimensions are in inches and apply after plating. Accessory configuration is optional within the specified dimension envelope.
- Adapter length is measured from the bottom of the accessory teeth to the adapter that is covered by the braid. The adapter surface under the braid shall be ribbed knurled or have a surface roughness of .125 R minimum in accordance with ANSI B46.1.
- Pig tail terminated braid material shall be in accordance with Table IV. Braid length is defined by Note 1 as shown in the part or identifying number (PIN).
- Termination band configuration is not controlled. Band with buckle may exceed the "Z" dimension (See Table II) provided the band does not interfere with boot attachment, band material shall be specified as in Table V.
- Shrink boot (when required) shall be as specified in AS5258.
- Termination of the accessory shield with harness shield may be performed with a AS85049/93 shield support ring or similar split ring accessory types.
- Three (3) holes equally spaced shall be provided and accommodate .020 (.51) maximum safety wire for the non-self-locking coupling configuration.
- Drain holes will be provided with a .125 (3.2 mm) diameter, 4 places equally spaces (optional, see part number development). O-Ring not required when drain hole option is specified.
- Material/Finish:
 Adapter, coupling nut - Al alloy/See Table III
 Band - See Table V, manufacturer's option
 Braid - Copper/See Table IV

Dimensions in inches (millimeters) and are subject to change without notice.