

# AS85049/118

## Straight Strain Relief

### Self-Locking or Non-Self-Locking

#### CONNECTOR DESIGNATOR:

A

AS5015 Series AS34001 Crimp,  
MIL-DTL-26482 Series II,  
SAE-AS1703 Crimp Series III,  
MIL-DTL-83723 Series I & III

#### Material and Finish Designator

A = Aluminum, Black Anodize  
N = Aluminum, Electroless Nickel  
S = Stainless Steel, Passivate  
W = Aluminum, Cadmium, Olive Drab  
X = Aluminum, Nickel Fluorocarbon Polymer  
Y = Aluminum, Pure Dense Electrodeposited Aluminum  
Z = Aluminum, Zinc-Nickel

B

Product Series and  
Basic Part Number

M85049/118

S

08

W

S = Detented Self-Locking  
N = Non-Detented Self-Locking  
Use Dash (-) for Non-Self-Locking  
(See Note 5)

Dash No.  
Table I

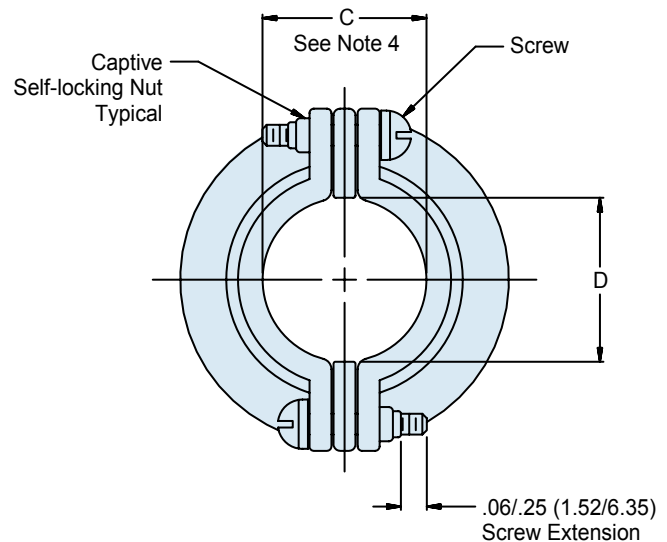
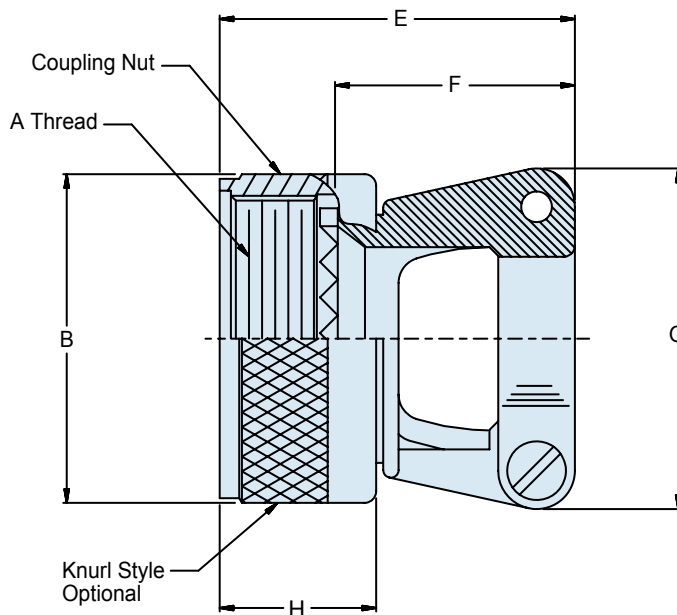

#### APPLICATION NOTES

1. Assembly to be identified with manufacturer's name and part number, space permitting.
2. Glenair Series 600 Backshell Assembly Tools are recommended for assembly and installation.
3. Metric equivalents in parentheses (mm) are given for general information only and are based on 1.000 inch = 25.4 mm.
4. Cable entry is measured with saddle bars closed and bottomed on clamp ears.
5. Detented self-locking has a positive audible detented coupling.
6. Material/Finish:  
Clamp body, coupling nut, saddles - Al alloy or 300 Series SST/See Table II.  
Clamp screws and lock nuts - CRES/Passivated, Silver plate optional.  
Anti-rotation device - Corrosion resistant material

Dimensions in inches (millimeters) and are subject to change without notice.

AS85049/118  
Straight Strain Relief  
Self-Locking or Non-Self-Locking



AS85049

B

TABLE I: Dash Number, Shell Size, Thread and Dimensions (Continued Below)

Dash No.	Screw Size	MIL-DTL-83723 Series III	MIL-DTL-5015 MS3400 Series	AS81703 Series III	MIL-DTL-26482 Series II	A Thread Class 2B	B Dia Max	C Dim ± .031 (0.8)	D Min	E Max Length
03	4-40	—	—	3	—	9/16-24 UNEF	.95 (24.1)	.219 (5.6)	.22 (5.6)	1.14 (29.0)
08	4-40	8	8S	—	8	1/2-20 UNF	.89 (22.6)	.219 (5.6)	.22 (5.6)	1.14 (29.0)
10	4-40	10	10S, 10SL	—	10	5/8-20 UNEF	1.01 (25.7)	.264 (6.7)	.27 (6.9)	1.25 (31.8)
12	4-40	12	12, 12S	7	12	3/4-20 UNEF	1.14 (29.0)	.344 (8.7)	.35 (8.9)	1.38 (35.1)
14	4-40	14	14, 14S	12	14	7/8-20 UNEF	1.26 (32.0)	.460 (11.7)	.47 (11.9)	1.38 (35.1)
16	4-40	16	16, 16S	19	16	1-20 UNEF	1.39 (35.3)	.545 (13.8)	.55 (14.0)	1.50 (38.1)
18	6-32	18	18	27	18	1 1/16-18 UNEF	1.51 (38.4)	.615 (15.6)	.62 (15.7)	1.75 (44.5)
20	6-32	20	20	37	20	1 3/16-18 UNEF	1.64 (41.7)	.698 (17.7)	.70 (17.8)	1.88 (47.8)
22	6-32	22	22	—	22	1 5/16-18 UNEF	1.176 (44.7)	.780 (19.8)	.78 (19.8)	2.00 (50.8)
24	8-32	24	24	—	—	1 7/16-18 UNEF	1.89 (48.0)	.850 (21.6)	.85 (21.6)	2.13 (54.1)
28	8-32	—	28	—	—	1 3/4-18 UNS	2.14 (54.4)	.950 (24.1)	.95 (24.1)	2.56 (65.0)
32	8-32	—	32	—	—	2-18 UNS	2.40 (61.0)	1.015 (25.8)	1.02 (25.2)	2.81 (71.4)
36	8-32	—	36	—	—	2 1/4-16 UN	2.64 (67.1)	1.187 (30.1)	1.19 (30.2)	3.06 (77.7)
40	8-32	—	40	—	—	2 1/2-16 UN	2.89 (73.4)	1.220 (31.0)	1.22 (31.0)	3.16 (80.3)
44	8-32	—	44	—	—	2 3/4-16 UN	3.14 (79.8)	1.500 (38.1)	1.50 (38.1)	3.53 (89.7)
48	8-32	—	48	—	—	3-16 UN	3.39 (86.1)	1.625 (41.3)	1.63 (41.4)	3.93 (99.8)
61	8-32	—	—	61	—	1 1/2-18 UNEF	1.95 (49.5)	.850 (21.6)	.85 (21.6)	2.13 (54.1)

TABLE I: (Continued from Above)

Dash No.	Screw Size	MIL-DTL-83723 Series III	MIL-DTL-5015 MS3400 Series	AS81703 Series III	MIL-DTL-26482 Series II	F Dim	G Dim Max	H Dim Max
03	4-40	—	—	3	—	.77 (19.6) .51 (13.0)	.88 (22.4)	.710 (18.00)
08	4-40	8	8S	—	8	.77 (19.6) .51 (13.0)	.88 (22.4)	.710 (18.00)
10	4-40	10	10S, 10SL	—	10	.89 (22.6) .64 (16.3)	.94 (23.9)	.710 (18.00)
12	4-40	12	12, 12S	7	12	1.01 (25.7) .76 (19.3)	1.12 (28.4)	.710 (18.00)
14	4-40	14	14, 14S	12	14	1.01 (25.7) .76 (19.3)	1.19 (30.3)	.710 (18.00)
16	4-40	16	16, 16S	19	16	1.13 (28.7) .88 (22.4)	1.44 (36.6)	.710 (18.00)
18	6-32	18	18	27	18	1.38 (35.1) 1.13 (28.7)	1.56 (39.6)	.710 (18.00)
20	6-32	20	20	37	20	1.51 (38.4) 1.25 (31.8)	1.69 (42.9)	.710 (18.00)
22	6-32	22	22	—	24	1.62 (41.1) 1.38 (35.1)	1.75 (44.5)	.710 (18.00)
24	8-32	24	24	—	—	1.76 (44.7) 1.51 (38.4)	1.88 (47.8)	.710 (18.00)
28	8-32	—	28	—	—	2.03 (51.6) 1.67 (42.5)	2.12 (53.8)	.890 (22.6)
32	8-32	—	32	—	—	2.28 (57.9) 1.87 (47.5)	2.50 (63.5)	.890 (22.6)
36	8-32	—	36	—	—	2.53 (64.3) 2.22 (56.4)	2.62 (66.5)	.890 (22.6)
40	8-32	—	40	—	—	2.63 (66.8) 2.41 (61.2)	2.68 (68.1)	.890 (22.6)
44	8-32	—	44	—	—	3.00 (76.2) 2.80 (71.1)	3.00 (76.2)	.890 (22.6)
48	8-32	—	48	—	—	3.40 (86.4) 3.20 (81.3)	3.50 (88.9)	.890 (22.6)
61	8-32	—	—	61	—	1.76 (44.7) 1.51 (38.5)	1.88 (47.8)	.710 (18.00)

Dimensions in inches (millimeters) and are subject to change without notice.

© 2013 Glenair, Inc.

Mil-Spec Backshells

U.S. CAGE Code 06324

Printed in U.S.A.

GLENAIR, INC. • 1211 AIR WAY • GLENDALE, CA 91201-2497 • 818-247-6000 • FAX 818-500-9912  
www.glenair.com

B-127  
Rev. 05.15.18

E-Mail: sales@glenair.com