

**Basic  
Part Number**
**Dash Number  
Table I**
**M85049/130**
**- 18**
**S**
**Material**

**C** = Conductive Silicone with Aluminum or Monel Mesh, Capable of 80 dB at 100 MHz. Temperature Range -57° to +260° C.

**F** = Fluorosilicone IAW SAE AMS-R-25988

**M** = Conductive Silver Filled Silicone IAW MIL-DTL-83528 Type B, Capable of 100 dB at 10GHz. Temperature Range -55° to +160° C.

**N** = Neoprene IAW AMS 3208.

**S** = Silicone IAW AA-59588

**V** = Viton IAW MIL-R-83248

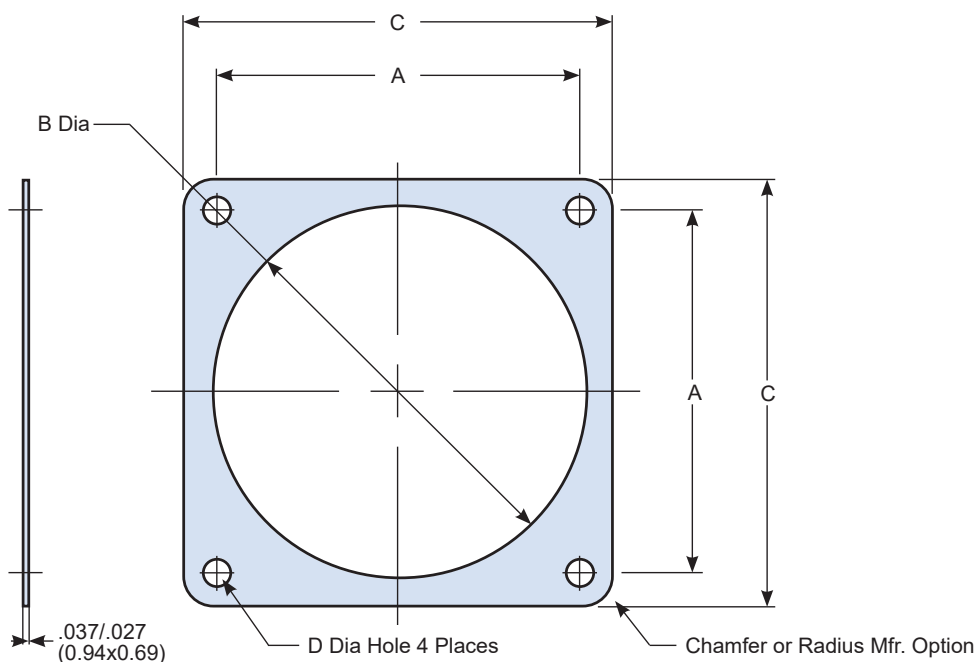
**TABLE I: Dimensions**

Dash No.	A ± .015 (0.38)	B +.020 (0.05) -.000	C ± .015 (0.38)	D ± .010 (0.25)
01	.594 (15.09)	.568 (14.43)	.812 (20.62)	.125 (3.18)
02	.594 (15.09)	.500 (12.70)	.875 (22.23)	.156 (3.96)
03	.625 (15.88)	.603 (15.32)	.896 (22.76)	.125 (3.18)
04	.719 (18.26)	.680 (12.27)	.937 (23.80)	.125 (3.18)
05	.719 (18.26)	.625 (15.88)	1.000 (25.40)	.156 (3.96)
06	.750 (19.05)	.750 (19.05)	1.023 (25.98)	.125 (3.18)
07	.812 (20.62)	.875 (22.23)	1.060 (26.92)	.141 (3.58)
08	.812 (20.62)	.828 (21.03)	1.114 (28.30)	.125 (3.18)
09	.813 (20.65)	.750 (19.05)	1.094 (27.79)	.141 (3.58)
10	.843 (21.41)	.875 (22.23)	1.138 (28.91)	.125 (3.58)
11	.906 (23.01)	1.005 (25.53)	1.153 (29.29)	.125 (3.58)
12	.906 (23.01)	.938 (23.83)	1.125 (28.58)	.125 (3.58)
13	.906 (23.01)	.875 (22.23)	1.188 (30.18)	.156 (3.96)
14	.969 (24.61)	1.135 (28.83)	1.258 (31.95)	.156 (3.96)
15	.969 (24.61)	1.063 (27.00)	1.250 (31.75)	.125 (3.58)

Continued on Page B-141

Dimensions in inches (millimeters) and are subject to change without notice.

**TABLE I: Dimensions  
(Continued From Page B-140)**

Dash No.	A ± .015 (0.38)	B +.020 (0.05) -.000	C ± .015 (0.38)	D ± .010 (0.25)
16	.969 (24.61)	1.000 (25.4)	1.281 (32.54)	.156 (3.69)
17	1.015 (25.78)	1.125 (28.58)	1.383 (35.13)	.125 (3.18)
18	1.062 (26.97)	1.260 (32.00)	1.351 (34.32)	.156 (3.96)
19	1.062 (26.97)	1.189 (30.20)	1.343 (34.11)	.125 (3.18)
20	1.062 (26.97)	1.135 (28.83)	1.375 (34.92)	.156 (3.96)
21	1.140 (28.96)	1.312 (33.32)	1.508 (38.30)	.125 (3.18)
22	1.156 (29.36)	1.375 (34.92)	1.500 (38.10)	.141 (3.58)
23	1.156 (29.36)	1.312 (33.32)	1.467 (37.26)	.125 (3.18)
24	1.156 (29.36)	1.250 (31.75)	1.500 (38.10)	.177 (4.50)
25	1.187 (30.15)	1.266 (32.16)	1.458 (37.03)	.125 (3.58)
26	1.250 (31.75)	1.500 (38.10)	1.625 (41.28)	.141 (3.58)
27	1.250 (31.75)	1.437 (36.50)	1.562 (39.67)	.125 (3.58)
28	1.250 (31.75)	1.375 (34.92)	1.625 (41.28)	.177 (4.50)
29	1.281 (32.54)	1.500 (38.10)	1.718 (43.64)	.125 (3.18)
30	1.375 (34.92)	1.625 (41.28)	1.750 (44.45)	.177 (3.18)
31	1.375 (34.92)	1.563 (39.70)	1.703 (43.26)	.156 (3.96)
32	1.375 (34.92)	1.500 (38.10)	1.750 (44.45)	.203 (5.16)
33	1.392 (35.36)	1.625 (41.28)	1.818 (46.18)	.141 (3.58)
34	1.436 (36.47)	1.570 (39.88)	1.799 (45.69)	.125 (3.18)
35	1.500 (38.10)	1.750 (44.45)	1.875 (47.63)	.177 (3.18)
36	1.562 (39.67)	1.750 (44.45)	2.000 (50.80)	.203 (5.16)
37	1.568 (39.83)	1.875 (47.63)	2.138 (54.31)	.141 (3.58)
38	1.719 (43.66)	2.000 (50.80)	2.375 (60.33)	.177 (3.18)
39	1.734 (44.04)	2.062 (52.37)	2.328 (59.13)	.177 (3.18)
40	1.750 (44.45)	2.000 (50.80)	2.250 (57.15)	.219 (5.56)
41	1.906 (48.41)	2.250 (57.15)	2.625 (66.68)	.219 (5.56)
42	1.938 (49.23)	2.250 (57.15)	2.500 (63.50)	.219 (5.56)
43	2.188 (55.58)	2.500 (63.50)	2.750 (69.85)	.219 (5.56)
44	2.375 (60.33)	2.781 (70.64)	3.000 (76.20)	.219 (5.56)
45	2.406 (61.11)	2.750 (69.85)	3.125 (79.38)	.281 (7.14)
46	2.625 (66.68)	3.031 (76.99)	3.250 (82.55)	.219 (5.56)
47	2.656 (67.46)	3.000 (76.20)	3.375 (85.73)	.281 (7.14)
48	2.906 (73.81)	3.250 (82.55)	3.625 (92.08)	.281 (7.14)
49	3.156 (80.16)	3.500 (88.90)	3.875 (98.43)	.281 (7.14)

**APPLICATION NOTES**

1. Assembly identified with manufacturer's name and part number, space permitting.
2. For complete dimensions, see the applicable Military Specification.
3. Metric dimensions (mm) are in parentheses.

Dimensions in inches (millimeters) and are subject to change without notice.