



SERIES 927-072
ITS-Ex Hazardous Zone Connectors
Cable plug with basket weave cable grip



927-072-036 CABLE PLUG WITH ENVIRONMENTAL CABLE ADAPTER AND BASKET WEAVE CABLE GRIP

How To Order							
Sample Part Number	927-072	036	36-66	P1	F9	N	A
Series	927-072						
Style	036 = Basket Weave Cable Grip						
Shell Size - Insert Arrangement	See pages 69 – 74						
Contact Type and Plating	P = Pin Contact S = Socket Contact 1 = Silver Plated 2 = Gold Plated						
Shell Material and Finish	F9 = Aluminium Alloy, Anodize Hardcoat						
Alternate Key Position	N = Normal, X, Y, Z, W (See Table on page 75)						
Cable Range	A, B, C (See Table next page)						

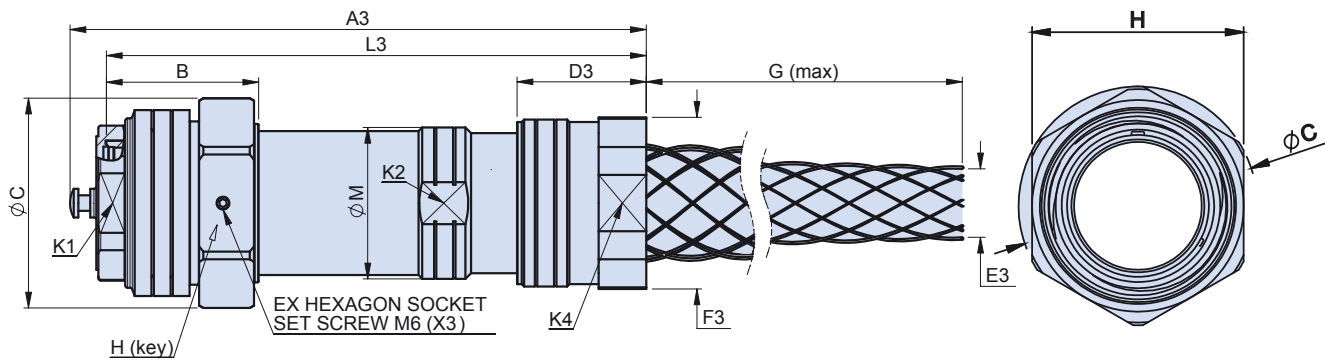

Shell Size	Dimensions													
	A3	B	C	D3	E3		F3	G Max.	H	K1	K2	K4	L3	M
					Min.	Max.								
10SL		2.20 (56.0)	1.81 (46)						1.61 (41)	0.94 (24)	0.87 (22)			0.98 (25)
18	7.17 (182)	2.52 (63.9)	2.32 (59)	1.68 (42.7)	0.50 (12.70)	0.94 (23.80)	1.81 (46.0)	201**	2.05 (52)	1.34 (34)	1.42 (36)	1.65 (42)	6.97 (177)	1.50 (38.2)
36	9.53 (242)	2.52 (63.9)	3.46 (88)	2.06 (52.4)	1.01 (25.60)	1.62 (41.25)	2.83 (72.0)	315**	3.07 (78)	2.36 (60)	2.40 (61)	2.68 (68)	8.94 (227)	2.50 (63.5)

(**) Max overall dimension; dimension less than max one, depending on Basket Weave Cable Range.

TOPSIDE: ITS-EX™



SERIES 927-072

ITS-Ex Hazardous Zone Connectors



Cable plug with basket weave cable grip

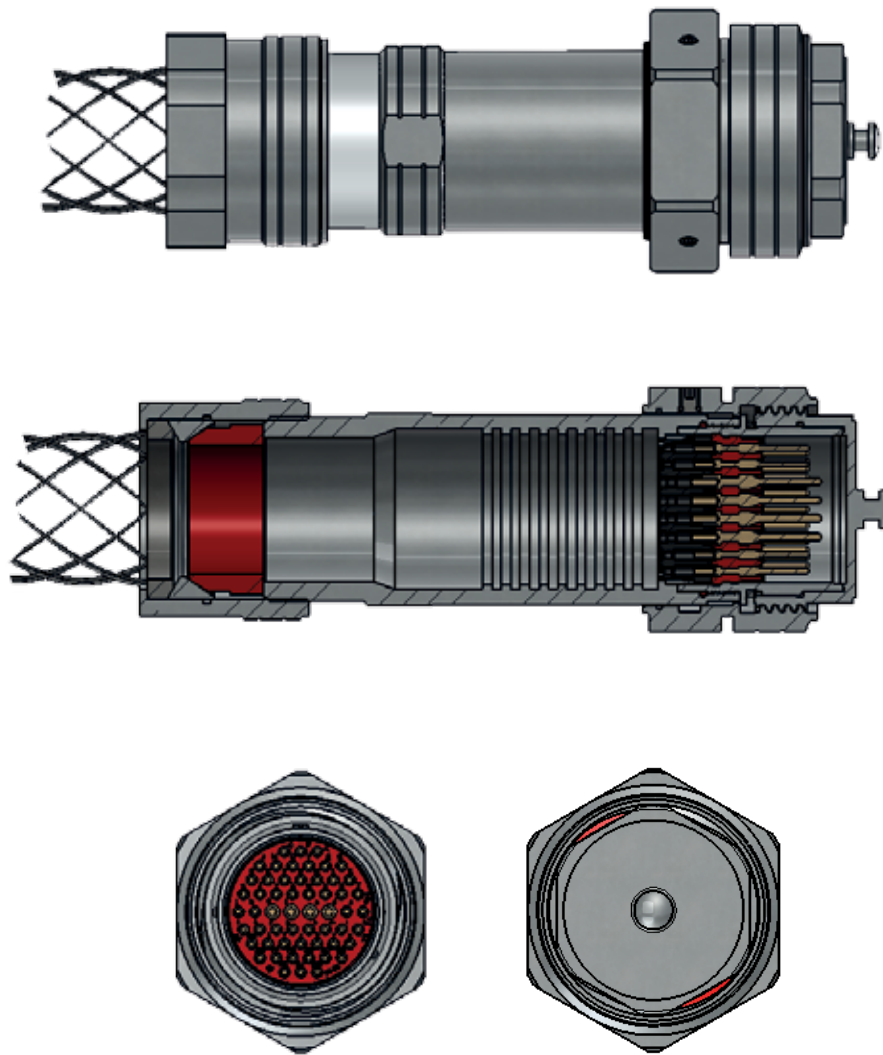

Cable Range Dimensions for Basketweave Cable Grip			
Shell Size	Cable Range Designator	Cable Type	Cable Jacket Range [mm] (1)
36	A	Unarmored cable	39,40 to 41,25
	B	Unarmored cable	38,90 to 40,50
	C	Unarmored cable	34,50 to 38,50
	D	Unarmored cable	31,00 to 34,90
	E	Unarmored cable	29,40 to 33,30
	F	Unarmored cable	25,60 to 29,50 (1)
18	A	Unarmored cable	19,60 to 23,80
	B	Unarmored cable	18,00 to 22,20 (1)
	C	Unarmored cable	15,50 to 19,10
	D	Unarmored cable	12,70 to 15,87
	E	Unarmored cable	10,40 to 12,70 (1)
10SL	Not available		

(1) It is advisable to use reduction sleeves for lower values of cable diameter within cable range.

