

ALUMINUM TOOL FOR USE WITH GLENAIR COMPOSITE BACKSHELLS

600 - 091 - 16

Product Series
Basic Number
Dash Number for Individual Wrench or:
K - Kit of dash numbers 08 thru 28
KC - "K" kit with case
KL - Kit of dash number 32 thru 44
KLC - "KL" kit with case
KIT - Kit of dash numbers 08 thru 44 with case

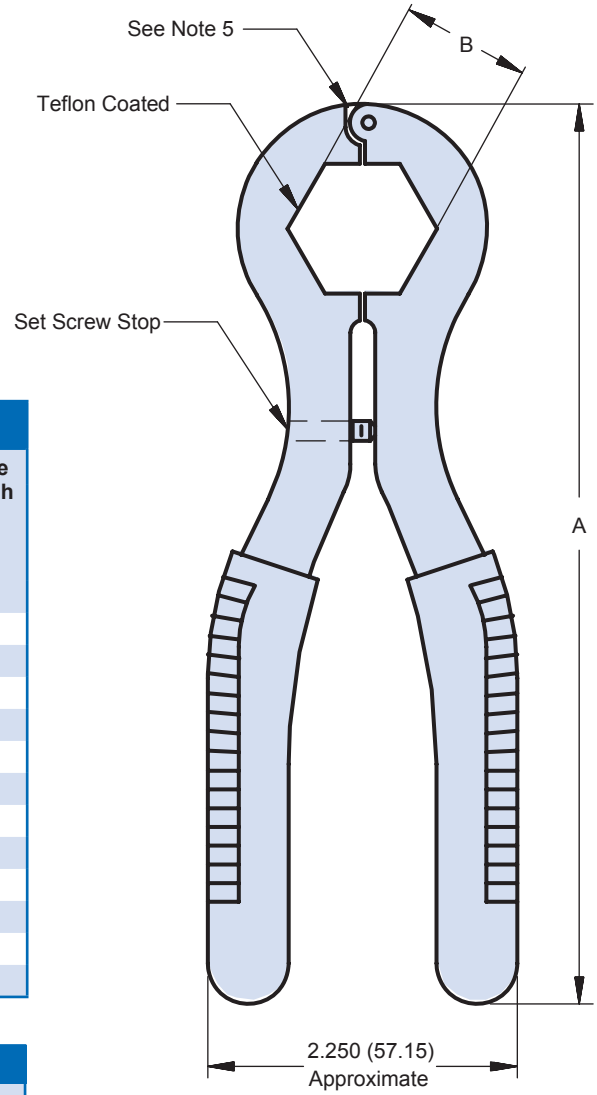
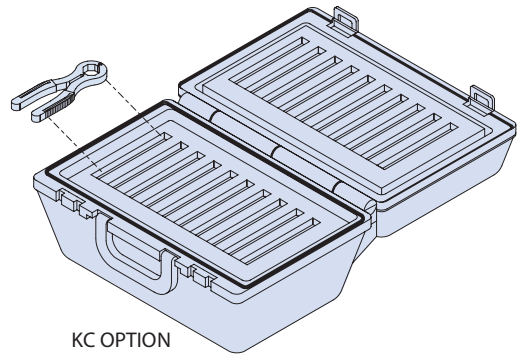

TABLE I: DASH NUMBER

Dash Number	A Ref	B Hex ² Ref	Connector for Shell Size		Composite Torque Inch Pounds In-Lbs Min/Max
			Codes A & F	Code H	
08	7.56 (192.0)	.750 (19.1)	08	09	20/25
10	7.56 (192.0)	.875 (22.2)	10	11	20/30
12	7.56 (192.0)	1.000 (25.4)	12	13	25/35
14	7.56 (192.0)	1.125 (28.6)	14	15	25/35
16	7.56 (192.0)	1.250 (31.8)	16	17	30/40
18	7.56 (192.0)	1.375 (34.9)	18	19	30/40
20	8.50 (215.9)	1.500 (38.1)	20	21	35/45
22	8.50 (215.9)	1.625 (41.3)	22	23	35/45
24	8.50 (215.9)	1.750 (44.5)	24	25	35/45
28	9.50 (241.3)	2.000 (50.8)	28		115/125
32	10.00 (254.0)	2.250 (57.2)	32		115/125
36	10.00 (254.0)	2.500 (63.5)	36		112/125
44	10.00 (254.0)	3.000 (76.2)	44		N/A

- APPLICATION NOTES**
- Use in conjunction with Glenair 600-161 torque wrench and 600-162B or 600-162BV bench mounts (see page 14).
 - Adjust set screw per tool setting procedure GAP134 (available on Glenair.com). Once adjusted must fit Glenair hex composite coupling nuts
 - Customer is responsible for maintaining adjustment to compensate for wear.
 - Replace tool if excessive wear is observed
 - Gap is permissible during tool use for coupling nut assembly
 - If set screw becomes loose causing loss of adjustment reapply suitable thread locking compound
 - Wrenches are made of aluminum alloy with vinyl grips.
 - Using other manufacturer's hex wrench pliers or soft jaw coated pliers will result in premature fracturing or damage to the composite product



KC OPTION
Approximate Case Dimensions: 13.5 x 15.5 x 3.875