

## 189-043 MIL-PRF-M28876 Style Banding Insert Retention Nut

HOW TO ORDER			
Sample Part Number	189-043	-15	M
Basic Number	MIL-PRF-M28876 Style Banding Insert Retention Nut		
Shell Size	See Material/Finish table		
Material/Finish Code	<b>M</b> = Electroless nickel <b>ZR</b> = Zinc-nickel, black Omit for standard finish per notes		

### MATERIAL AND FINISH

- Al alloy/see How to Order table
- Finish: cadmium, olive drab over electroless nickel

### NOTES

- Product identified with manufacturer's name, cage code, part number, and date code.
- Banding strap to be ordered separately as follows:
  - 600-052 = band, flat
  - 600-052-1 = band, pre-coiled

### DIMENSIONS

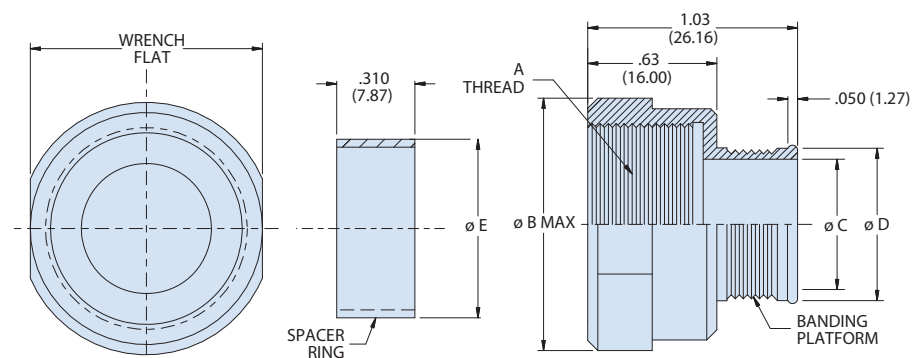

Shell Size	Shell Size Designator (Ref)	A Thread Class 2B	$\phi B \text{ Max}$	$\phi C$	$\phi D$	$\phi E$
11	A	.7500-20 UNEF	1.010 (25.65)	.350 (8.89)	.410 (10.41)	.410 (10.41)
13	B	.8750-20 UNEF	1.135 (28.83)	.460 (11.68)	.520 (13.21)	.532 (13.51)
15	C	1.0000-20 UNEF	1.260 (32.00)	.645 (16.38)	.705 (17.91)	.710 (18.03)
23	F	1.4375-18 UNEF	1.698 (43.13)	1.045 (26.54)	1.105 (28.07)	1.116 (28.35)

MATERIAL AND FINISHES (COMMERCIAL 180-040 SERIES)		
Code	Material	Finish Description
GB4	Aluminum Alloy	Hard Anodize, Black with PTFE
ME		Electroless Nickel
MT		Nickel-PTFE, Grey
NF		Cadmium, Olive Drab
TZ		Tin-Zinc, Bronze-Gold
ZR		Zinc-Nickel, Black